

# FANUC AC SERVO UNIT

## MAINTENANCE MANUAL

VIC 6 6050-1110/1

CONTENTS

I. AC SERVO UNIT FOR 1 AXIS .....	1
1. STRUCTURE .....	3
1.1 Models and Designated Specifications of Units .....	4
2. CONNECTIONS .....	6
2.1 Connection Diagram .....	6
2.2 Detailed Servo System Connection Diagrams .....	8
2.2.1 Details of connections of cable K1 .....	8
2.2.2 Details of connections of cable K2 .....	9
2.2.3 Details of connections of cable K3 .....	9
2.2.4 Details of connections of cable K4 .....	10
2.2.5 Details of connections of cable K5 .....	10
2.2.6 Details of connections of cable K6 .....	12
2.2.7 Details of connections of cable K7 .....	15
2.2.8 Connections of separate regenerative discharge unit .....	16
2.3 Connection of Power Supply Transformer Tap .....	18
2.3.1 Primary side connection .....	18
2.3.2 Connections in the power supply transformer .....	20
2.3.3 Motors and power transformers employed for each axis .....	23
2.4 Connection Diagram of Velocity Control Unit .....	24
2.4.1 For Model 2-0, 1-0 (A06B-6050-H002) .....	24
2.4.2 For Model 0, 5 (A06B-6050-H102) .....	25
2.4.3 For Model 10, 20M, 20, 30 (A06B-6050-H103, H113, H104) .....	26
2.4.4 In case Model 30R (A06B-6050-H005) .....	27
2.4.5 For Model 0 - 30 (A06B-6050-H003, H004) .....	28
3. SETTING AND ADJUSTMENT FOR VELOCITY CONTROL UNIT .....	29
3.1 Setting and Adjustment for Velocity Control PCB .....	29
3.1.1 Parts location .....	29
3.1.2 Setting terminal .....	38
3.1.3 Variable resistor .....	45
3.1.4 Check terminals .....	46
3.2 Block Diagram of Velocity Control Unit .....	48
4. TROUBLESHOOTING .....	49
4.1 Protection and Fault Detecting Functions .....	49
4.2 Troubleshooting .....	50
5. PARTS SPECIFICATIONS AND LOCATIONS ON VELOCITY UNIT .....	56
5.1 Model 5-0 Velocity Control Unit (A06B-6050-H301) .....	56
5.2 Model 4-0, 3-0 Velocity Control Unit (A06B-6050-H001) .....	57
5.3 Model 2-0, 1-0, Velocity Unit (A06B-6050-H002) .....	58
5.4 Model 0, 5 Velocity Unit (A06B-6050-H102) .....	59
5.5 Model 10 Velocity Unit (A06B-6050-H103) .....	60
5.6 Model 20M Velocity Unit (A06B-6050-H113) .....	61
5.7 Model 20, 30 Velocity Unit (A06B-6050-H104) .....	62
5.8 Model 30R Velocity Unit (A06B-6050-H0050) .....	63
5.9 Model 0, 5, 10 Velocity Unit (A06B-6050-M003) .....	64
5.10 Model 20, 30 Velocity Unit (A06B-6050-H004) .....	65
II. AC SERVO UNIT FOR 2 AXES .....	67
1. STRUCTURE .....	69
1.1 Types of Units and Designated Specifications .....	70

2.	CONNECTIONS .....	80
2.1	Connection Diagram .....	80
2.2	Detailed Servo System Connection Diagram .....	80
2.2.1	Details of connections of cable K1 .....	82
2.2.2	Details of connections of cable K2 .....	82
2.2.3	Details of connections of cable K3 .....	83
2.2.4	Details of connections of cable K4 .....	84
2.2.5	Details of connections of cable K5 .....	84
2.2.6	Details of connections of cable K6 .....	85
2.2.7	Details of connections of cable K7 .....	85
2.3	Connection of Power Transformer .....	86
2.4	Connection Diagram of Velocity Control Unit .....	86
3.	SETTING AND ADJUSTMENT OF VELOCITY CONTROL UNIT .....	86
3.1	Setting and Adjustment of Velocity Control Unit PCB .....	86
3.1.1	Parts location .....	86
3.1.2	Setting terminal .....	87
3.1.3	Variable resistor .....	87
3.1.4	Check terminals .....	88
3.2	Block Diagram of Velocity Control Unit .....	88
4.	TROUBLESHOOTING .....	88
4.1	Protection and Fault Detect Function .....	88
4.2	Troubleshooting .....	88
5.	PARTS SPECIFICATION AND LOCATIONS ON VELOCITY UNIT .....	88
5.1	Model 1-0/2-0 and Model 1-0/2-0 (A06B-6050-H201) .....	88
5.2	Model 1-0/2-0 and Model 0/5 (A06B-6050-H202) .....	89
5.3	Model 0/5 and Model 0/5 (A06B-6050-H203) .....	89
III.	AC SERVO UNIT FOR 3 AXES .....	91
1.	STRUCTURE .....	93
1.1	Types of Unit and Specification Number .....	94
2.	CONNECTIONS .....	96
2.1	Connection Diagram .....	96
2.2	Detailed Servo System Connection Diagram .....	99
2.2.1	Details of connections of cable K1 .....	99
2.2.2	Details of connections of cable K2 .....	100
2.2.3	Details of connections of cable K3 .....	100
2.2.4	Details of connections of cable K4 .....	100
2.2.5	Details of connections of cable K5 .....	101
2.2.6	Details of connections of cable K6 .....	102
2.2.7	Details of connections of cable K7 .....	103
2.2.8	Connections of separate discharge unit .....	104
2.3	Connection of Power Transformer .....	107
2.4	Connection Diagram of Velocity Control Unit .....	108
2.4.1	Model 0/5, Model 0/5 and Model 0/5 (A06B-6050-H401) .....	108
2.4.2	Model 0/5, Model 0/5 and Model 10 (A06B-6050-H402) .....	109
2.4.3	Model 0/5, Model 10 and Model 10 (A06B-6050-H403) .....	110
2.4.4	Model 10, Model 10 and Model 10 (A06B-6050-H404) .....	111
3.	SETTING AND ADJUSTMENT OF VELOCITY CONTROL UNIT .....	113
3.1	Setting and Adjustment of Velocity Control Unit PCB .....	113
3.1.1	Parts location .....	113
3.1.2	Setting terminal .....	114

3.1.3	Variable resistor .....	115
3.1.4	Check terminals .....	116
3.2	Block Diagram of Velocity Control Unit .....	117
4.	TROUBLESHOOTING .....	119
4.1	Protection and Fault Detecting Function .....	119
4.2	Troubleshooting .....	119
5.	PARTS SPECIFICATION AND LOCATIONS ON VELOCITY UNIT .....	120
5.1	Model 0/5, Model 0/5 and Model 0/5 (A06B-6050-H401) .....	120
5.2	Model 0/5, Model 0/5 and Model 10 (A06B-6050-H402) .....	121
5.3	Model 0/5, Model 10 and Model 10 (A06B-6050-H403) .....	122
5.4	Model 10, Model 10 and Model 10 (A06B-6050-H404) .....	123
APPENDIX	.....	125
APPENDIX 1	.....	127
1.	REVERSE CONNECTION .....	127
1.1	Connection and Rotational Direction .....	127
1.2	Method .....	127
APPENDIX 2	.....	131
1.	AC SERVO MOTOR MAINTENANCE .....	131
1.1	Outline .....	131
1.2	Acceptance and Storage .....	131
1.3	Mounting .....	131
1.4	Replacement of Pulse Coder .....	133
2.	COMPENSATING CIRCUIT SETTING FOR AC SEVO UNIT .....	135

## I. AC SERVO UNIT FOR 1 AXIS

This chapter described the maintenance of AC servo unit for 1 axis which drives AC servo motor Model 5-0, 4-0, 3-0, 2-0, 1-0, 0, 5, 10, 20M, 20, 30 and 30R.

## 1. STRUCTURE

The AC servo unit consists basically of the velocity control unit and power transformer. In addition, the separate regenerative discharge unit may be required according to the load conditions.

Eight types of velocity control units are available according to AC servo motor models employed, and one velocity control unit applies to each servo motor. Six types of power transformers are also prepared according to the servo motor models, their combinations, loads, and primary input voltages. One power transformer applies to one to three servo motors.

Fig. 1.1 shows an example of the structure of the AC servo unit in a two-controlled axes NC system.

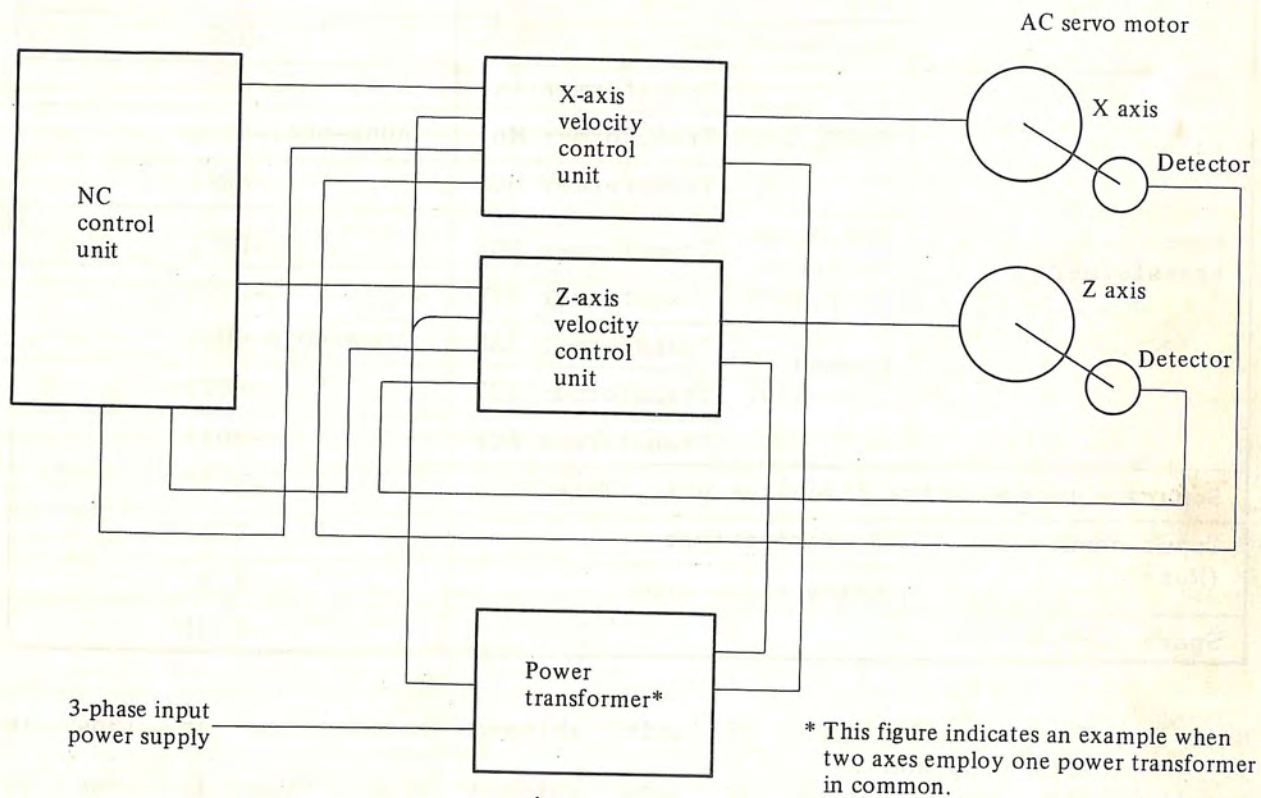

Fig. 1.1 Example of AC Servo Unit Structure

## 1.1 Models and Designated Specifications of Units

Table 1.1 (a)

Name		Specifications	
Velocity control unit	For Model 5-0	A06B-6050-H301	
	For Model 4-0, 3-0	" -H001	
	For Model 2-0, 1-0	" -H102 (Note 1)	
	For Model 0, 5, 10	" -H103 (Note 2)	
	For Model 20M	" -H113	
	For Model 20, 30	" -H104 (Note 3)	
	For Model 30R	" -H005	
Power transformer	For Japan 200V, 220V	Transformer AA	A06B-6050-H011
		Transformer MB	A06B-6047-H012
		Transformer MC	" -H013
	For other countries 190V-550V	Transformer MBE	" -H022
		Transformer MCE	" -H023
	Common 190V-550V	Transformer AAE	A06B-6050-H021
		Transformer ABE	" -H022
		Transformer ACE	" -H023
	Separate regenerative discharge unit (Note 4)		" -H050
Input connector (Note 5)	Soldering type	" -K100	
	Crimp style type	" -K103	
Spare part A		" -K101	

Note 1. The specification of unit shipped before May in 1984 is A06B-6050-H003.

Note 2. The specification of unit shipped before May in 1984 is A06B-6050-H003.

Note 3. The specification of unit shipped before May in 1984 is A06B-6050-H004.

Note 4. The unit (A06B-6050-H005) for Model 30R normally needs the separate regenerative discharge unit.

Note 5. The input connector is used for the cable connected to the velocity control unit, and it comprises the following parts.

One set of the input connector is required for each axis. Table 1.1(b) shows the parts included in input connector (Soldering type).

Table 1.1(c) shows the parts included in input connector (Crimp style type).

Table 1.1 (b) The Parts Included in Input Connector (Soldering Type)

Name	Q'ty	Use	Model	FANUC specifications
Connector and cover	1	CN1	MR-20LFH*	A63L-0001-0134/02
Connector and cover	1	CN5	MR-20LWMH*	A63L-0001-0134/15
Connector and cover	1	CN6	MR-20LWFH*	A63L-0001-0134/05
Housing	1	CN2	SMS6PW-5**	A63L-0001-0202/6W
Pin	5	CN2	RC16M-SCT3**	A63L-0001-0226

Table 1.1 (c) The Parts Included in Input Connector (Crimp Style Type)

Name	Q'ty	Use	Model	FANUC specifications
Connector and cover	1	CN1	MR-20L, MRP-20F01*	A63L-0001-0134/22
Connector and cover	1	CN5	MR-20LW, MRP-20M01*	A63L-0001-0134/35
Connector and cover	1	CN6	MR-20LW, MRP-20F01*	A63L-0001-0134/25
Contact	40	CN1,6	MRP-F112*	A63L-0001-0135/F112
Contact	20	CN5	MRP-M112*	A63L-0001-0135/M112
Housing	1	CN2	SMS6PW-5**	A63L-0001-0202/6W
Pin	5	CN2	RC16M-S23A**	A63L-0001-0127/S23A

\* Manufacturer: HONDA Tsushin Co., Ltd.

\*\* Manufacturer: Burndy Japan Co., Ltd.



## 2. CONNECTIONS

### 2.1 Connection Diagram

Fig. 2.1(a) is a standard connection diagram.

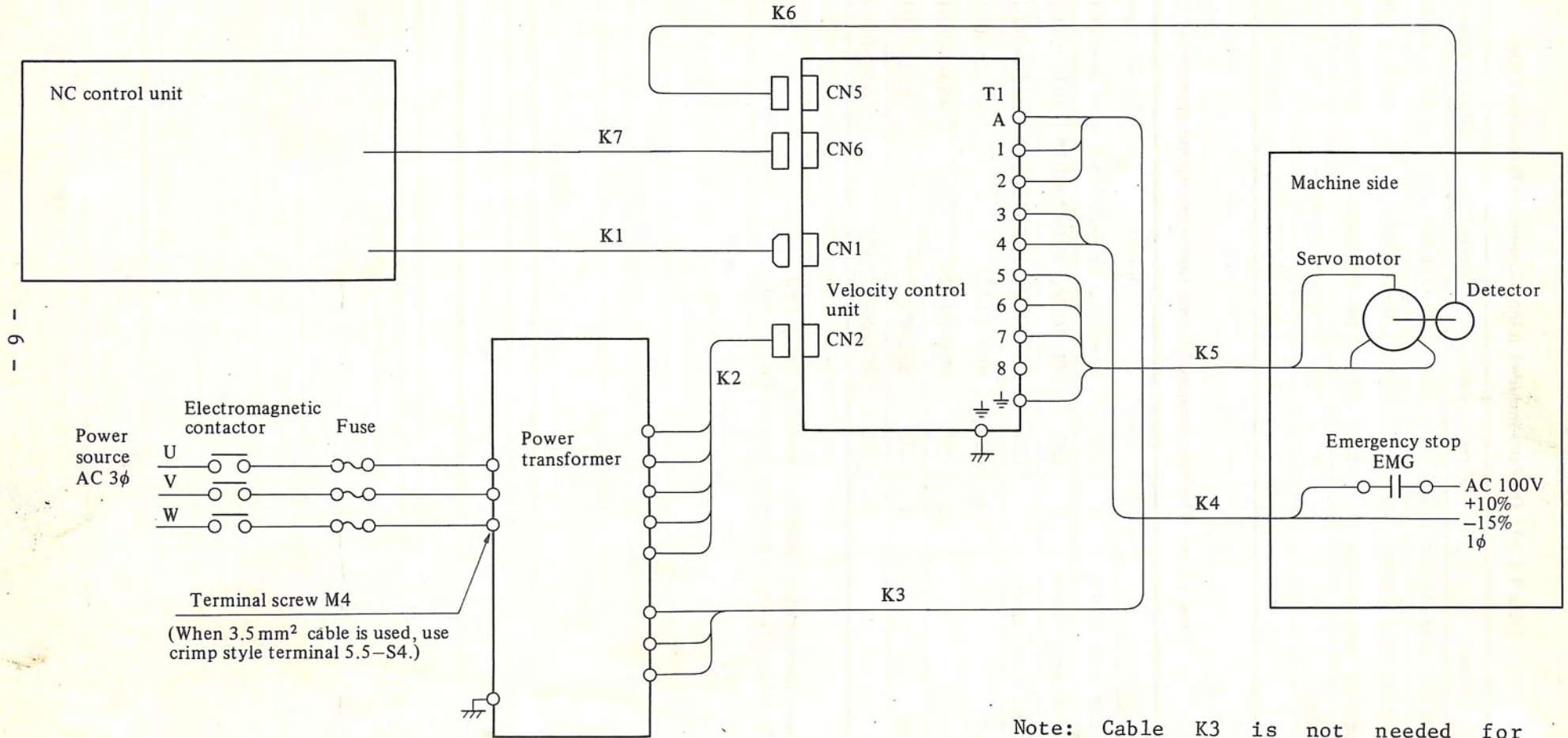

Note: Cable K3 is not needed for velocity control unit of 5-0.

Fig. 2.1 (a)

Fig. 2.1(b) shows connection diagram when the separate regenerative discharge unit is employed.

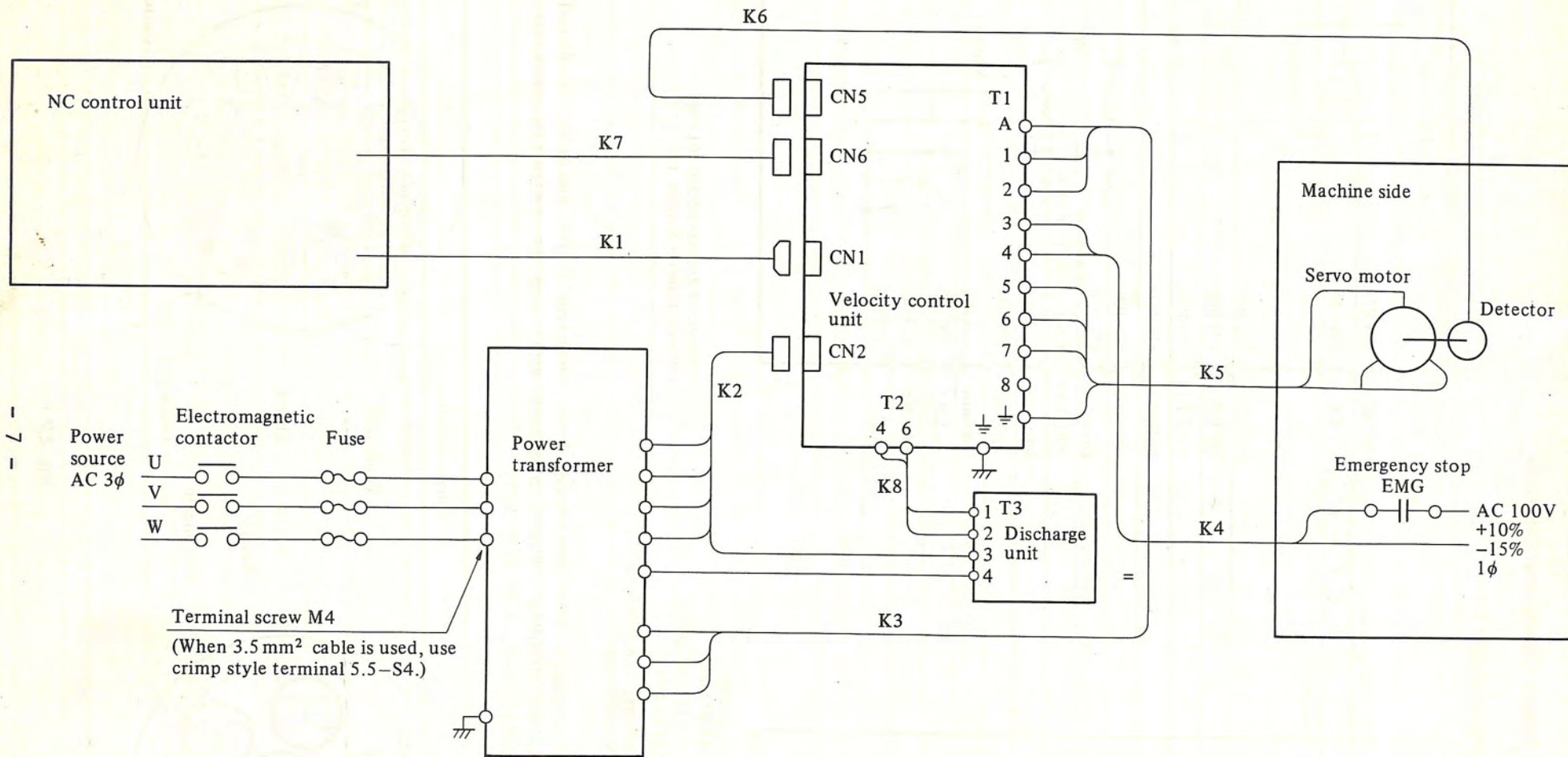
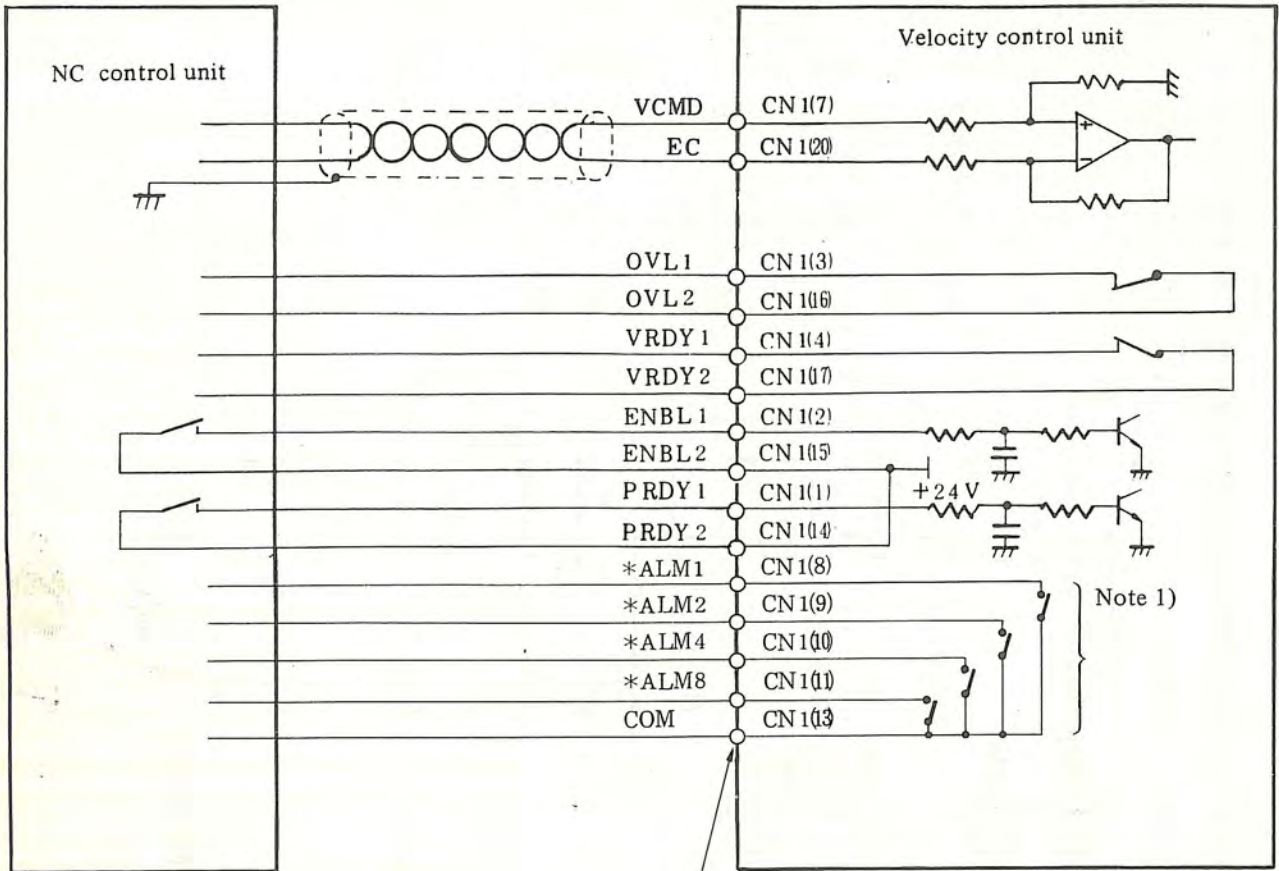

Fig. 2.1 (b)

## 2.2 Detailed Servo System Connection Diagrams

### 2.2.1 Details of connections of cable K1



Cable employed:  
 For VCMD/EC,  
 0.1 ~ 0.18mm<sup>2</sup> pair  
 shielded cable.  
 For others; 0.18 ~ 0.3mm<sup>2</sup>  
 200V vinyl wire

Connector employed MR20LFH  
 (Honda Tsushin Kogyo, Co. Ltd.)

Note: These signals are employed from edition c of velocity control PCB (A20B-1000-0560). These are not employed in velocity control unit for Model 5-0, 4-0 and 3-0.

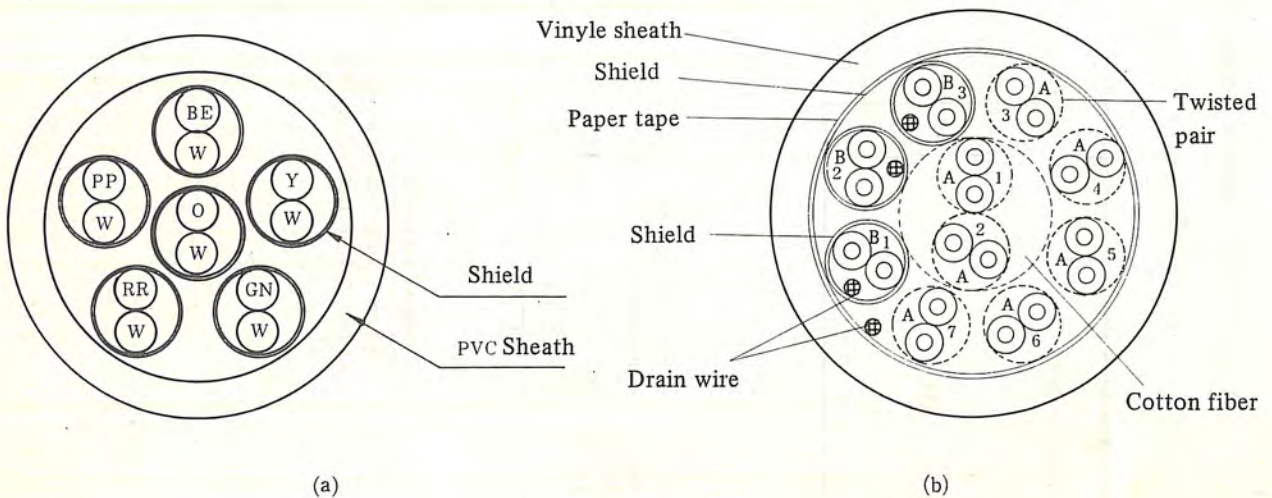

Fig. 2.2.1

### 2.2.2 Details of connections of cable K2

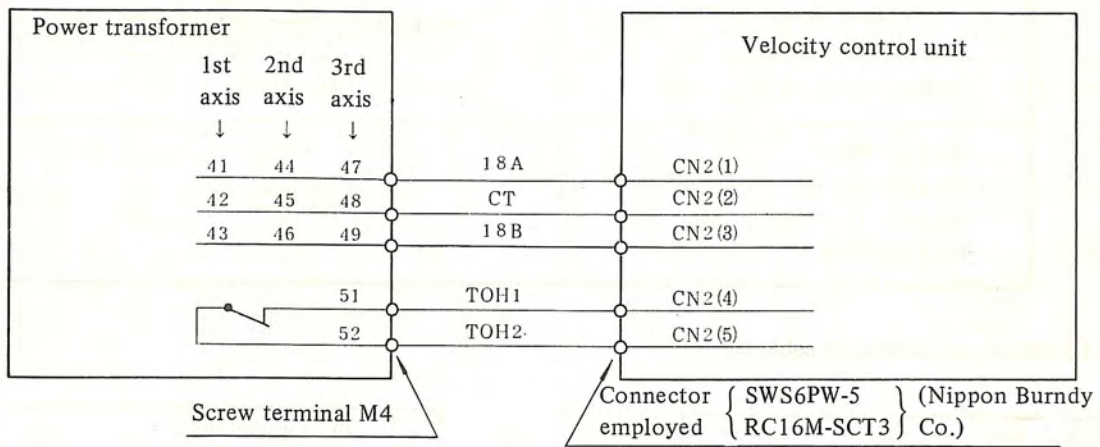
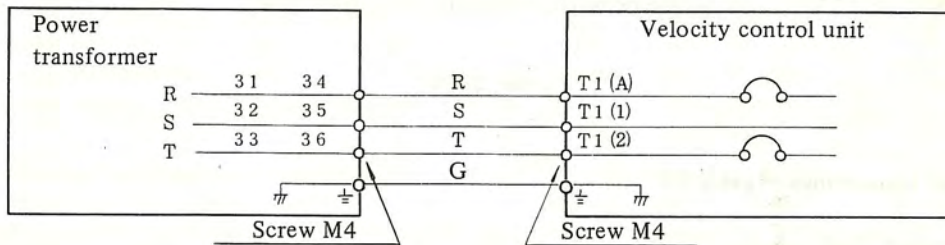

Fig. 2.2.2

### 2.2.3 Details of connections of cable K3



Cable employed: 0.75 mm<sup>2</sup> (30/0.18) 200V heat-resistive vinyl cable.

Fig. 2.2.3

Table 2.2.3 (a)

Motor employed	Cable employed	
Model 3-0, 4-0	0.75 mm <sup>2</sup>	600V heat-resistive vinyl cable
Model 2-0, 1-0 Model 0, 5	2.0 mm <sup>2</sup>	
Model 10, 20M, 20, 30	3.5 mm <sup>2</sup>	
Model 30R	5.5 mm <sup>2</sup>	

Table 2.2.3 (b)

Motor employed	Input voltage of velocity control unit
Model 4-0, 2-0, 1-0	AC 120V
Model 3-0 Model 0, 5 Model 10, 20M, 20, 30 Model 30R	AC 185V

2.2.4 Details of connections of cable K4

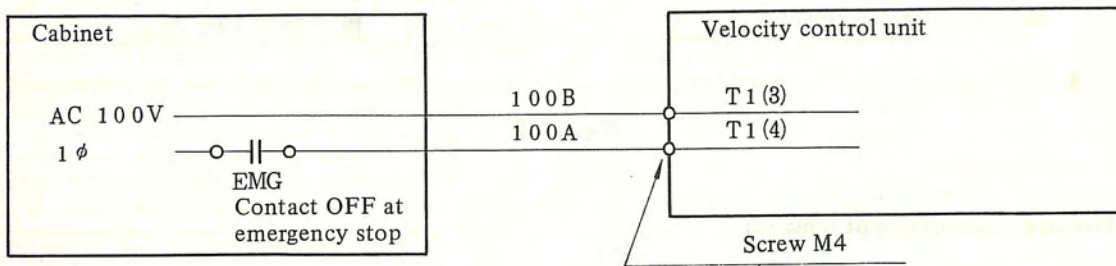

Cable material: 0.75mm<sup>2</sup> 200V vinyl wire.

Fig. 2.2.4

2.2.5 Details of connections of cable K5

(1) For Model 5-0, 4-0, 3-0

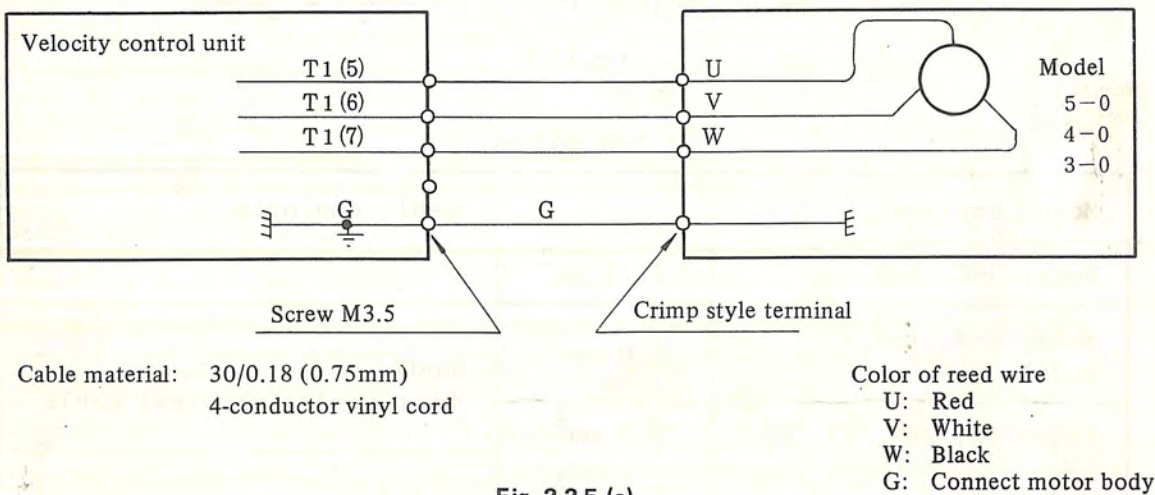
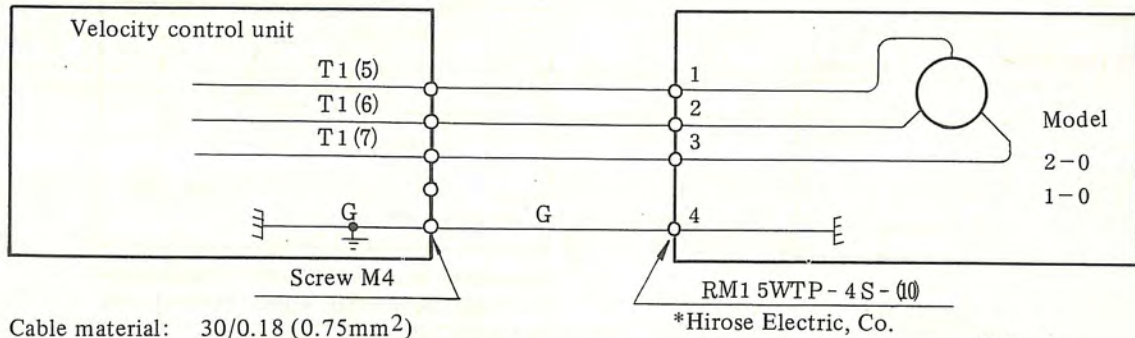

Fig. 2.2.5 (a)

(2) For Model 2-0, 1-0



Cable material: 30/0.18 (0.75mm<sup>2</sup>)  
4-conductor vinyl cabtyre cable

Fig. 2.2.5 (b)

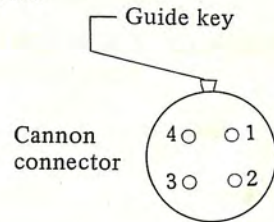

(3) For Model 0 and 5

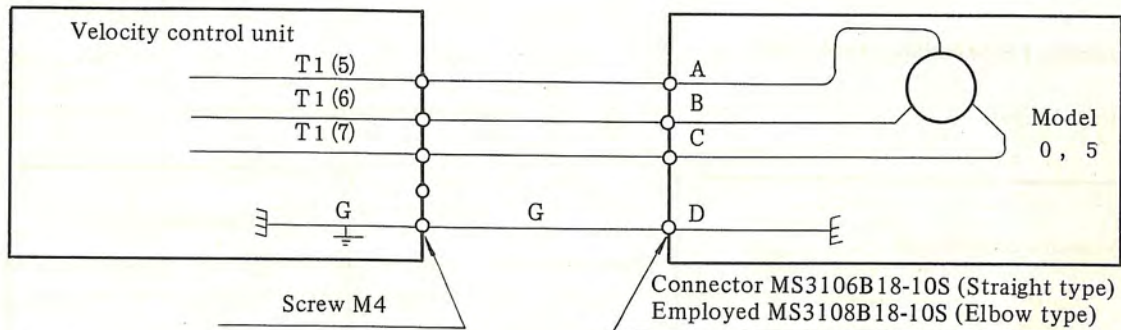

Cable material: 2.0mm<sup>2</sup> (37/0.26)  
4-conductor vinyl cabtyre cable

Fig. 2.2.5 (c)

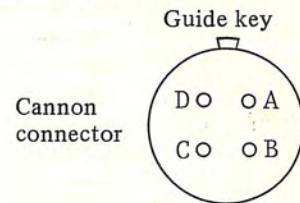

(4) For Model 10, 20M, 20, 30

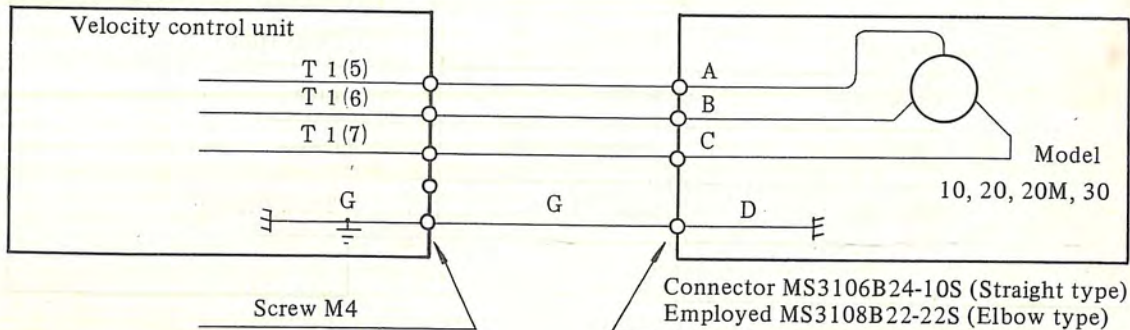

Cable material: 3.5mm<sup>2</sup> (45/0.32)  
4-conductor vinyl cable

Fig. 2.2.5 (d)

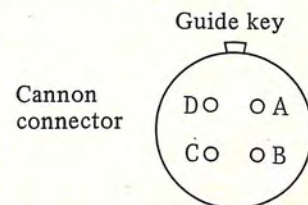

(5) For Model 30R

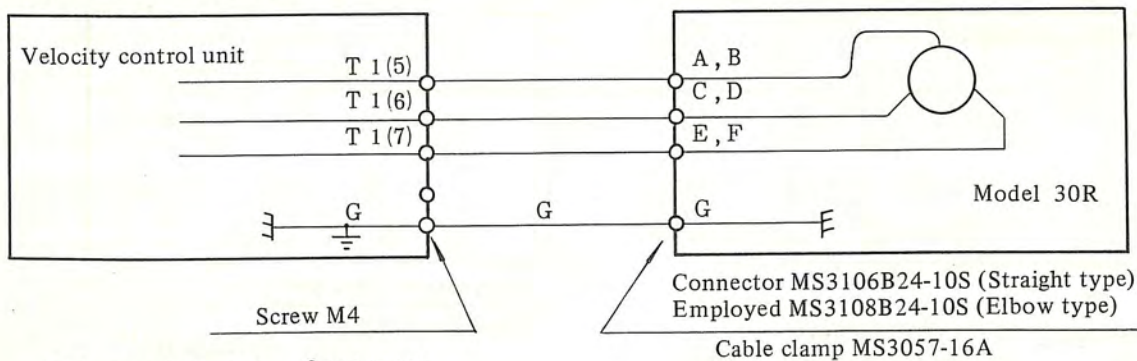

Cable material: 5.5mm<sup>2</sup> (70/0.32)  
4-conductor vinyl cabtyre cable

Guide key

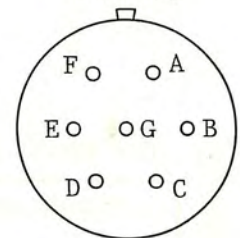

Cannon connector

Fig. 2.2.5 (e)

### 2.2.6 Details of connections of cable K6

(1) Model 5-0

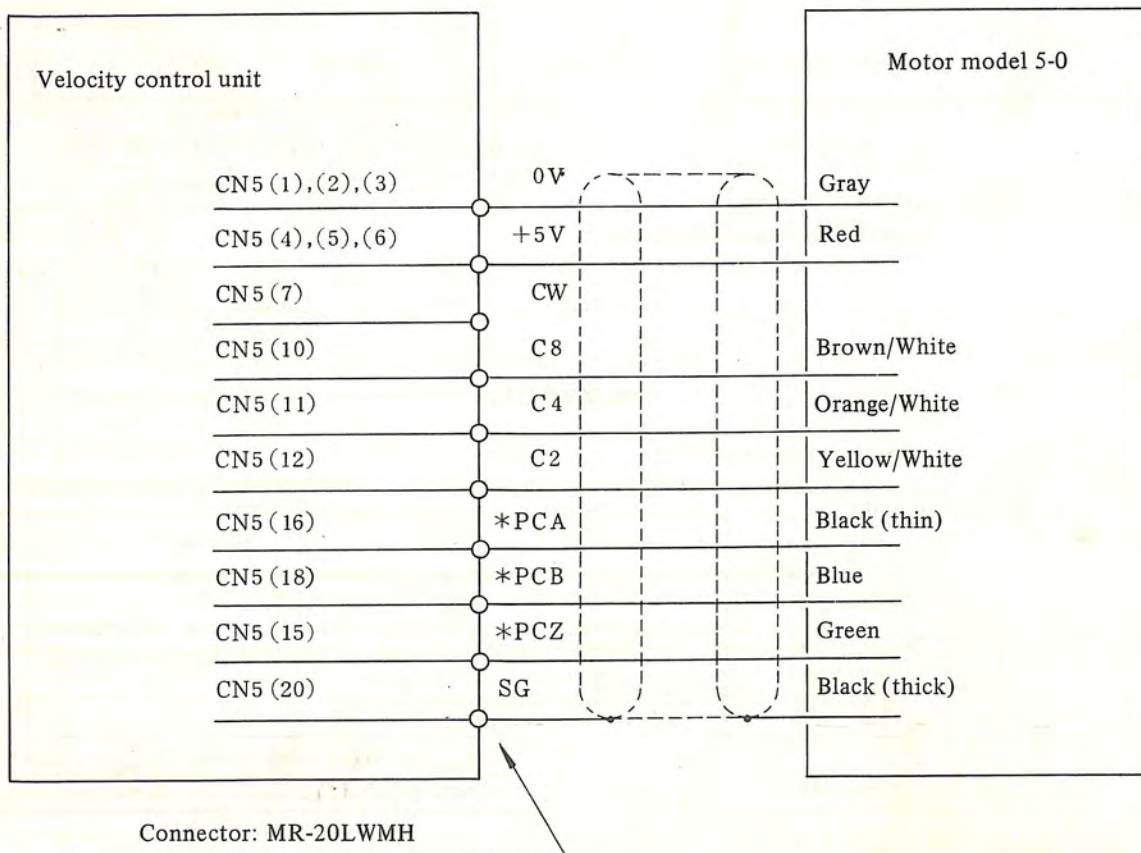

Fig. 2.2.6 (a)

(2) Model 4-0, 3-0

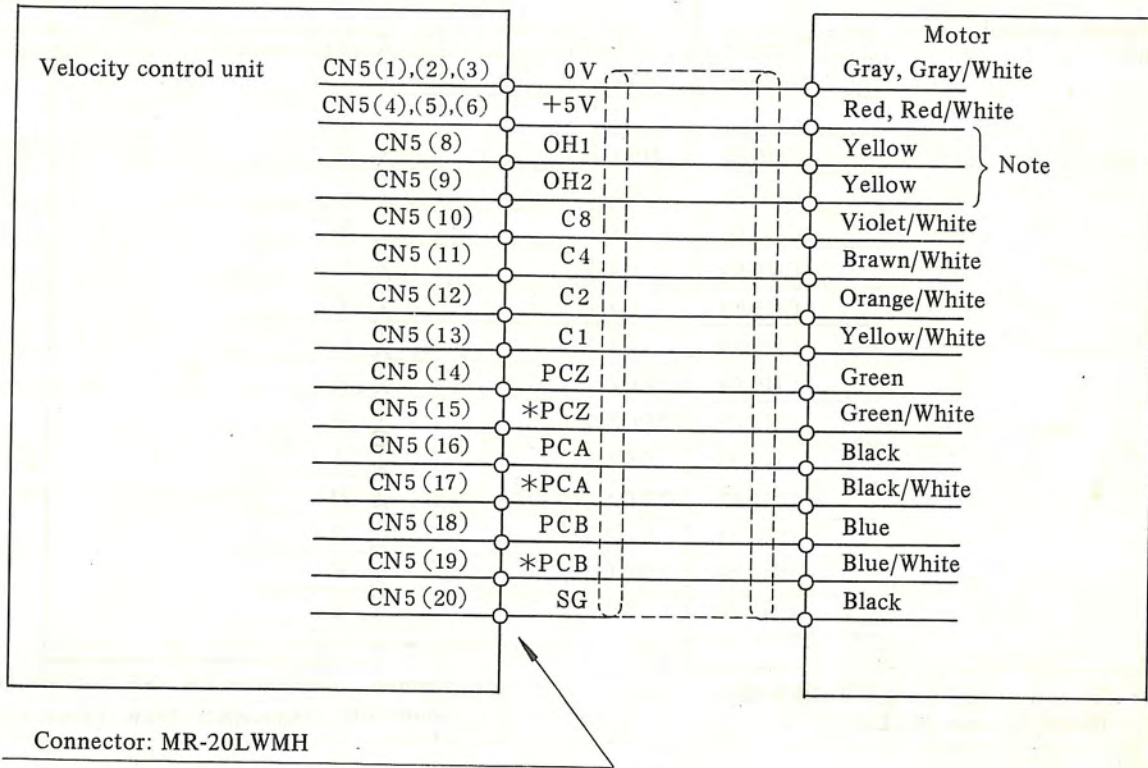

Fig. 2.2.6 (b)



(3) Model 2-0 - 30R

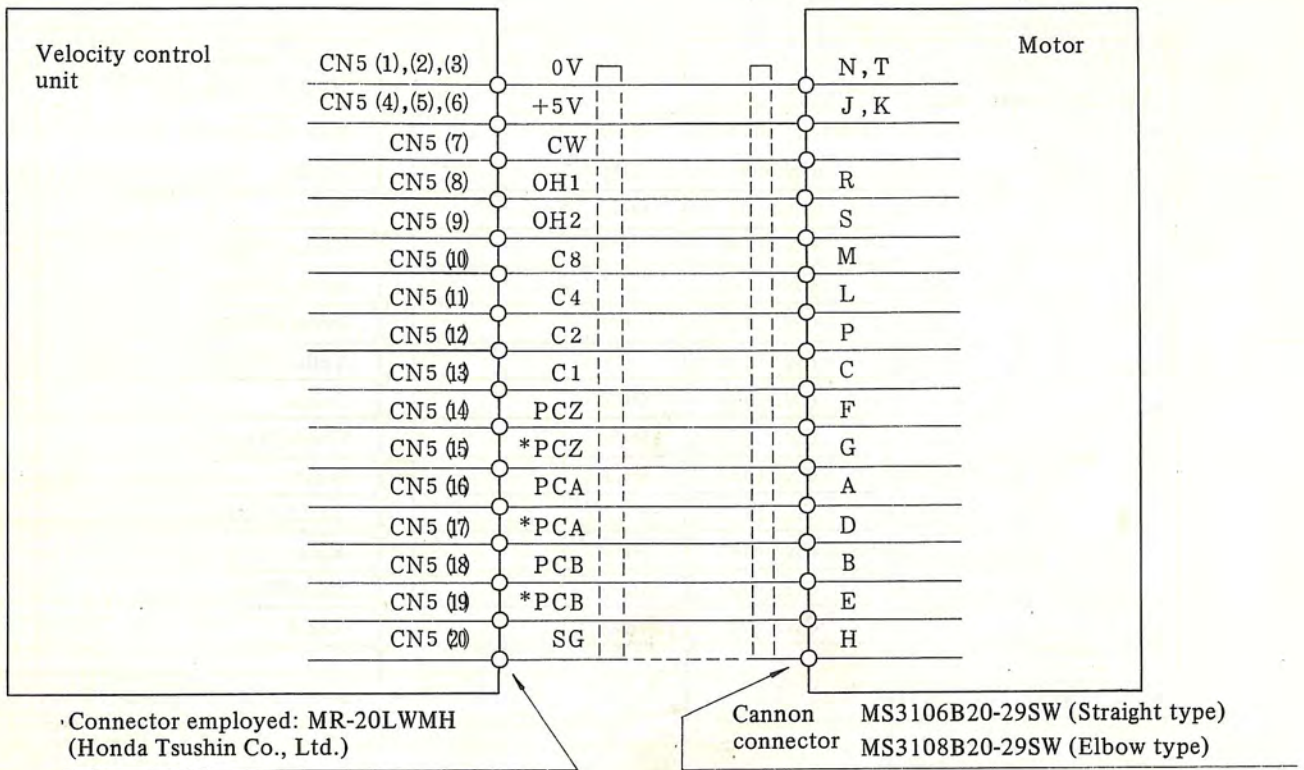
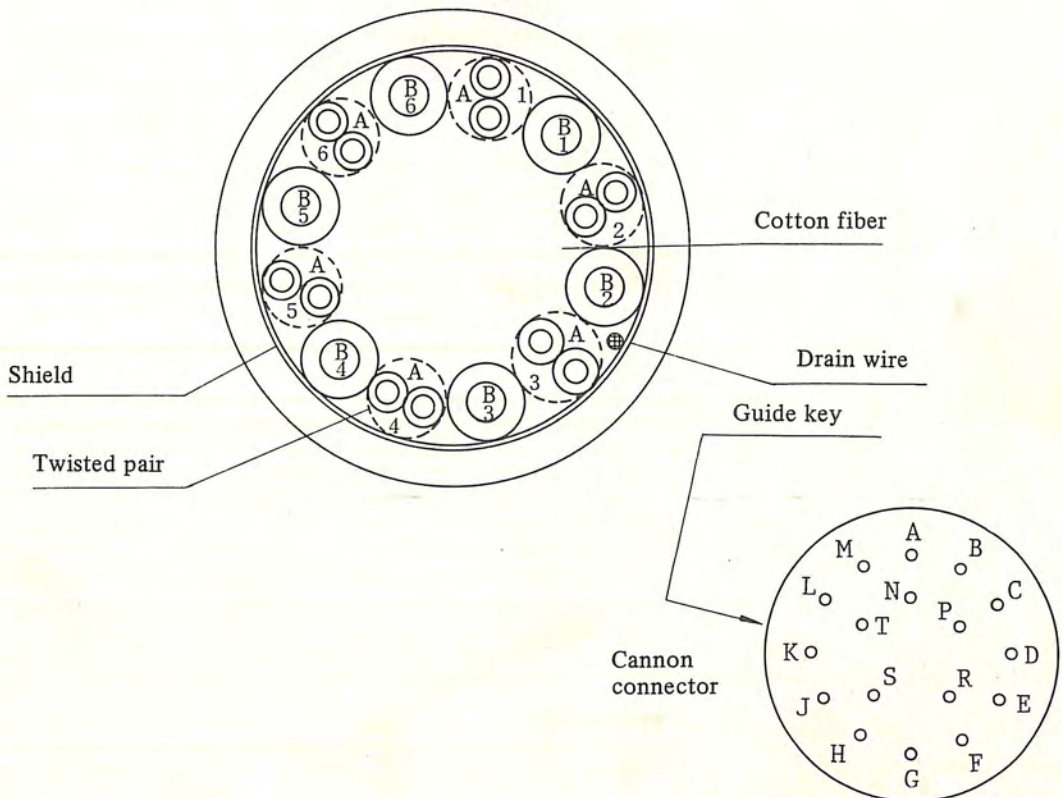
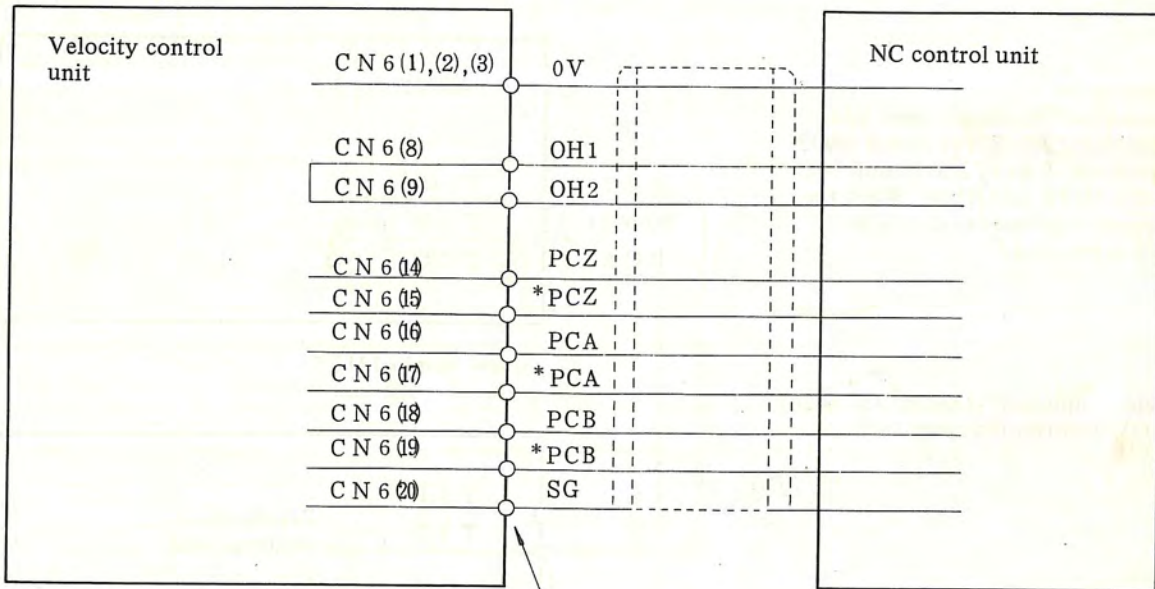

Fig. 2.2.6 (c)



2.2.7 Details of connections of cable K7



Connector employed: MR-20LWFH  
(Honda Tsushin Co., Ltd.)

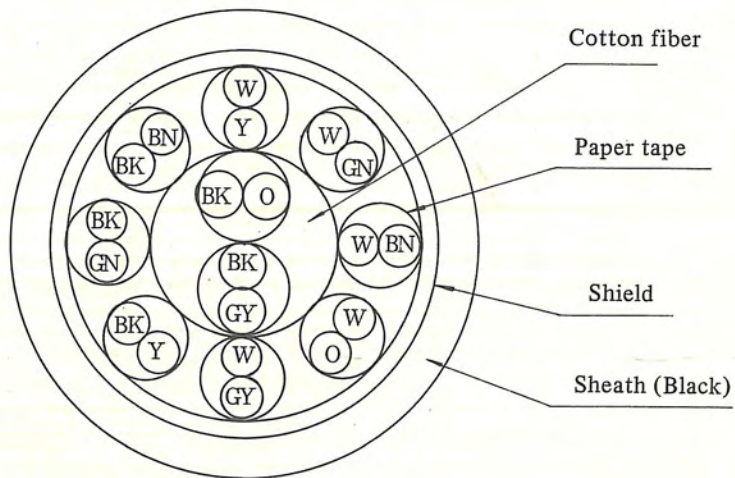

Fig. 2.2.7 (a)

## 2.2.8 Connections of separate regenerative discharge unit

(1) Details of connection of separate regenerative discharge unit.

Note 1)  
Disconnect the jumper wire from terminals T2(5)-T2(6) in unit H003 and H004, T2(4)-T2(5) in unit H103, H113, and H104. When the separate regenerative discharge unit is employed.

Cable employed: 2.0mm<sup>2</sup> (37/0.26)  
600V heat-resistant vinyl cable

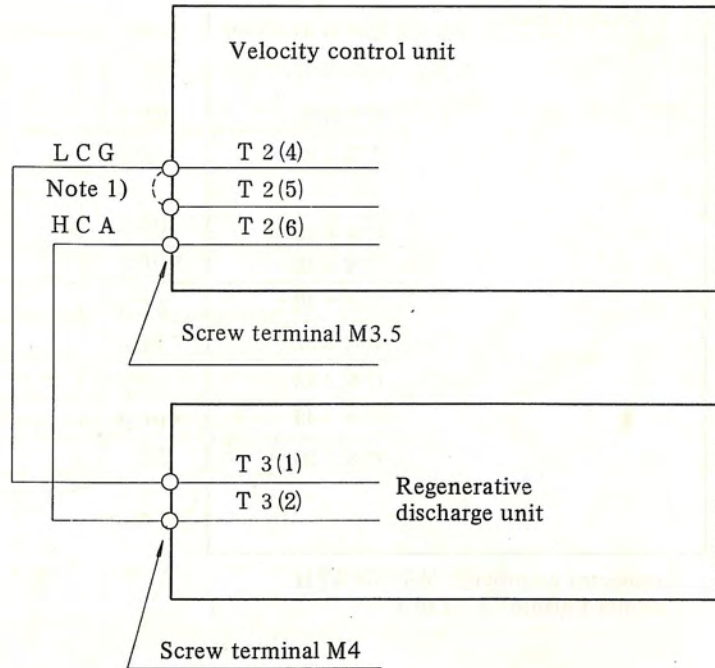

Fig. 2.2.8 (a)

(2) Details of cable K2

For connections of cable K2 in 2.2.2, change the connection of TOH1 and TOH2 as follows.

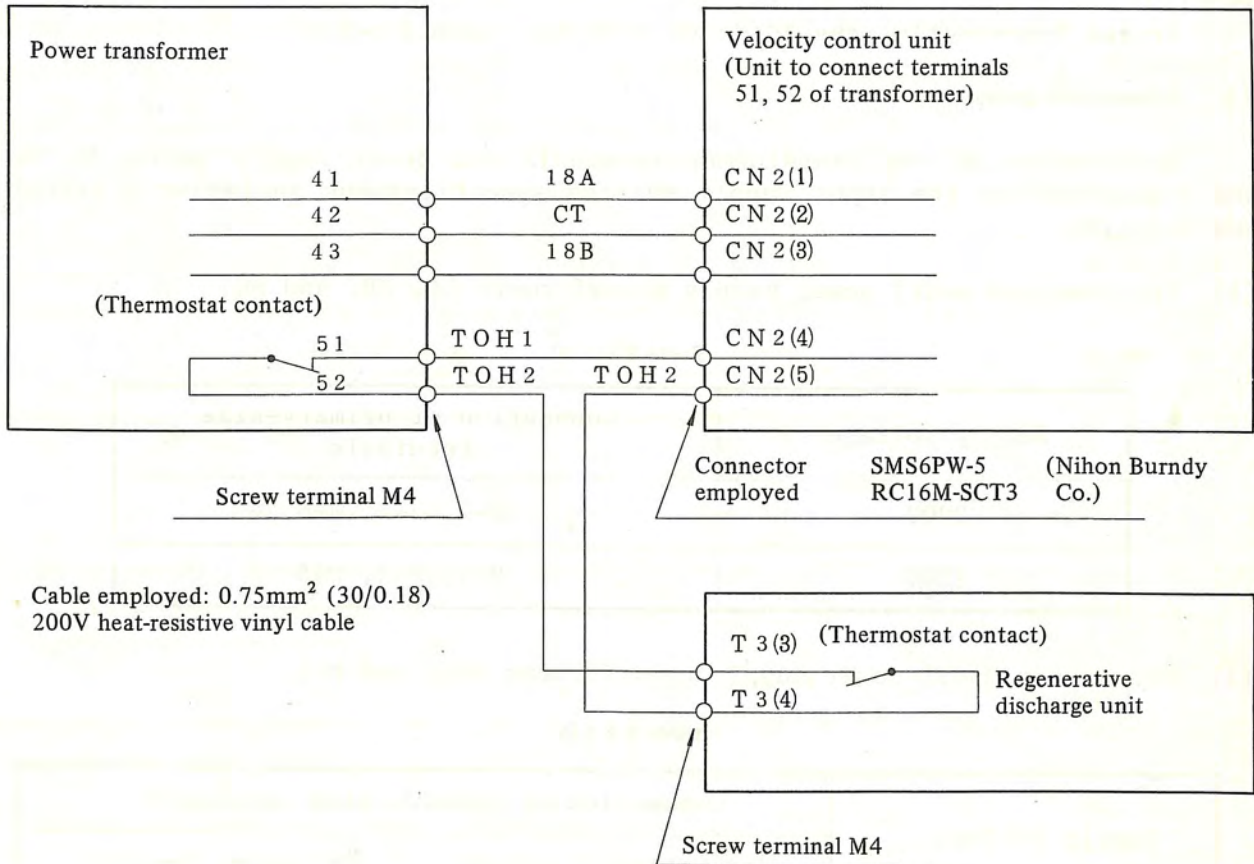

Fig. 2.2.8 (b)

## 2.3 Connection of Power Supply Transformer Tap

More sure the input tap of the power supply transformer is set according to the input voltage when connecting the power supply cable to the AC servo unit.

If set incorrectly, the AC servo unit may cause trouble.

### 2.3.1 Primary side connection

Connections of the transformer terminals and power supply cables U, V, and W must follow the input supply voltage specifications in Tables 2.3.1(a) and 2.3.1(b).

- (1) For Japanese model power supply transformers AA, MB, and MC.

Table 2.3.1 (a)

Supply voltage	Connection of primary-side terminals
200V	U-2, V-4, W-6
220V	U-1, V-3, W-5

- (2) For export model power supply transformers MBE, and MCE.

Table 2.3.1 (b)

Supply voltage	Connection of primary-side terminals	
	Connection of power supply cables U, V, W	Strapping transformer terminals
190V (Common to 200V)	U-3-7, V-11-15, W-19-23	4-8-12-16-20-24
230V (Common to 220V)	U-2-6, V-10-14, W-18-22	
380V	U-3, V-11, W-19	4-7, 12-15, 20-23, 8-16-24
420V (Common to 415V/440V)	U-3, V-11, W-19	4-6, 12-14, 20-22, 8-16-24
460V (Common to 480V)	U-2, V-10, W-18	4-6, 12-14, 20-22, 8-16-24
550V	U-1, V-9, W-17	4-5, 12-13, 20-21, 8-16-24

(3) For common model power supply transformers AAE, ABE and ACE.

Table 2.3.1 (c)

Supply voltage	Connection of primary-side terminals	
	Connection of power supply cables U, V, W	Strapping transformer terminals
200V	U-7, V-15, W-23	8-15, 16-23, 24-7
220V	U-6, V-14, W-22	8-14, 16-22, 24-6
230V	U-5, V-13, W-21	8-13, 16-21, 24-5
240V	U-4, V-12, W-20	8-12, 16-20, 24-4
Delta connection		
380V	U-6, V-14, W-22	8-16, 16-24 or (8-16-24)
420V	U-4, V-12, W-20	
460V	U-3, V-11, W-19	
480V	U-2, V-10, W-18	
550V	U-1, V-9, W-17	
Star connection		

Remarks

If more than one power supply transformer is used, both must be connected to the tap in the same way. Also the connection of transformer overheat must be done in the same manner.

### 2.3.2 Connections in the power supply transformer

#### Domestic models

Connections for power supply transformers AA, MB, and MC  
(Connection for 31-36 of AA is as shown right.)

Connections for power supply transformers AA 31 to 36.

Terminal array of power supply transformers AA, MB, and MC

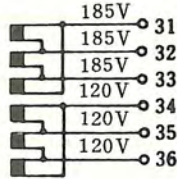
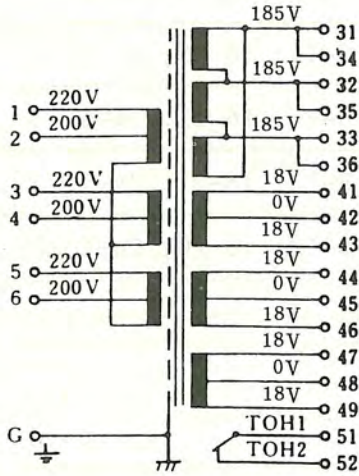

1
2
3
4
5
6



31
32
33
34
35
36
41
42
43
44
45
46
47
48
49
51
52

#### Export models

Connections for power supply transformers MBE, and MCE.

Terminal array of power supply transformers MBE, and MCE.

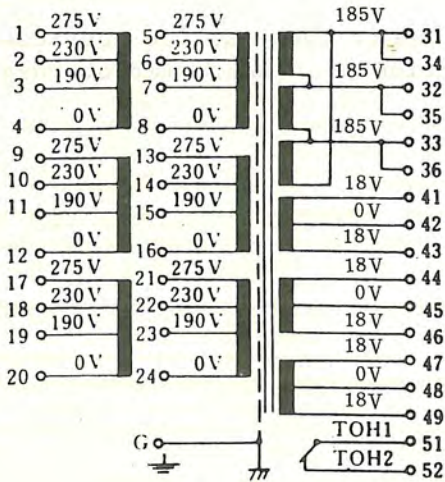

1	5
2	6
3	7
4	8
9	13
10	14
11	15
12	16
17	21
18	22
19	23
20	24



31
32
33
34
35
36
41
42
43
44
45
46
47
48
49
51
52

Connections for power supply transformer AAE.

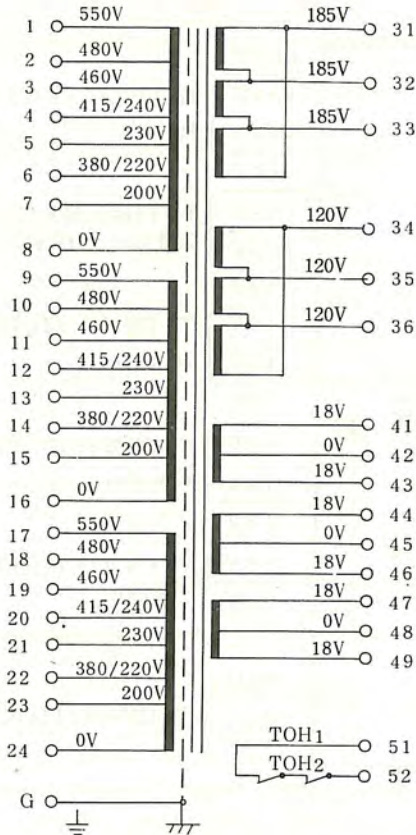

Terminal array of power supply transformer AAE.

5	1	31
6	2	32
7	3	33
8	4	34
13	9	41
14	10	42
15	11	43
16	12	44
21	17	45
22	18	46
23	19	47
24	20	48
		49
		51
		52

G  $\perp$

Connection for power supply transformer ABE and ACE.

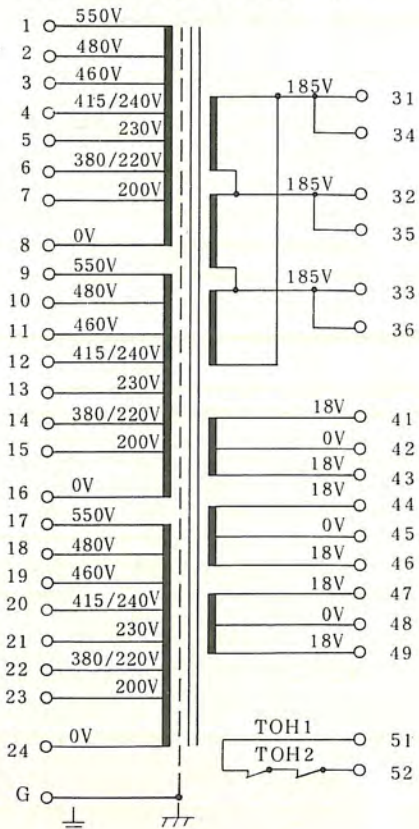

Terminal array of power supply transformer ABE and ACE.

5	1	31
6	2	32
7	3	33
8	4	34
13	9	41
14	10	42
15	11	43
16	12	44
21	17	45
22	18	46
23	19	47
24	20	48
		49
		51
		52

G  $\perp$



(1) For power supply transformers AA and AAE

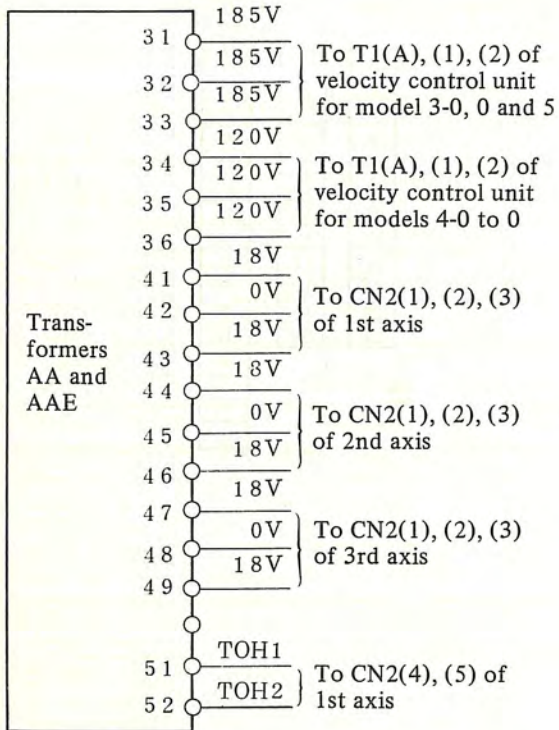

(2) For power supply transformers MB, MC, MBE, MCE, ABE and MCE

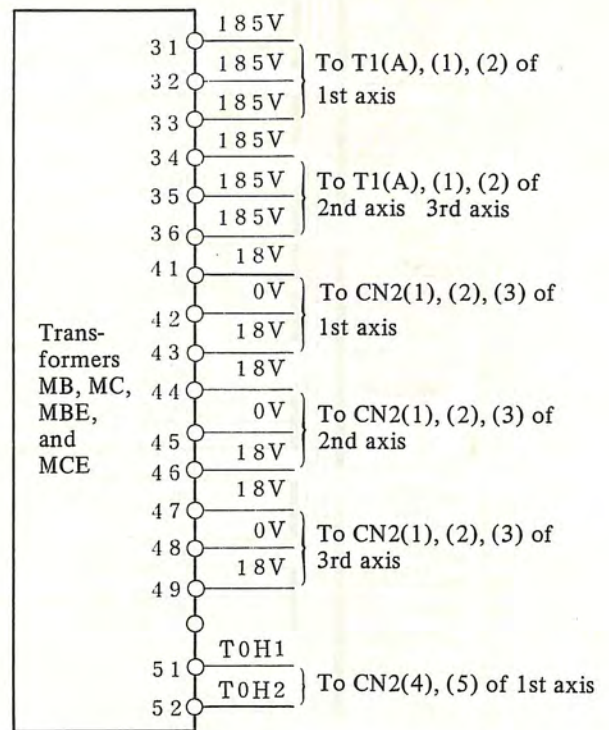

Note: The Model 4-0, 2-0 and 0 motor use a relatively low power supply transformer voltage. If the higher voltage used for the other models is applied to the velocity control unit for Model 4-0 to 0, it will cause a fault.

### 2.3.3 Motors and power transformers employed for each axis

Table 2.3.3

1st axis	2nd axis	3rd axis	Power transformer	Remarks
Model 4-0, 3-0, 2-0	Model 4-0, 3-0, 2-0	Model 4-0, 3-0, 2-0	Transformer AA(AAE) (1.5 kVA)	Model 4-0, 2-0, 1-0, and 0 employ transformer output terminals 34, 35, 36, while Model 3-0, and 0, 5 employ transformer output terminals 31, 32, 33.
Model 4-0, 3-0, 2-0	Model 4-0, 3-0, 2-0	Model 5		
Model 4-0, 3-0, 2-0, 1-0	Model 1-0, 0			
Model 4-0, 3-0, 2-0, 1-0, 0	Model 5			
Model 5	Model 5	Model 5	Transformer MB(MBE, ABE) (2.5 kVA)	
Model 5, 10	Model 10			
Model 20, 30				
Model 5	Model 5	Model 10	Transformer MC(MCE, ACE) (5 kVA)	See Note.
Model 5	Model 20, 30	Model 30		
Model 30R				

Note: Two or more transformers MC, MCE or ACE become necessary according to the load conditions in case of Model 10, 20, 30 x 3 axis. For details, contact FANUC LTD., referring to AC servo motor selection data sheet.

## 2.4 Connection Diagram of Velocity Control Unit

### 2.4.1 For Model 2-0, 1-0 (A06B-6050-H002)

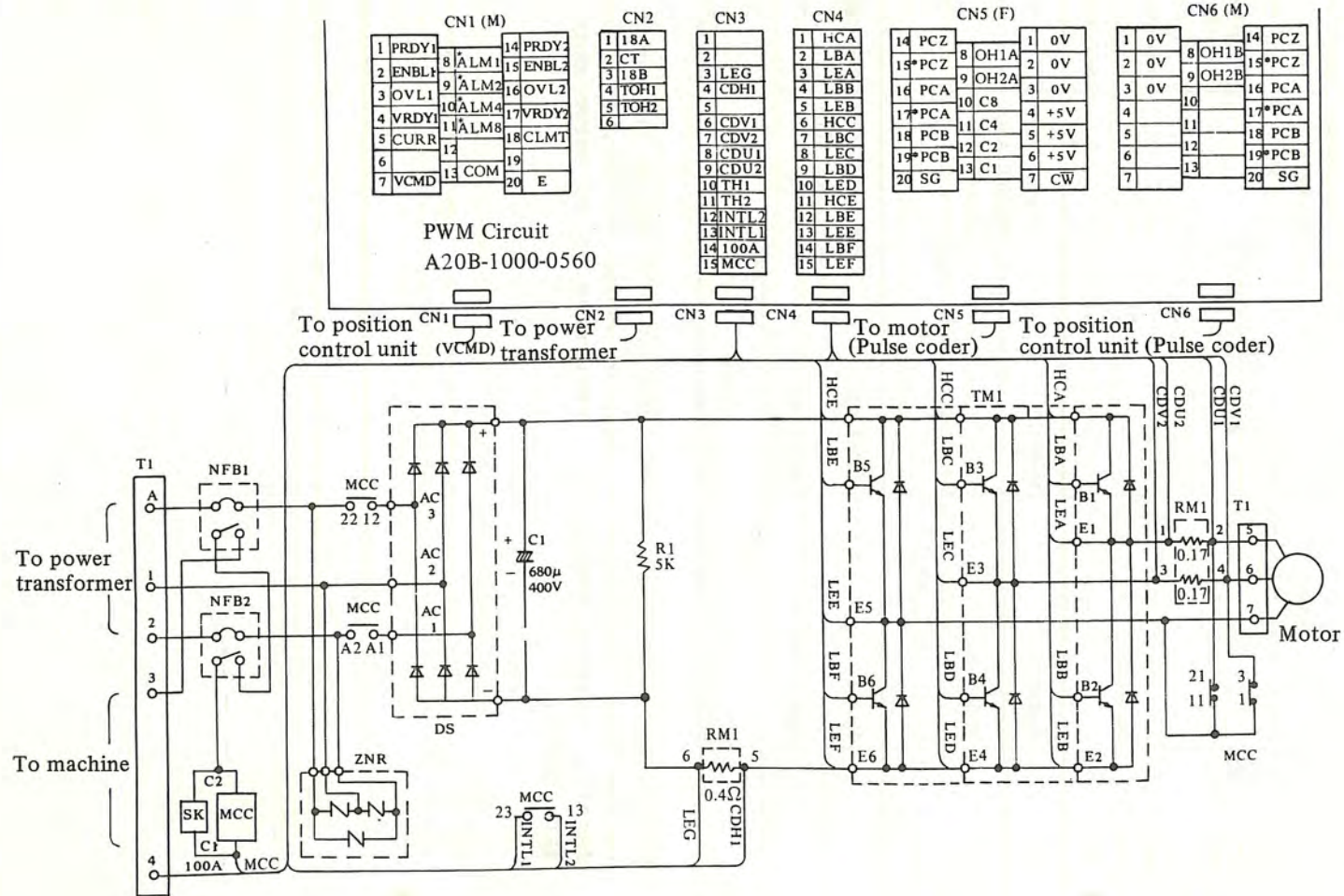

Fig. 2.4.1 Connection Diagram for Velocity Control Unit

2.4.2 For Model 0, 5 (A06B-6050-H102)

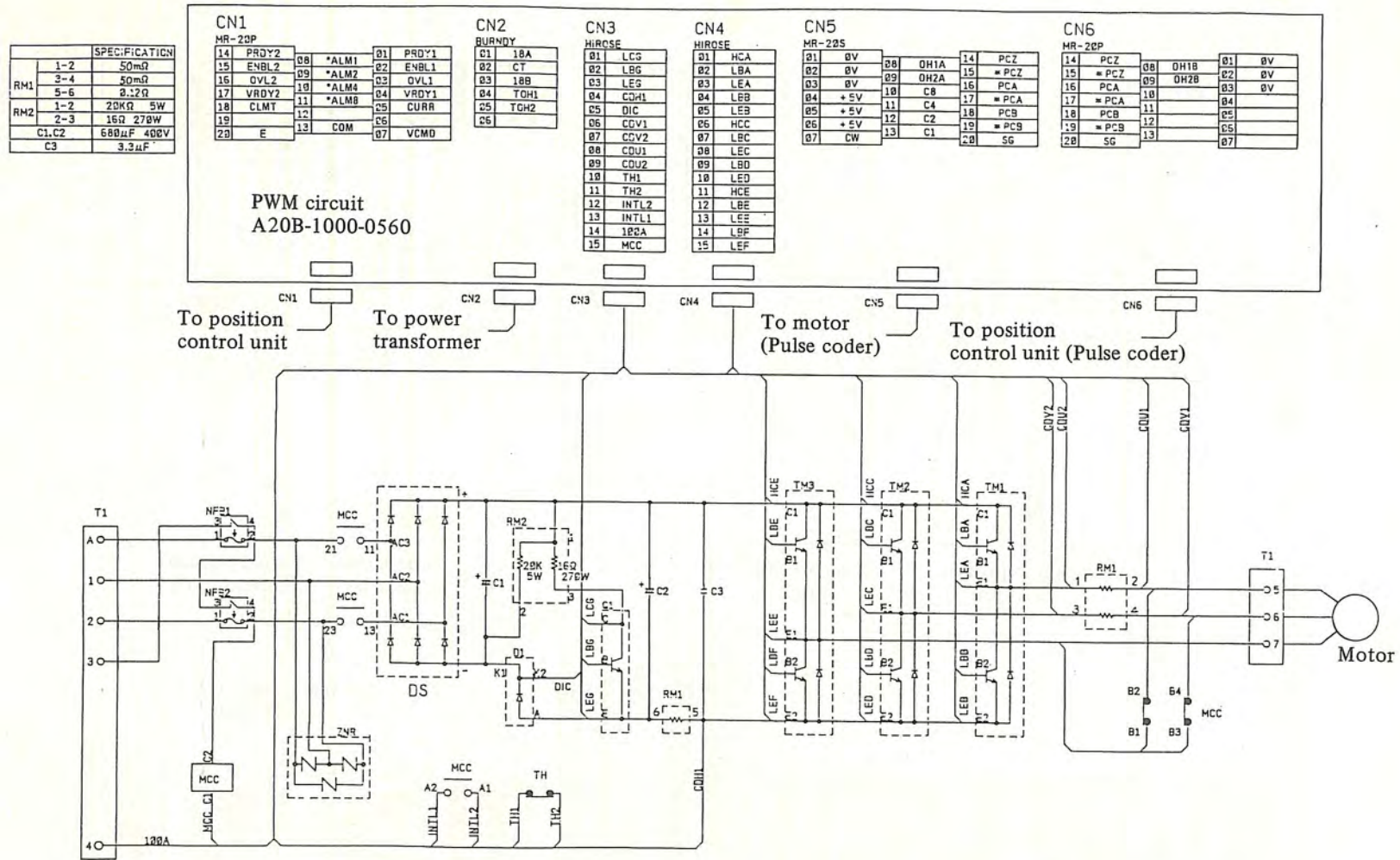

Fig. 2.4.2 Connection Diagram for Velocity Control Unit

2.4.3 For Model 10, 20M, 20, 30 (A06B-6050-H103, H113, H104)

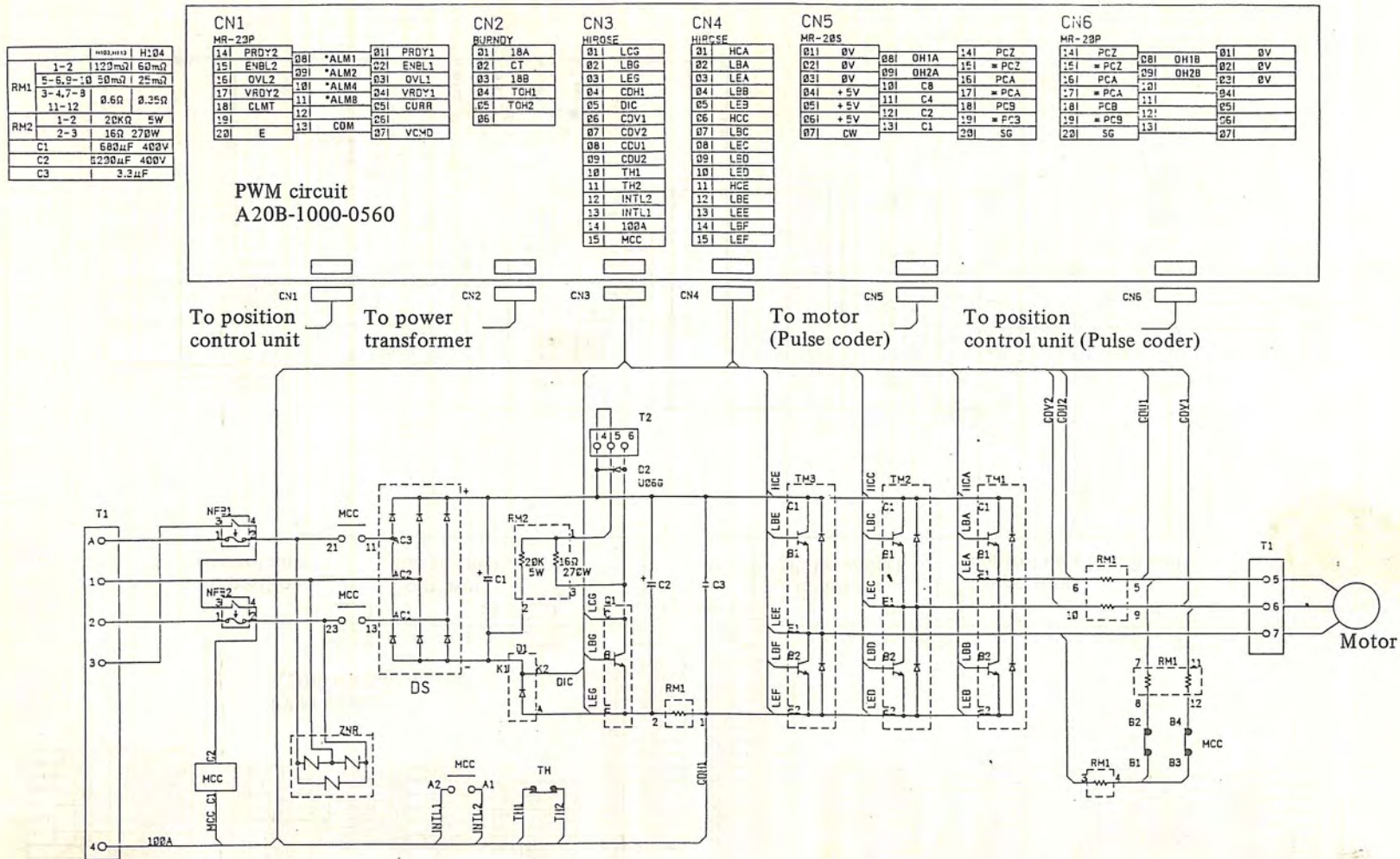

Fig. 2.4.3 Connection Diagram for Velocity Control Unit

2.4.4 In case Model 30R (A06B-6050-H005)

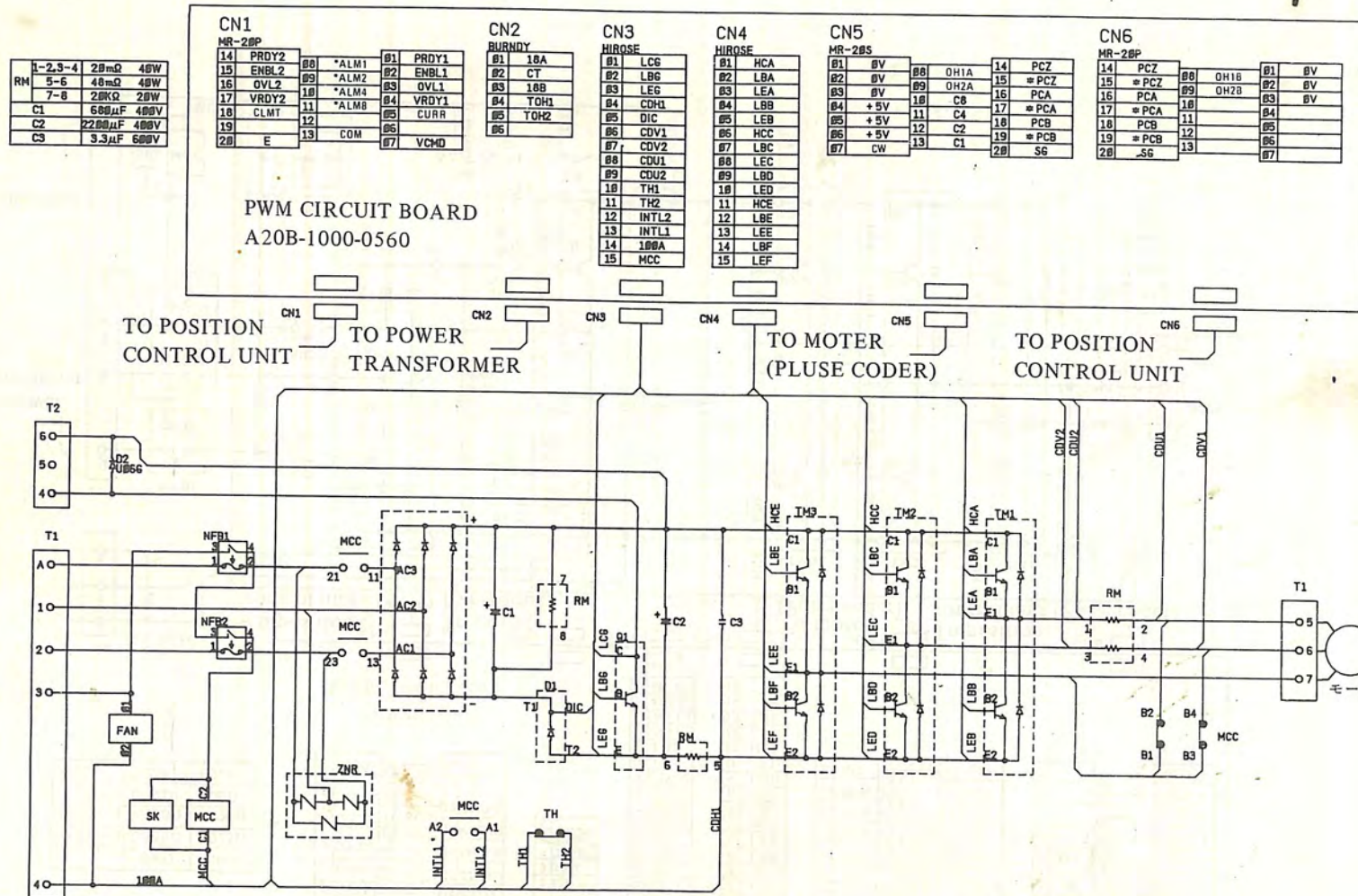

Fig. 2.4.3 Connection Diagram for Velocity Control Unit

2.4.5 For Model 0 - 30 (A06B-6050-H003, H004)

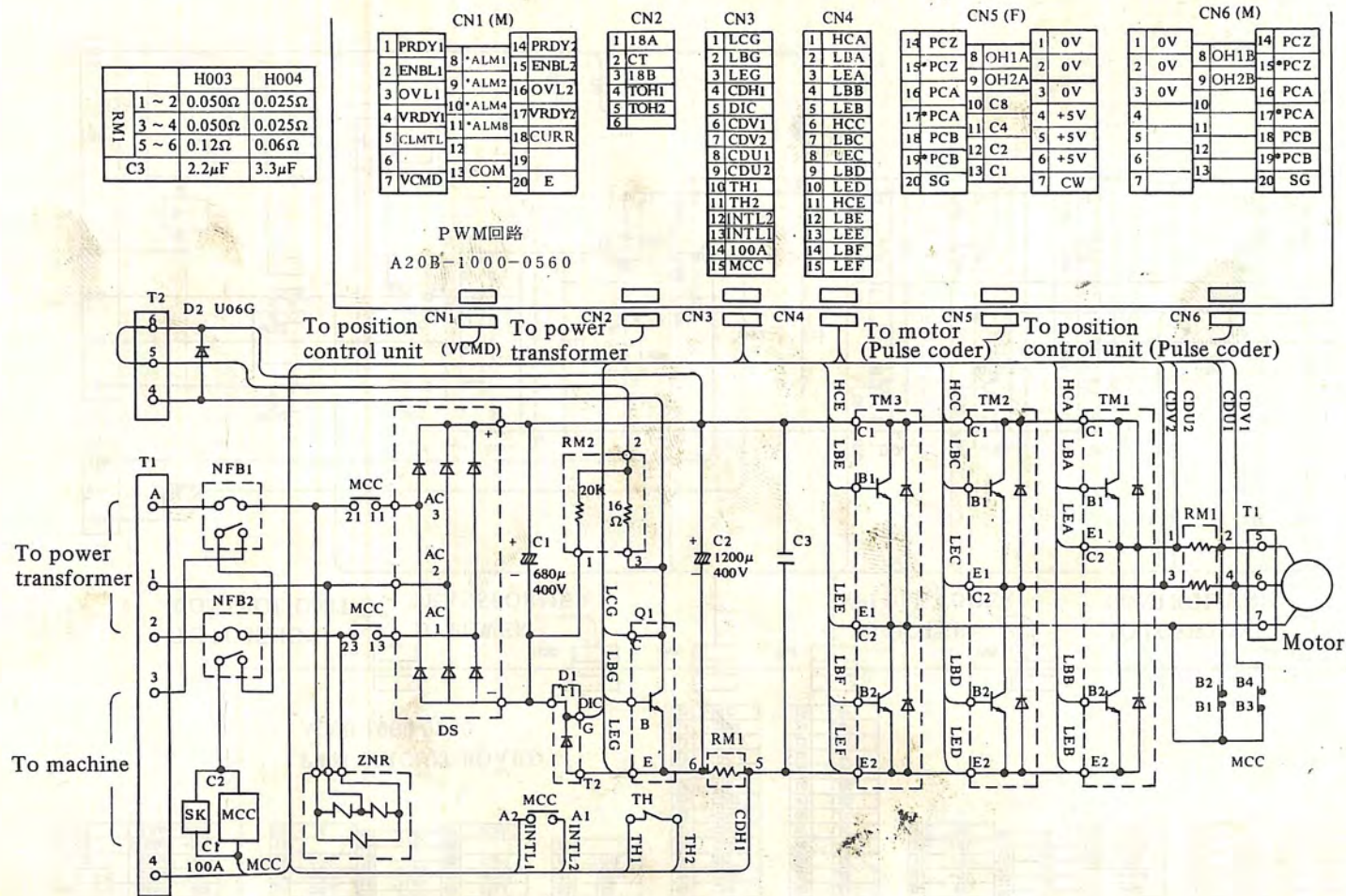

Fig. 2.4.5 Connection Diagram for Velocity Control Unit

### 3. SETTING AND ADJUSTMENT FOR VELOCITY CONTROL UNIT

#### 3.1 Setting and Adjustment for Velocity Control PCB

##### 3.1.1 Parts location

- (1) For Model 2-0 to 30R
  - (a) PCB A20B-1000-0560 (After edition number E)

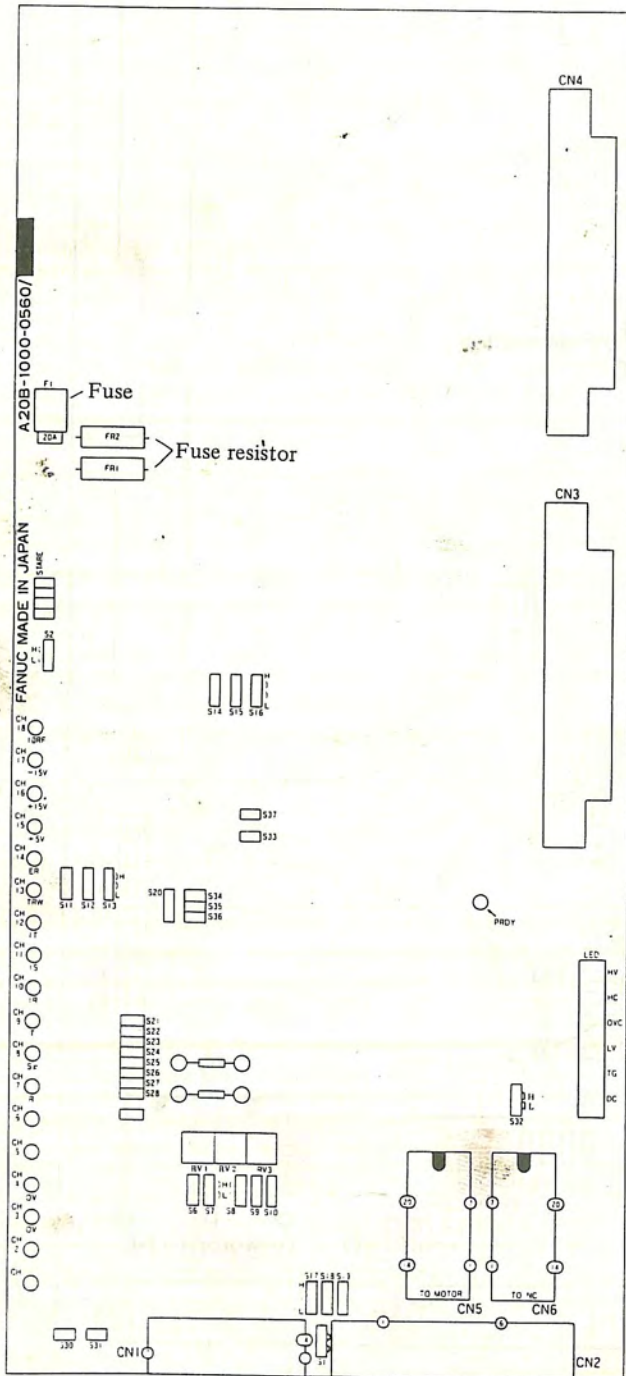

Fig. 3.1.1 (a)

Note: Parts location on PCB may be changed without notice.



(b) PCB A20B-1000-0560 (Edition number E)

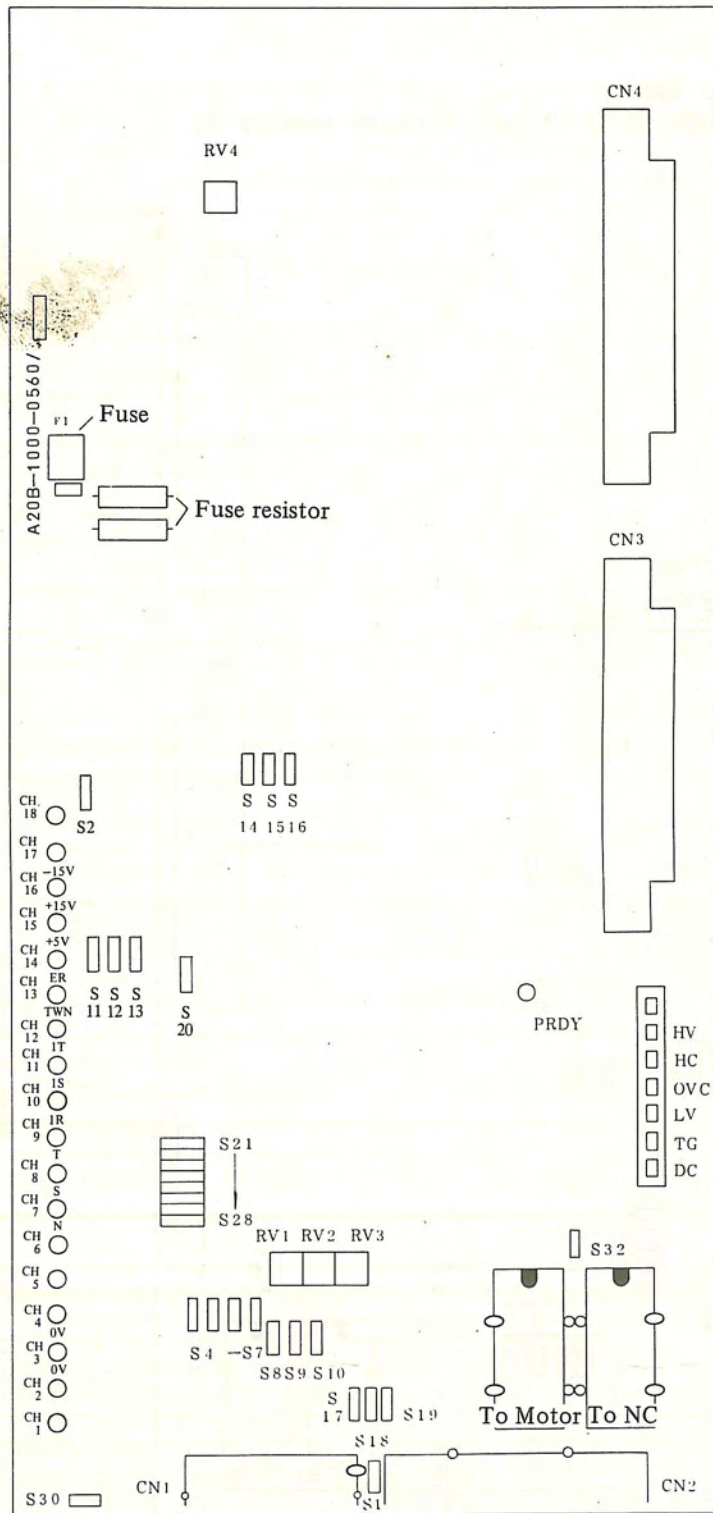

Fig. 3.1.1 (b)

Note: Parts location on PCB may be changed without notice.

(c) PCB A20B-1000-0560 (Edition number C or D)

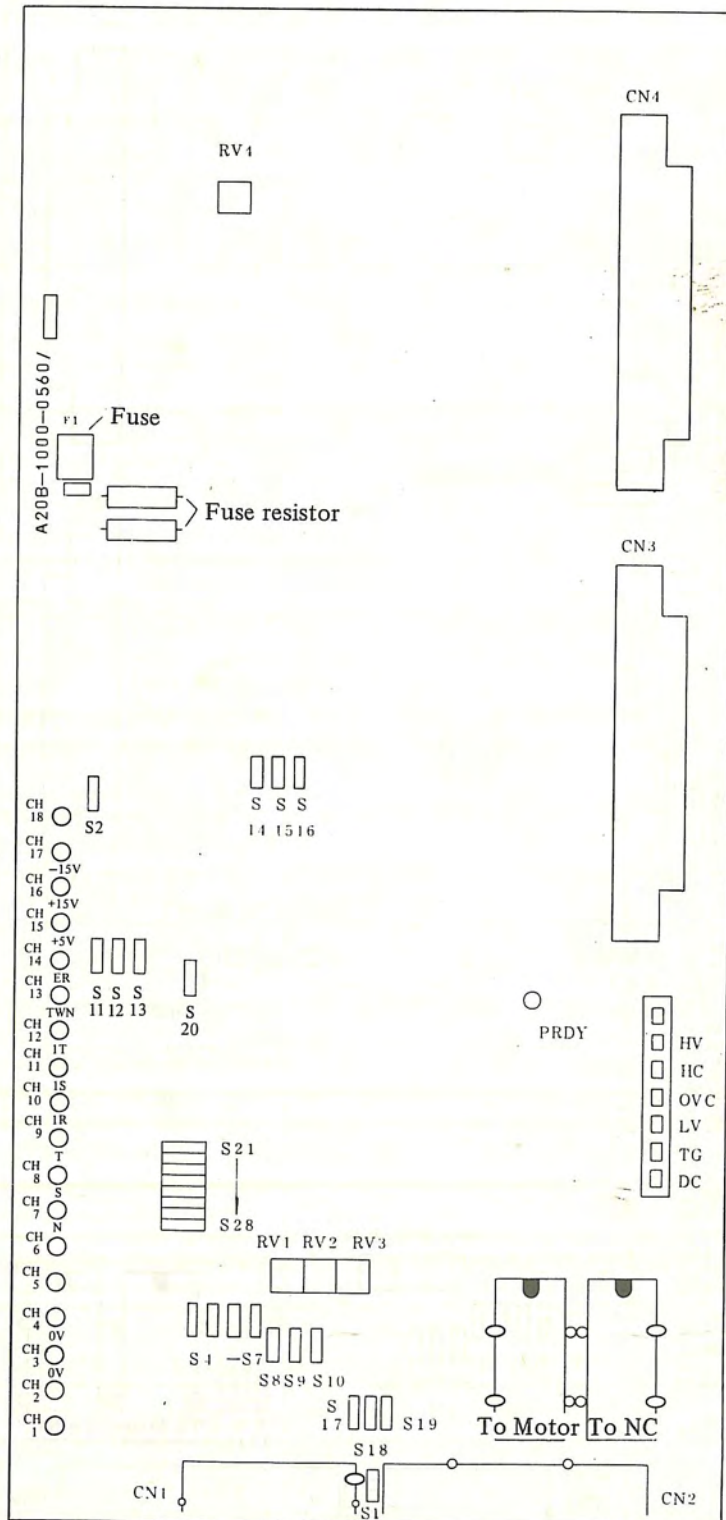

Fig. 3.1.1 (c)

Note: Parts location on PCB may be changed without notice.

(d) PCB A20B-1000-0560 (Edition number A or B)

VIC-7

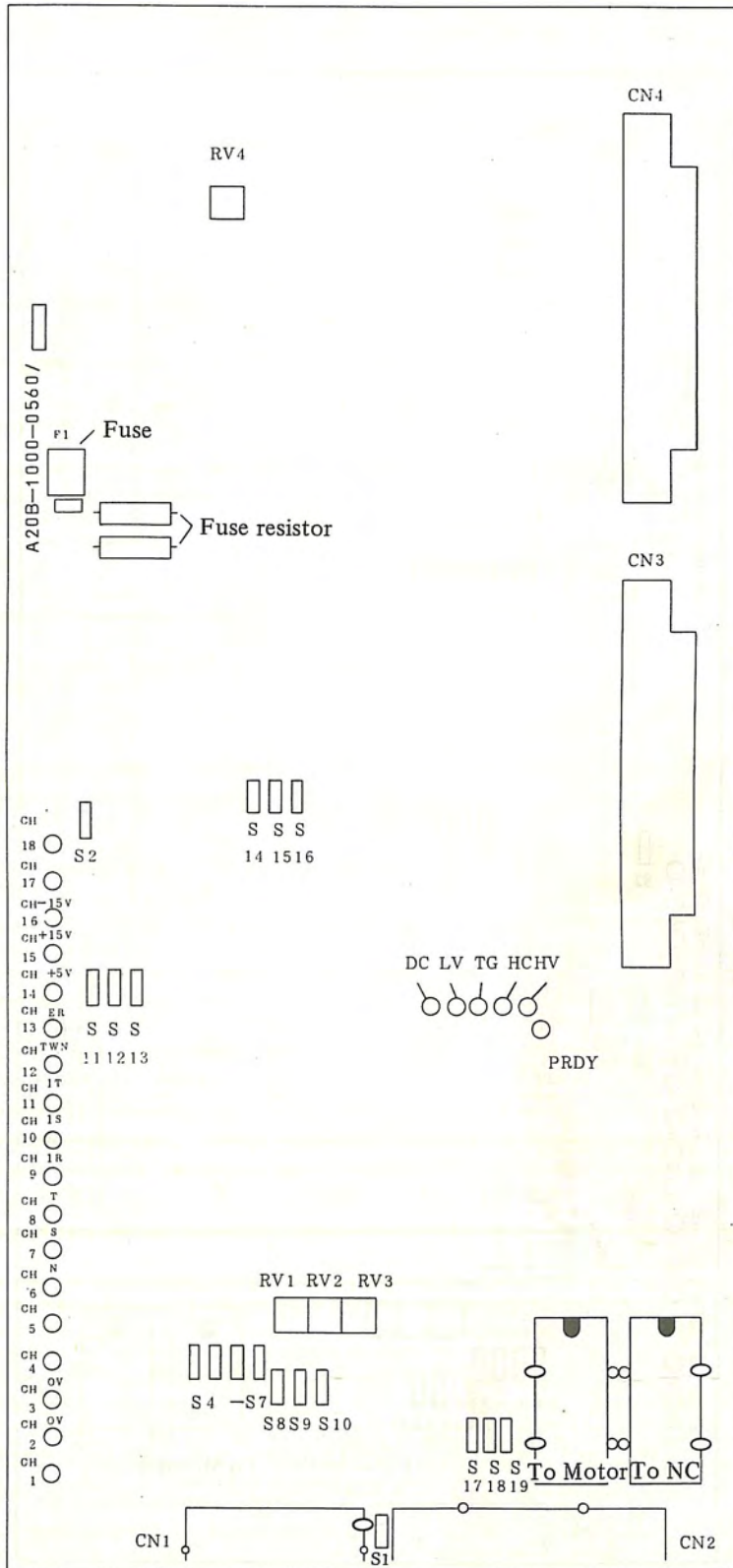

Fig. 3.1.1 (d)

Note: Parts location on PCB may be changed without notice.

- (2) Model 4-0, 3-0  
 (a) PCB A20B-1000-0590 (After edition number B)

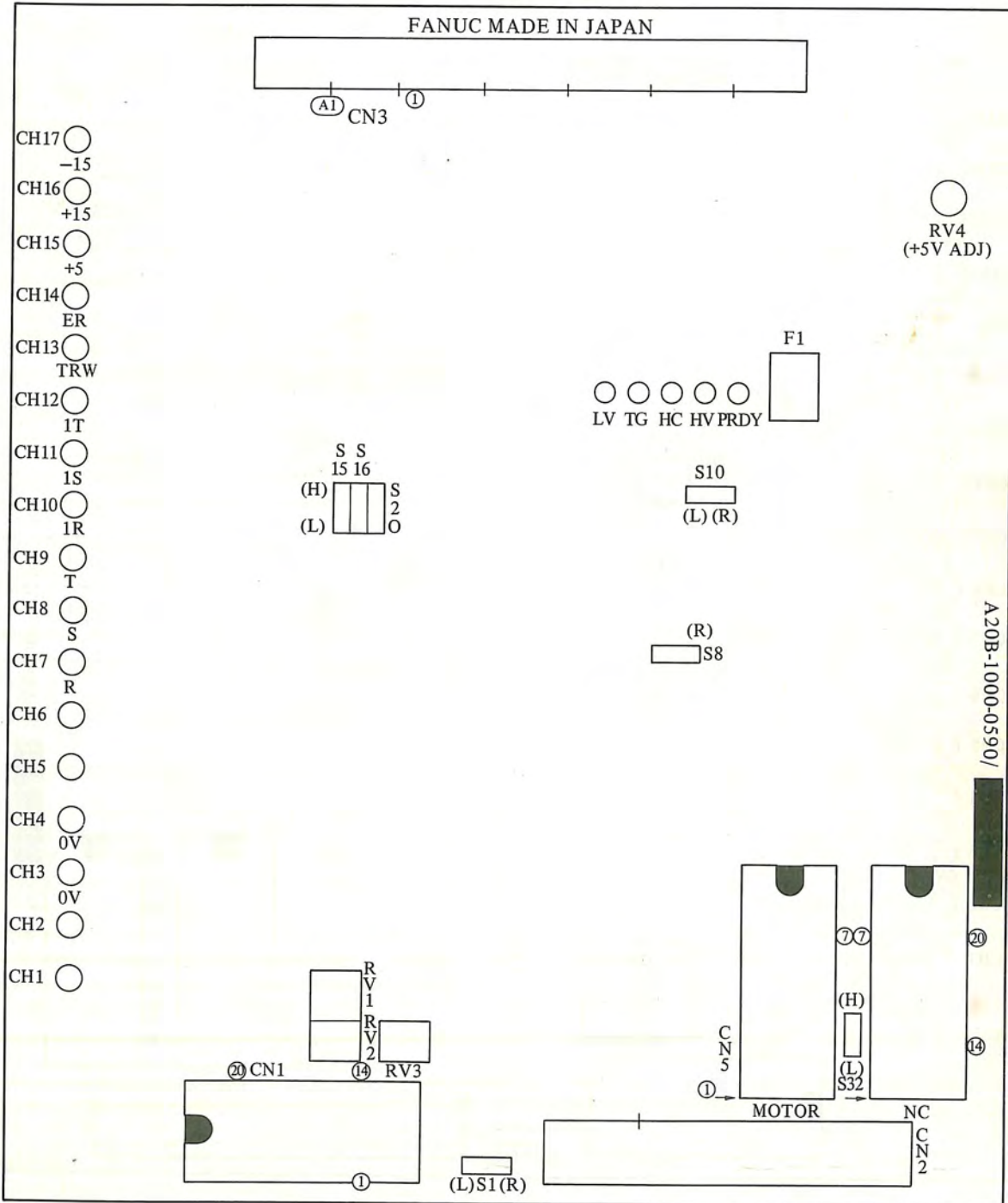

Fig. 3.1.1 (e)

Note: Parts location on PCB may be changed without notice.

(b) A20B-1000-0590 (Edition number A)

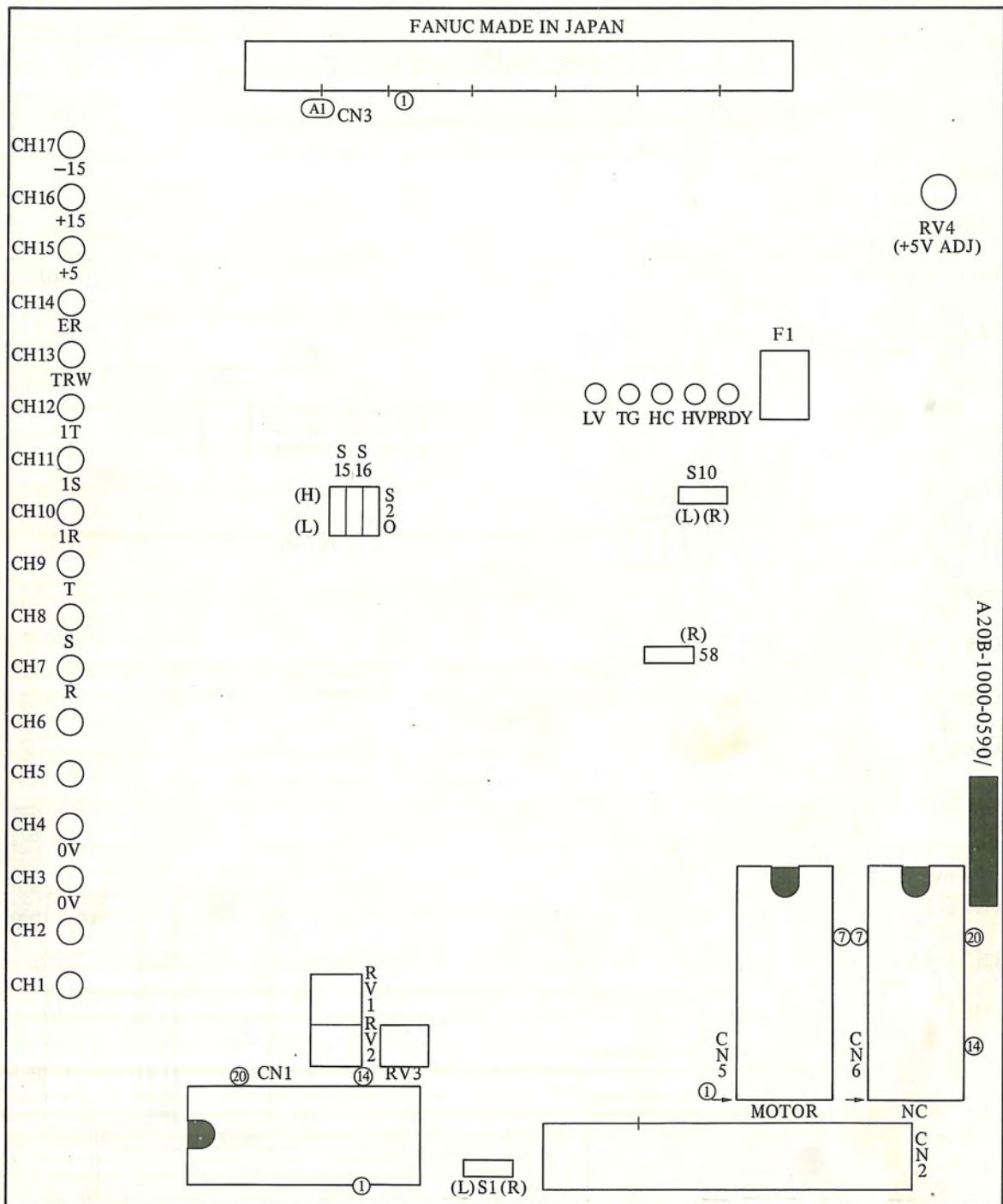

Fig. 3.1.1 (f)

Note: Parts location on PCB may be changed without notice.

(c) For Model 4-0, 3-0 (A20B-1000-0600)

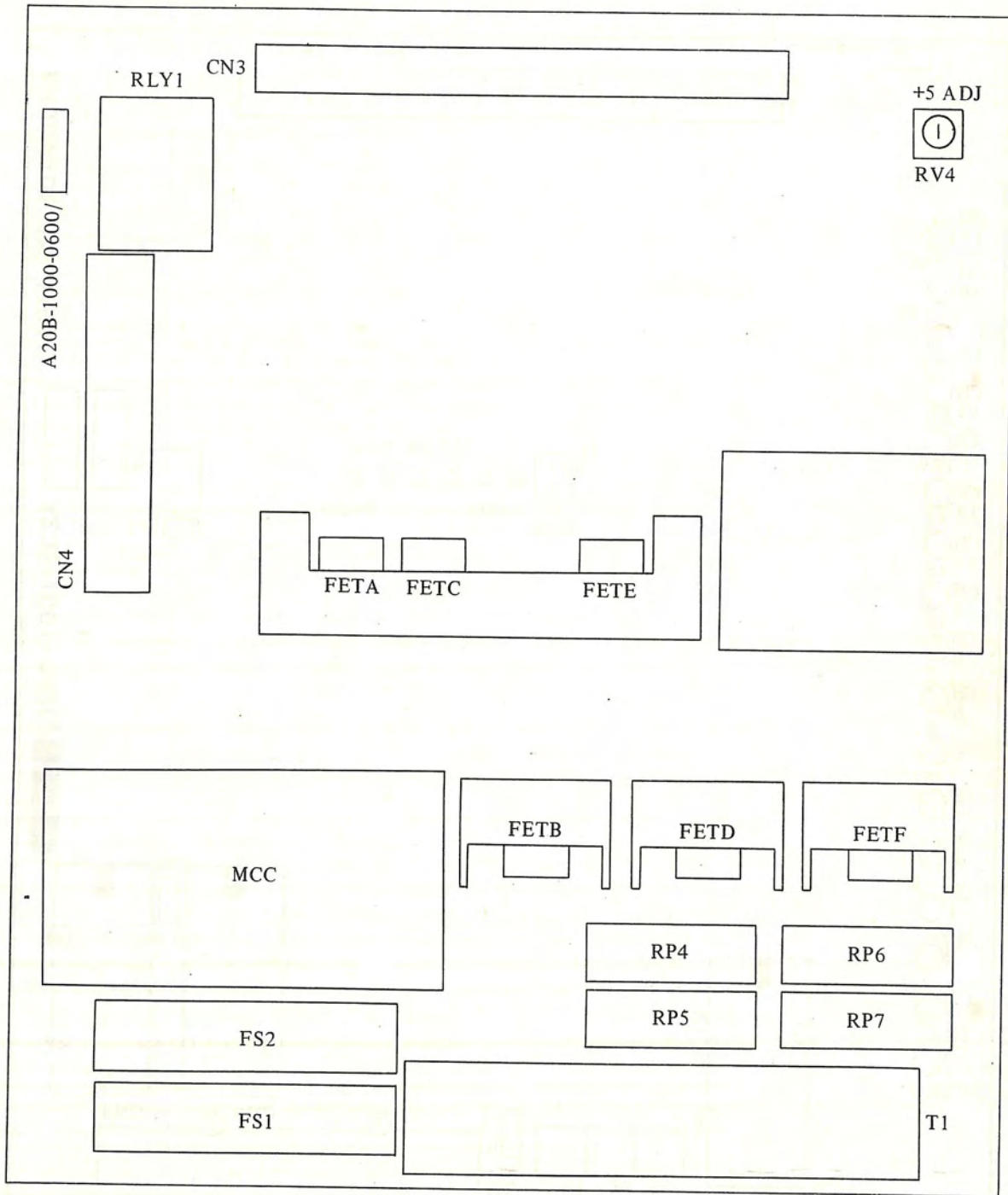

Fig. 3.1.1 (g)

- (3) Model 5-0  
 (a) PCB A20B-1001-0420

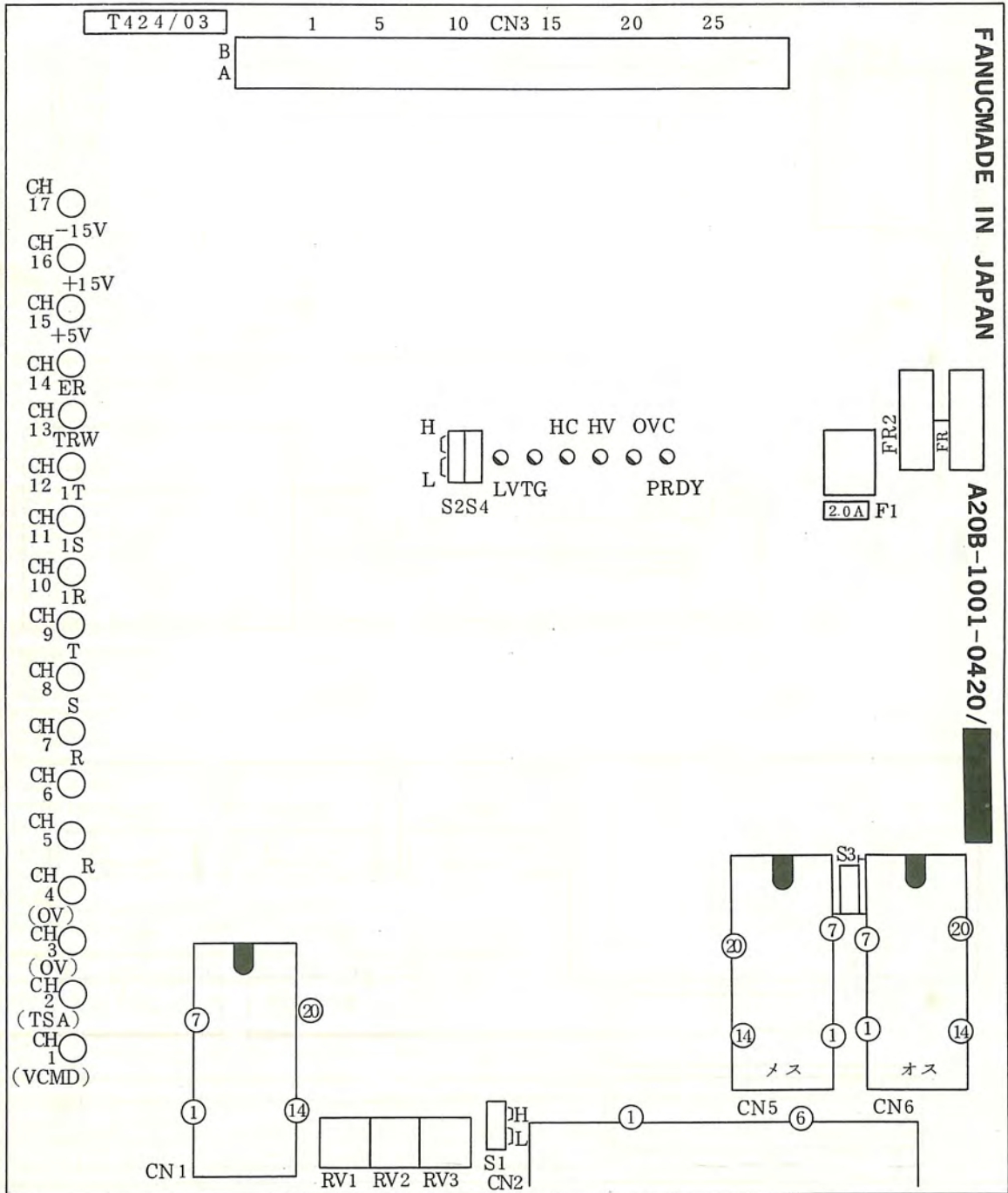

Fig. 3.1.1 (h)

Note: Parts location on PCB may be changed without notice.

(b) PCB A20B-1001-0410

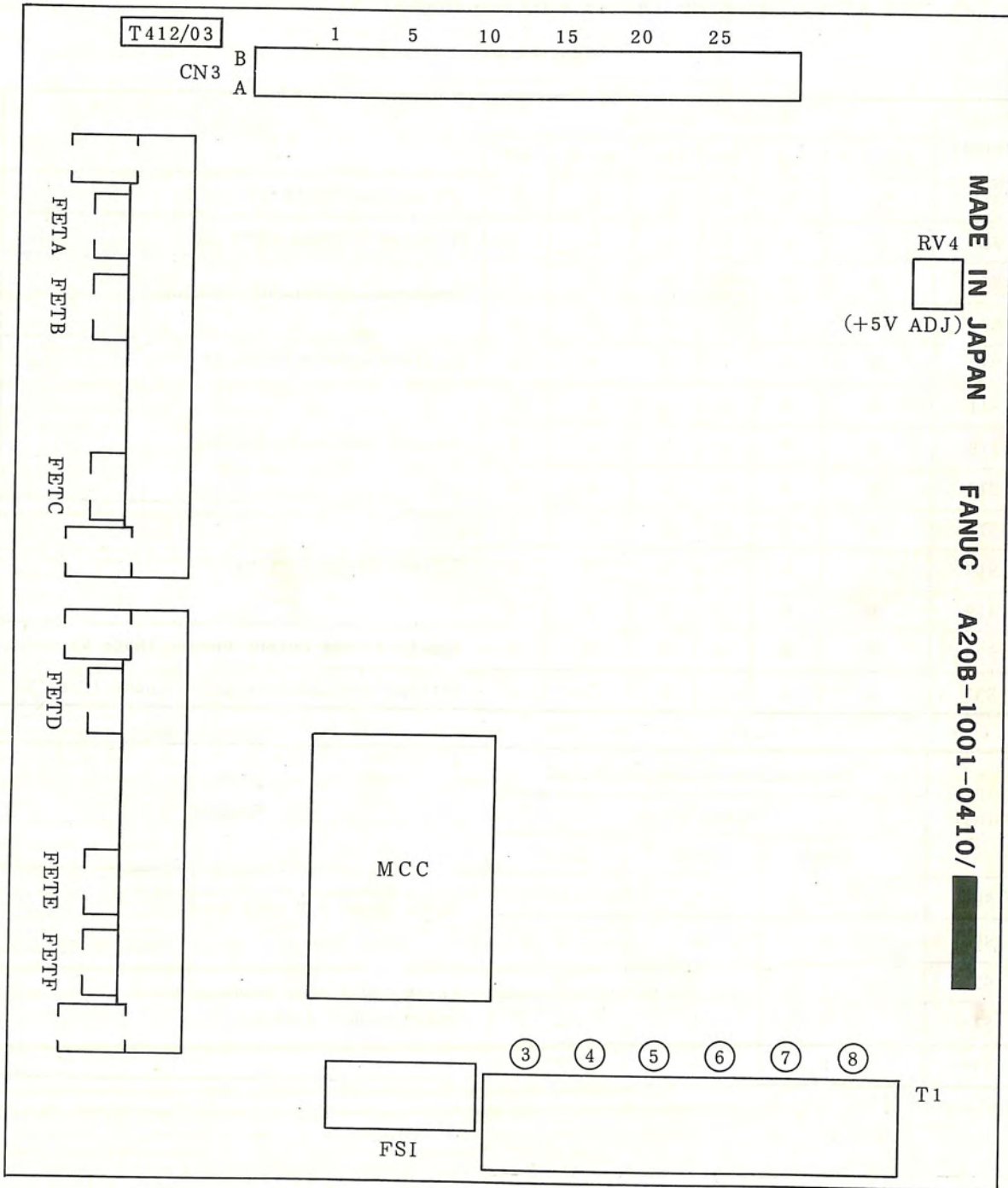

Fig. 3.1.1 (i)

Note: Parts location on PCB may be changed without notice.



### 3.1.2 Setting terminal

(1) Model 2-0 - 30R

(a) PCB A20B-1000-0560 (After edition number F)

Table 3.1.2 (a)

Setting terminal	Standard setting						Remarks
	2-0,1-0	0,5	10	20M	20,30	30R	
S1	L	L	L	L	L	L	TOH setting (Note 1)
S2	L	L	L	L	L	L	DC alarm setting (Note 2)
S6	H	H	H	H	H	H	Compensation circuit setting
S7	H	H	H	H	H	H	
S10	H	H	H	H	H	H	TG alarm enable (Note 3)
S11	H	H	L	L	L	H	Current loop gain setting
S12	H	H	L	L	L	H	
S13	H	H	L	L	L	H	
S17	H	H	H	H	H	L	Current limit setting
S18	H	L	L	L	H	H	
S19	H	H	H	H	H	H	
S20	H	H	H	H	H	H	Absolute code output enable (Note 4)
S32	L	L	L	L	L	L	Setting for absolute pulse coder (Note 5)

Setting terminal	2-0,1-0,0,5,10,20M,20,30,30R			Remarks
	Pulse coder			
	2000P	2500P	3000P	
S8	L	L	H	Pulse coder F/V gain setting
S9	H	L	L	
S14	L	H	H	Pulse coder pole number, and pulse number setting
S15	H	L	L	
S16	H	L	H	

Setting terminal	Standard setting							Remarks
	2-0,1-0	0	5	10	20M	20,30	30R	
S21								Compensation circuit setting
S22								
S23	o	o	o					VCMD gain setting (Note 6)
S24	o	o	o	o	o	o	o	F/V circuit filter setting
S25	o	o	o	o	o	o	o	Compensation circuit setting
S26								
S27								
S28								
S29								
S30								External analog current limiter setting
S31								Connect CN1(19) pin and 0V
S33		o						OVC alarm level setting
S34			o					
S35		o	o	o	o			Current feedback gain setting (Note 7)
S36		o	o	o	o			
S37								Speed feedback gain setting (Note 8)
S38		o	o	o	o			Compensation circuit setting

(b) PCB A20B-1000-0560 (Edition number E)

Table 3.1.2 (b)

Setting terminal	Standard setting					Remarks
	2-0,1-0	0,5	10,20M	20,30	30R	
S1	L	L	L	L	L	TOH setting (Note 1)
S2	L	L	L	L	L	DC alarm setting (Note 2)
S4	L	L	L	L	L	Compensation circuit setting
S5	L	L	L	L	L	
S6	H	H	H	H	H	
S7	H	H	H	H	H	
S10	H	H	H	H	H	TG alarm enable (Note 3)
S11	H	H	L	L	H	Current loop gain setting
S12	H	H	L	L	H	
S13	H	H	L	L	H	
S17	H	H	H	H	L	Current limit setting
S18	H	H	H	H	H	
S19	H	H	H	H	H	
S20	H	H	H	H	H	Absolute code output enable (Note 4)
S32	L	L	L	L	L	Setting for absolute pulse coder (Note 5)

Setting terminal	2-0,1-0,0,5,10,20M,20,30,30R			Remarks
	Pulse coder			
	2000P	2500P	3000P	
S8	L	L	H	Pulse coder F/V gain setting
S9	H	L	L	
S14	L	H	H	Pulse coder pole number, and pulse number setting
S15	H	L	L	
S16	H	L	H	

Setting terminal	Standard setting					Remarks
	2-0,1,0	0,5	10,20M	20,30	30R	
S21						Compensation circuit setting
S22						
S23	o	o				VCMD gain setting (Note 6)
S24	o	o	o	o	o	F/V circuit filter setting
S25	o	o	o	o	o	Compensation circuit setting
S26						
S27						
S28						
S30						External analog current limiter setting

(c) PCB A20B-1000-0560 (Edition number C or D)

Table 3.1.2 (c)

Setting terminal	Standard setting					Remarks
	2-0,1-0	0,5	10	20,30	30R	
S1	L	L	L	L	L	TOH setting (Note 1)
S2	L	L	L	L	L	DC alarm setting (Note 2)
S4	L	L	L	L	L	Compensation circuit setting
S5	L	L	L	L	L	
S6	H	H	H	H	H	
S7	H	H	H	H	H	
S10	H	H	H	H	H	TG alarm enable (Note 3)
S11	H	H	L	L	H	Current loop gain setting
S12	H	H	L	L	H	
S13	H	H	L	L	H	
S17	H	H	L	L	L	Current limit setting
S18	H	H	H	H	H	
S19	H	H	H	H	H	
S20	H	H	H	H	H	Absolute code output enable (Note 4)

Setting terminal	2-0,1-0,0,5,10,20,30,30R			Remarks
	Pulse coder			
	2000P	2500P	3000P	
S8	L	L	H	Pulse coder F/V gain setting
S9	H	L	L	
S14	L	H	H	
S15	H	L	L	Pulse coder pole number, and pulse number setting
S16	H	L	H	

Setting terminal	Standard setting					Remarks
	2-0,1,0	0,5	10	20,30	30R	
S21						Compensation circuit setting
S22						
S23	o	o				VCMD gain setting (Note 6)
S24	o	o	o	o	o	F/V circuit filter setting
S25	o	o	o	o	o	Compensation circuit setting
S26						
S27						
S28						

d) PCB A20B-1000-0560 (Edition number A and B)

Table 3.1.2 (d)

Setting terminal	Standard setting					Remarks
	2-0,1-0	0,5	10	20,30	30R	
S1	L	L	L	L	L	TOH setting (Note 1)
S2	L	L	L	L	L	DC alarm setting (Note 2)
S4	All H or All L					Compensation circuit setting
S5						
S6						
S7						
S10	H	H	H	H	H	TG alarm enable (Note 3)
S11	H	H	H	L	H	Current loop gain setting
S12	H	H	H	L	H	
S13	H	H	H	L	H	
S17	H	H	H	H	L	Current limit setting
S18	H	H	H	H	H	
S19	H	H	H	H	H	

Setting terminal	2-0,1-0,0,5,10,20,30,30R			Remarks
	Pulse coder			
	2000P	2500P	3000P	
S8	L	L	H	Pulse coder F/V gain setting
S9	H	L	L	
S14	L	H	H	Pulse coder pole number, and pulse number setting
S15	H	L	L	
S16	H	L	H	

- Note 1. If either power transformer or regenerative discharge unit is connected across terminals CN2 (4) and (5), set S1 to open (L side). If neither power transformer nor regenerative discharge unit is connected across terminals CN2 (4) and (5), set S1 to short (H side).
- Note 2. Set S2 to open (L side), if the regenerative discharge unit is not mounted, and set it to short (H side), if the regenerative discharge unit is mounted.
- Note 3. Set S10 to L side, if it is needed to check with motor power cable disconnected.
- Note 4. If S20 is set at L side, absolute codes from the pulse coder is output to NC while VRDY is on. If VRDY is turned OFF, the alarm code is output. If S20 is set at H side, the alarm code is always output.
- Note 5. When the absolute value pulse coder is used, set S32 at H side.
- Note 6. If S23 is short-circuited, 7V/2000 rpm will be set. If it is open, 7V/1000 rpm will be set. If models 10, 20, and 30R are used over 1500 rpm, change the above settings and NC parameters (loop gain multipliers).
- Note 7. Models 0, 5, 10, and 20M only may be short-circuited. If S35 and S36 are short-circuited, conversion of current feedback signals (CH10, 11, 12) is 0.183 V/A.
- Note 8. If S37 is short-circuited, the rate feedback voltage is changed from 3V/1000 rpm to 1.5V/1000 rpm. Normally, set it in the open state.
- Note 9. The way of setting is shown as following figures.



(a) Setting of H side



(b) Setting of L side

(2) For Model 4-0, 3-0 (PCB A20B-1000-0590)

Table 3.1.2(e)

Setting terminal	Pulse coder		Remarks
	2000P	2500P	
S1	R		TOH setting (Note 1)
S8	R	OPEN	Pulse coder F/V Gain
S10	L		TG alarm enable (Note 2)
S15	L	L	Pulse coder Pole number, pulse number setting
S16	L	H	
S20	L	L	

- Note 1. If power transformer is connected across terminals CN2 (4) and (5), set S1 to open (R side).  
If power transformer is not connected across terminals CN2 (4) and (5), set S1 to short (L side).
- Note 2. Set S10 to R side, if it is needed to check with motor power cable disconnected.
- Note 3. If the absolute pulse coder is used set S32 at H side.
- Note 4. The way of setting is shown as following figures.

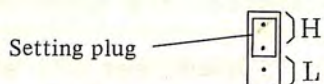

(a) Setting of H side



(b) Setting of L side



(c) Setting of L side



(d) Setting of R side

(3) For Model 5-0

Terminal setting	Standard setting	Remarks
S1	L	TOH setting (Note 1)
S2	L	Pulse coder setting (Note 2)
S3	L	Absolute pulse coder setting (Note 3)
S4	L	TG, OVC alarm disable setting (Note 4)

- Note 1. If the power transformer connected to CN2-(4) and (5), set S1 at L.  
If there is no connection, set S1 at H.
- Note 2. If the pulse coder is 1000P/rev, set S2 at L, and if 2000P/rev, set it at H.
- Note 3. If the absolute pulse coder is used, set S3 at H, and if not used set it at L.
- Note 4. If TG and OVC alarms are made invalid, set S4 at H.
- Note 5. If a 1000P/rev pulse coder is used, care should be taken in DMR setting. (DMR setting should be double that in a normal 2000P/rev pulse coder.)

### 3.1.3 Variable resistor

Table 3.1.3

Volume	Standard setting	Remarks
RV1	40%	Gain setting
RV2	-	Offset voltage adjustment
RV3	-	Tachogenerator voltage adjustment
RV4	-	+5V power supply fine adjustment

Note 1. RV2-RV4 have been adjusted before the shipment from works.

Note 2. RV4 is not employed after edition number F of PCB A20B-1000-0560.



### 3.1.4 Check terminals

Check terminal	Symbol	Description	
CH 1		0.687 x velocity command voltage (Note 1)	
2		0.8 x velocity feedback voltage (Note 2)	
3	OV	OV	
4	OV	OV	
5		Compensation circuit	
6			
7	R	R-phase current command	
8	S	S-phase current command	
9	T	T-phase current command	
10	IR	R-phase current feedback	4V/A for motor 5-0 2.4V/A for motor 4-0, 3-0 0.85V/A for motor 2-0, 1-0 0.25V/A for motor 0,5,10,20M (Note 3)
11	IS	S-phase current feedback	
12	IT	T-phase current feedback	
13	TRW	Traiangle wave (Note 4)	
14	ER	Error voltage (Torque command)	
15	+5V	+5V	
16	+15V	+15V	
17	-15V	-15V	
18	10RF	10V reference voltage	

Note 1. a = 0.344 when VCMD is 7V/1000 rpm

a = 0.687 when VCMD is 7V/2000 rpm

Note 2. Motor Model 4-0 - 30R: 2.4V/1000 rpm

Motor Model 5-0 : 1.2V/1000 rpm

Note 3. 0.183V/A after edition number F of PCB A20B-1000-0560.

Note 4. Triangle wave

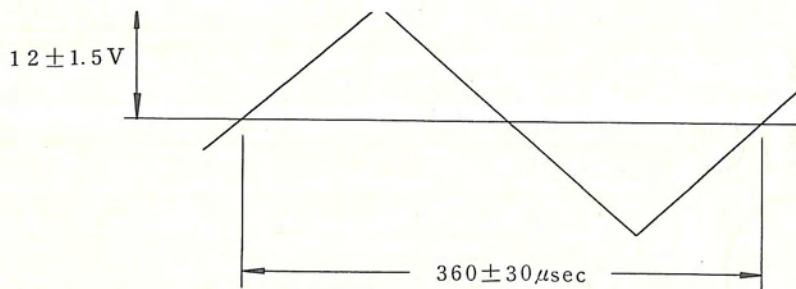

Note 5. Motor load currents (peak values) can be monitored using the same conversion as CH10-12. Effective value can be obtained by multiplying  $1/\sqrt{2}$ .

### 3.2 Block Diagram of Velocity Control Unit

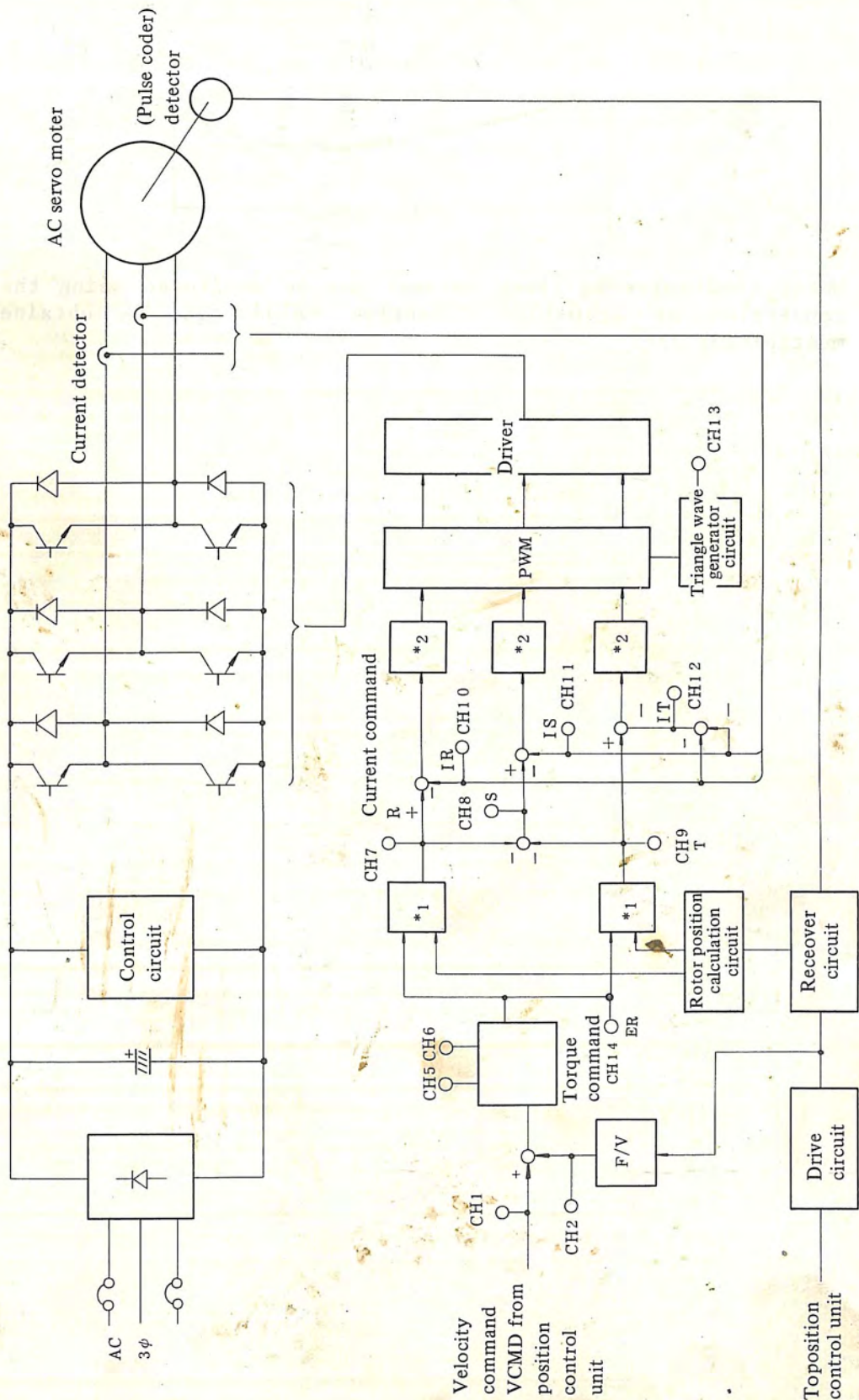

\*1: Multiplication circuit  
 \*2: Amplifier circuit

Fig. 3.2

## 4. TROUBLESHOOTING

### 4.1 Protection and Fault Detecting Functions

The AC servo unit provides the following functions to protect the motor from being overloaded and also detecting abnormal conditions inside the servo loop.

Table 4.1

No.	Kinds of functions	Indications	Description
1	Overload	Contacts' signal comes out at connector CN1	If the temperature of the radiation fin of the unit exceeds the set value to operate the thermostat or if the thermostat of power transformer operates, or if the thermostat of motor operates, this overload alarm is generated.
2	Velocity feedback disconnection detection	Light-emitting diode (LED) TG lights	If the feedback cable is disconnected, TG lamp lights. If a motor does not make a speedy start because of extremely large motor torque, the motor is stopped by dynamic braking with this alarm lamp lit.
3	No-use breaker	On button of NFB is protruded	If an abnormal current exceeding the operating current of no-fuse breaker flows, this NFB operates, causing the motor to be stopped by dynamic braking.
4	High voltage alarm	LED HV lights	If the DC voltage of the main power supply is abnormally high, the motor is stopped by dynamic braking with HV lamp lit.
5	Low voltage alarm	LED LV lights	If control voltage is abnormally low, or if the fuse for +5V on the PCB has blown out, the motor is stopped by dynamic braking with LV lamp lit.
6	Circuit fault Detection	LED HC lights	If abnormal current flows to the main circuit, the motor is stopped by dynamic braking with HC lamp lit.
		LED DC lights	If the regenerative discharge circuit becomes defective, the motor is stopped by dynamic braking with DC lamp lit. If the acceleration/ deceleration rate is too high, DC lights.
7	Overcurrent alarm	LEC OVC lights	If current exceeding specified value is continuously applied longer than a certain time, the motor is stopped by dynamic braking with OVC lamp lit.

## 4.2 Troubleshooting

Troubleshooting and fault recovery are discussed in this section. The manual should be used to determine the causes of problems.

### (1) Overload alarm

Item	Causes of troubles	Check procedures	Countermeasures
1	PCB setting failure	Check if setting pin S1 of PCB is set as specified.	Set S1 properly.
2	Thermostat of the servo transformer is operating	Remove the wires connected to transformer terminals 51 and 52 and measure the resistance across them. (See section 2.3.2.) The normal value is 10 ohms or less, if the circuit is open (more than 100k $\Omega$ ), the thermostat is operating. If the thermostat is operating and the surface temperature of the transformer is 80 to 90°C, check the motor current during cutting. If the surface temperature is 60° or less, the transformer is defective.	Change the cutting conditions.  Replace the transformer.
3	Radiation fins of the unit are overheated.	Check the motor current.	Change the cutting conditions.
4	Thermostat of the servo motor is operating.	Check the motor current.	Change the cutting conditions.

(2) TG alarm

Item	Causes of troubles	Check procedures	Countermeasures
1	Motor power line is not connected to terminals (5), (6), (7) of terminal board T1 of velocity control unit, or the motor power line is disconnected halfway.	If TG alarm occurs without giving any move command after turning on the power supply, it may possibly be caused by the disconnection failure.	Reconnect power cable.
2	PCB setting failure	Check the set condition according to 3.1.	Change the setting properly.
3	Pulse coder feedback signal is disconnected	Check the feedback cable.	Reconnect the feedback cable.
4 Note	Motor current exceeds the ratings	Check the motor current.	Change the cutting conditions.

Note) OVC alarm is detected after PCB A20B-1000-0560 edition number is d.

(3) Circuit breaker operates

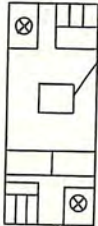
Item	Causes of troubles	Check procedures	Countermeasures
1	Circuit breaker is operating	<p>The operating condition of the circuit breaker is as illustrated below.</p>  <p>This button is protruded forward during operation. Depress this button after turning off the power supply for resetting the circuit breaker.</p>	Reset the circuit breaker after turning off the power supply. (If the circuit breaker cannot be reset soon, wait for about 10 minutes before resetting it).
2	Diode module DS or other parts are defective in velocity control unit	The circuit breaker operates just when turning on the power supply after countermeasure in Item 1.	Replace diode module DS or velocity control unit.
3	Mechanical load is abnormal	Observe PCB CH10, CH11 or CH12-CH3 on an oscilloscope to check if the load current of the motor exceeds the rated current during rapid traverse mode.	Eliminate abnormal load of the machine side.

(4) HV alarm

Item	Causes of troubles	Check procedures	Countermeasures
1	Input AC power voltage is higher than specified	Check if the servo transformer taps are properly connected.	Repair tap connection
2	Servo motor is defective	Check if the insulation resistance is normal between the motor armature (power line) and the body.	Replace motor
3	Load inertia is excessive		Increase the acceleration/ deceleration time constant
4	PCB is defective	HV alarm occurs without any defect in Items 1, 2, 3.	Replace PCB

(5) LV alarm

Item	Causes of troubles	Check procedures	Countermeasures
1	Input AC power voltage is lower than specified	Check if the input AC power voltage and tap connection of servo transformer are correct.	Correct the tap connection
2	Connection failure between servo transformer and PCB CN2	Check if +24V, $\pm 5V$ , and +5V of PCB are normal. Check if servo transformer terminals 41 - 49 (AC 18V) and PCB CN2 (1, 2, 3) are connected properly.	Correct connections
3	Fuse for +5V is blown	check if the fuse for +5V is blown.	Replace the fuse
4	PCB is defective	The LV alarm occurs without any defect in item 1, 2, and 3.	Replace PCB

(6) HC alarm

Item	Causes of troubles	Check procedures	Countermeasures
1	Wrong connection of motor power line	HC alarm does not occur when turning on the power supply after disconnecting the motor power line. (Since the gravity axis may drop in this case, support it or disconnect the drive cable of gravity axis brake)	Reconnect the motor power line correctly. If the motor power line is checked with disconnecting it, set setting terminal S10 to L side, otherwise TG alarm occurs.
2	Transistor module is defective	Check if HC alarm occurs when turning on the power supply after disconnecting the power line according to item 1. Turn off the power supply, remove PCB, and observe the right terminal of the transistor module by a circuit tester. The transistor module is defective, if the resistance between terminals is several $\Omega$ (within $10\Omega$ ).	Replace transistor module. *Check resistance between C1-E1, C2 also between E1, C2-E2. **Check resistance between C1-E1 and also between C2-E2.
3	Internal short-circuit failure of motor windings	Check motor windings for normal insulation.	Replace motor
4	PCB is defective	If HC alarm occurs without any defect in items 1, 2, 3, PCB is defective.	Replace PCB

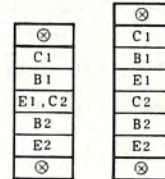



## (7) DC alarm

Item	Causes of troubles	Check procedures	Countermeasures
1	Discharge transistor Q1 is defective or PCB is defective	DC alarm occurs soon after turning on the power supply.	Replace transistor Q1. Replace PCB.
2	PCB setting is improper	Setting terminal S2 is set to L side although the separate regenerative discharge unit is used.	Set S2 properly
3	Frequent acceleration/ deceleration	Check if the positioning frequency exceeds 1 - 2 times/sec at high speed. In this case, DC alarm will not occur when the positioning frequency is reduced.	Decrease the acceleration/ deceleration frequency by providing the dwell

## (8) Servo ready signal is not output

Item	Causes of troubles	Check procedures	Countermeasures
1	AC 100V is not supplied to velocity control unit	Check if AC 100V is supplied across terminals No. (3) and (4) of terminal board T1 of velocity control unit.	Check the emergency stop button on the operation panel
2	The velocity control unit is in alarm status	Check if red alarm LED indicators light on PCB or not.	For countermeasures against these alarms, see (2), (4)-(7)
3	PCB control power voltage +5V or +15V is abnormal	Check the voltage at check terminals CH15, CH16, CH17-CH3 on PCB mounting diagram. Check the connection between servo transformer terminals and PCB CH2.	Change the tap connection of servo transformer. Correct the connection between servo transformer and PCB CH2, and replace PCB.
4	Hybrid IC M2 or relays RLY1, RLY2 of PCB are defective	Check if relays RLY1 and RLY2 are operating.	Replace PCB
5	Circuit breaker off	Check the indicating button circuit breaker.	See (3).

(9) Motor does not rotate when the move command is given.

Item	Causes of troubles	Check procedure	Countermeasures
1	Power line is not connected	TG alarm occurs and the motor does not rotate at all.	Connect the power line properly
2	Enable signal (ENBL1, ENBL2) are not applied to PCB		Check enable signals (ENBL1, ENBL2)
3	PCB is defective or PCB is not properly connected	Check if +24V, +15V, and +5V on PCB are normal.	Replace PCB or reconnect the cable properly
4	Velocity command voltage (VCMD) is not applied	Observe PCB CH1 (VCMD)-CH3 (GND) on an oscilloscope.	Give the velocity command voltage (VCMD)

(10) OVC alarm

(This protection is applied from edition number C of velocity control PCB A20B-1000-0560.)

Item	Causes of troubles	Check procedure	Countermeasures
1	Feedback signal of pulse coder is not connected	Check feedback cable connection.	Connect the feedback cable
2	Motor current exceed nominal value	Check motor current.	Change the cutting condition

## 5. PARTS SPECIFICATIONS AND LOCATIONS ON VELOCITY UNIT

### 5.1 Model 5-0 Velocity Control Unit (A06B-6050-H301)

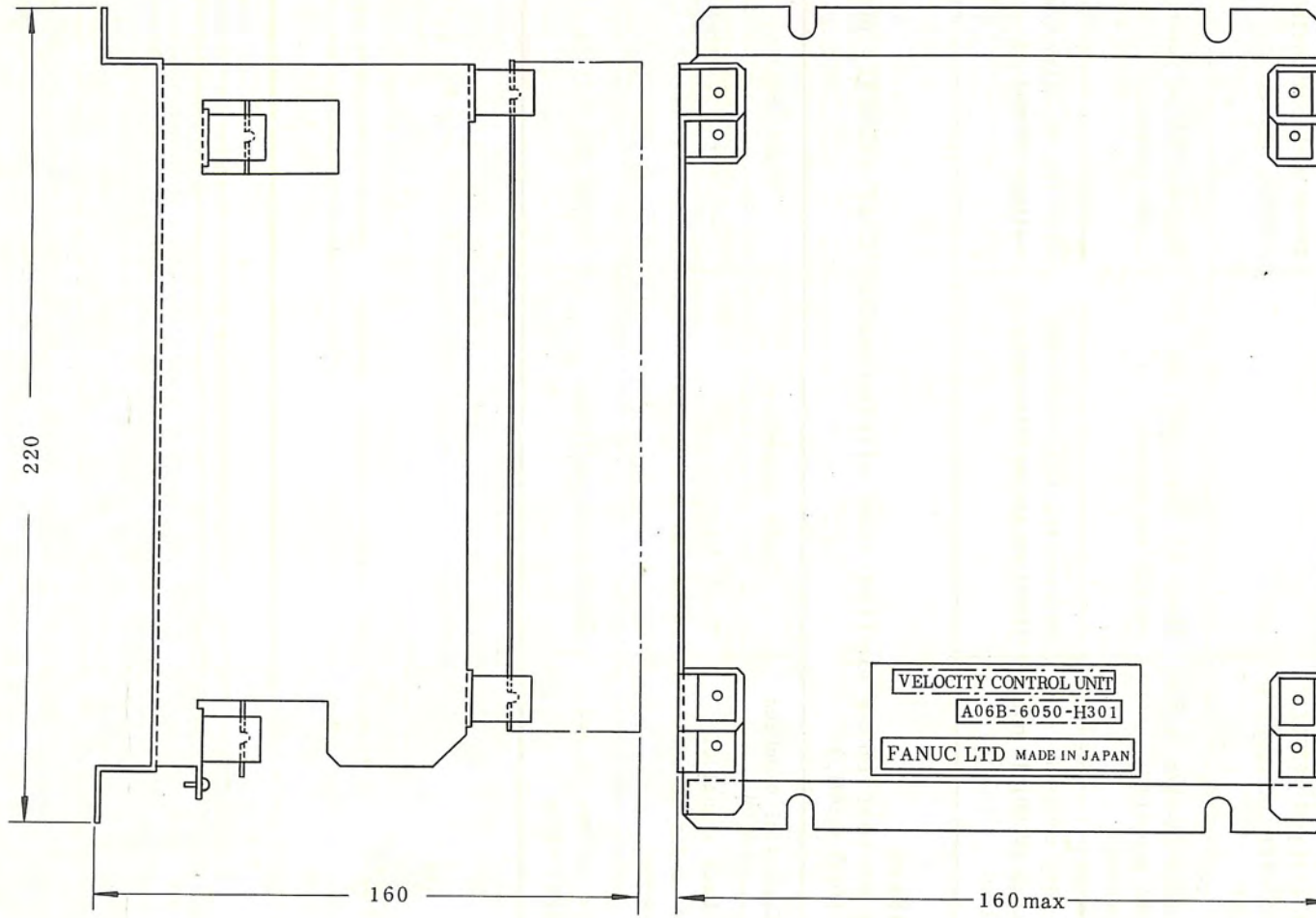

Fig. 5.1

5.2 Model 4-0, 3-0 Velocity Control Unit (A06B-6050-H001)

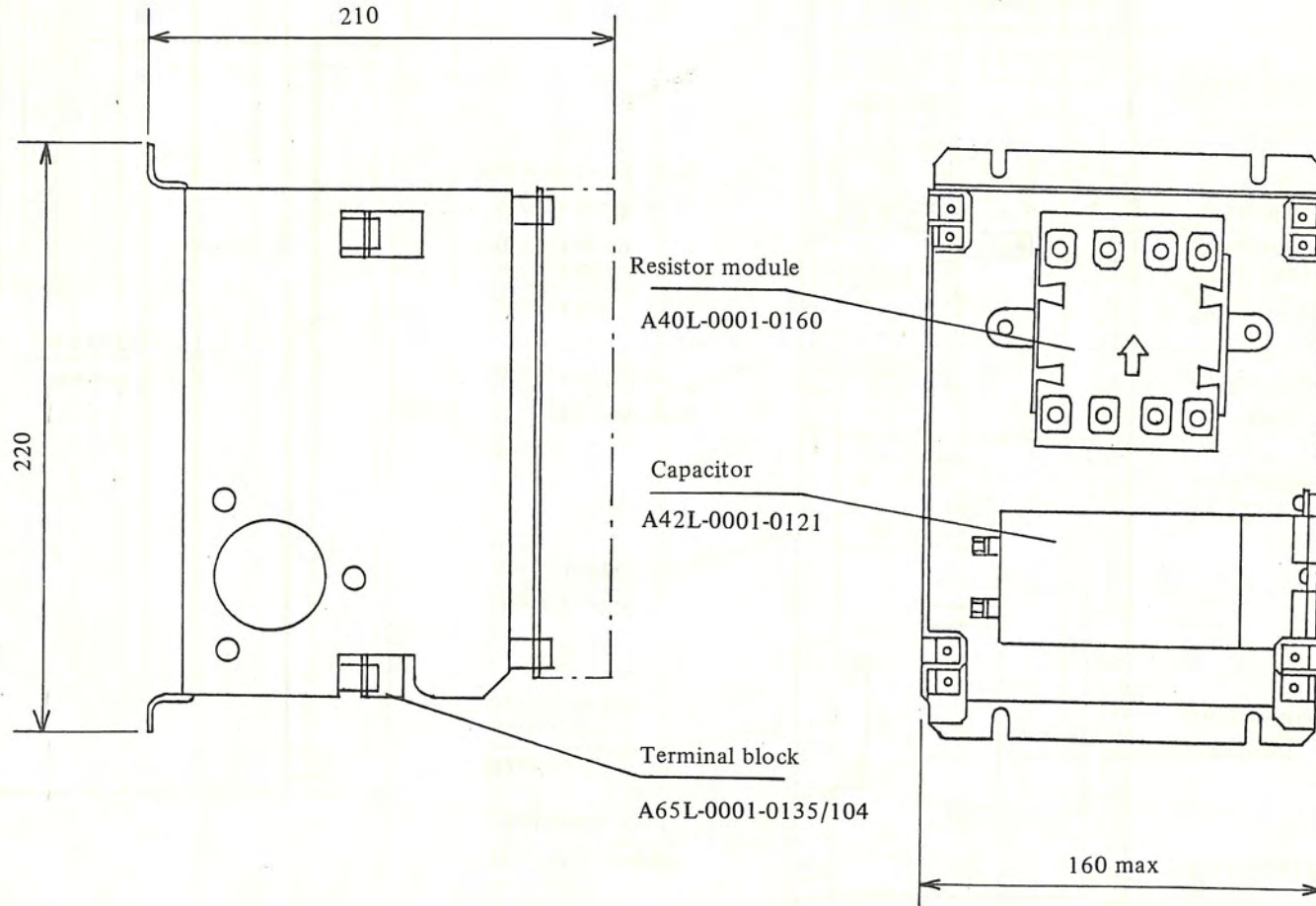

Fig. 5.2

5.3 Model 2-0, 1-0, Velocity Unit (A06B-6050-H002)

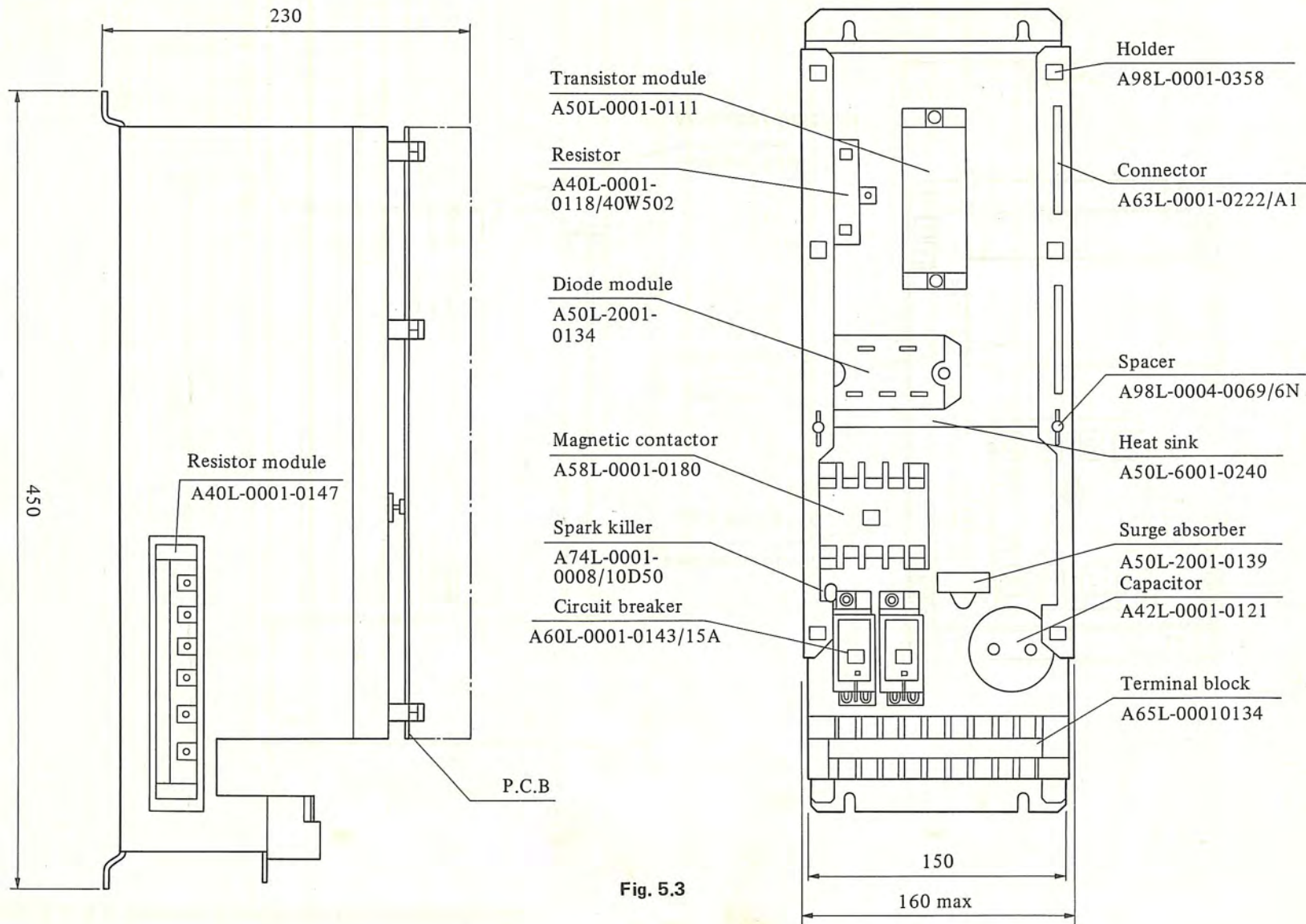

Fig. 5.3

# 5.4 Model 0, 5 Velocity Unit (A06B-6050-H102)

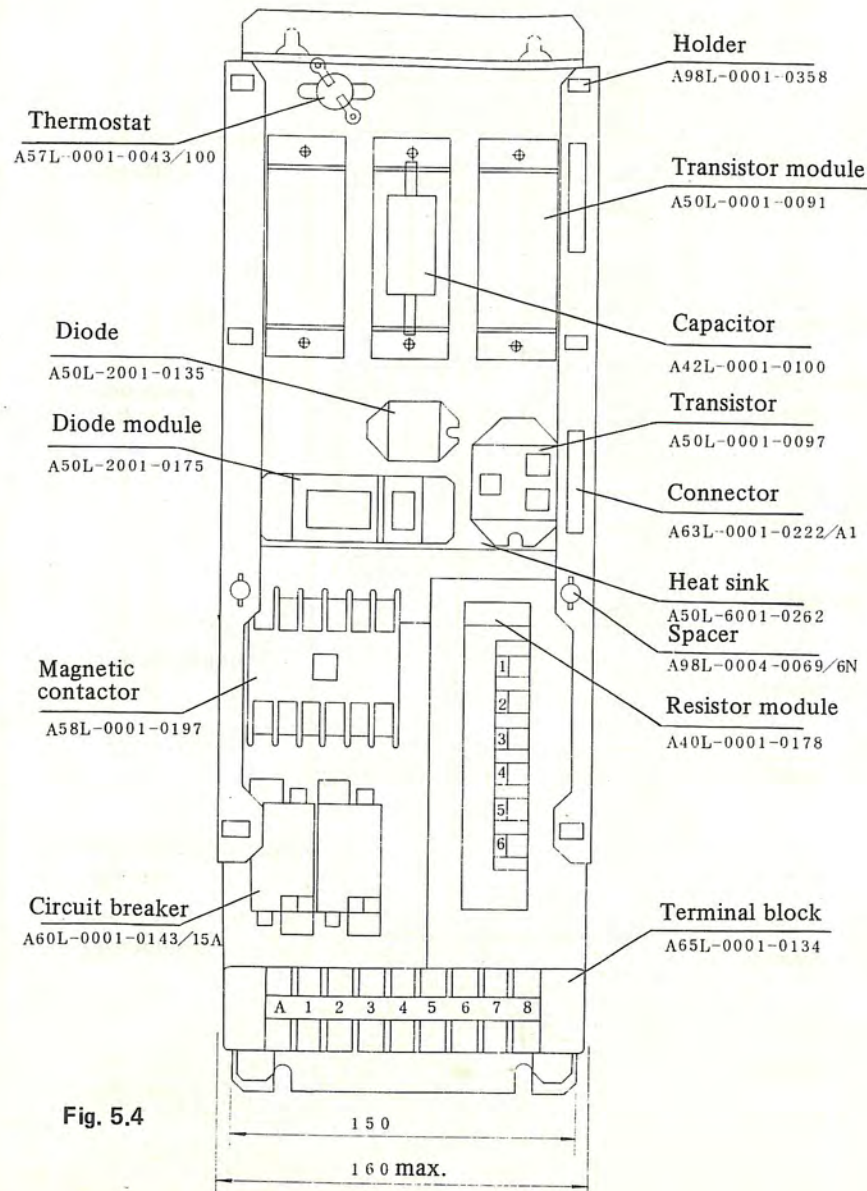
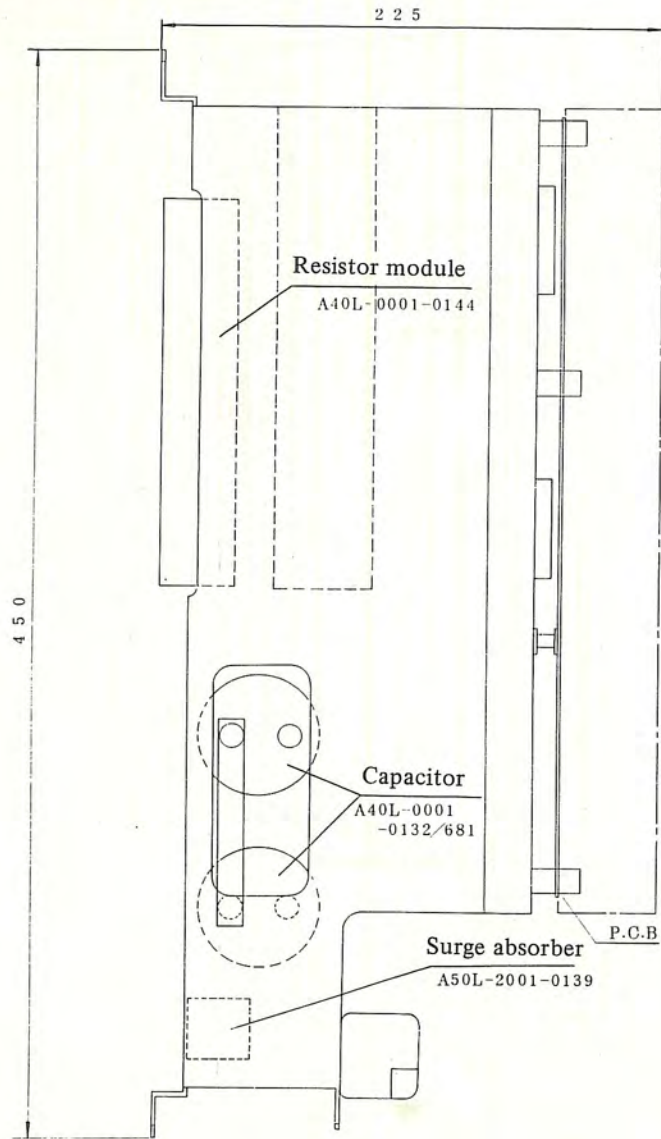

Fig. 5.4

### 5.5 Model 10 Velocity Unit (A06B-6050-H103)

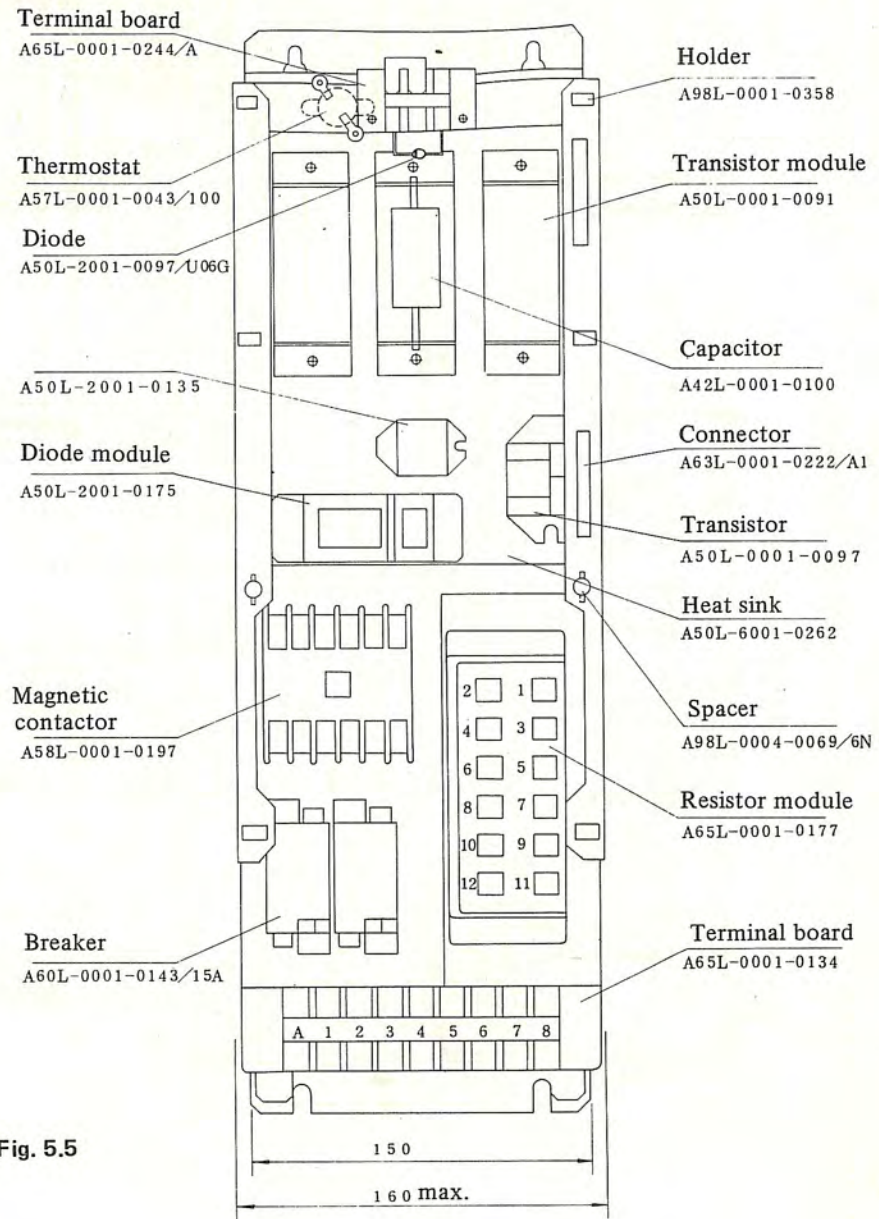
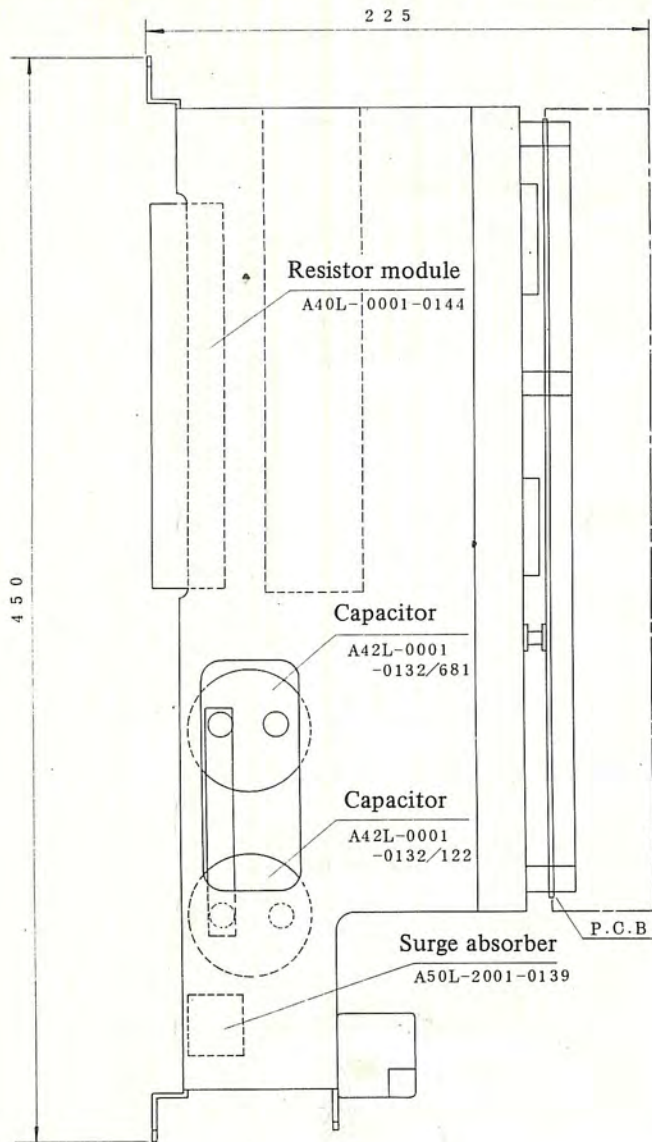

Fig. 5.5

### 5.6 Model 20M Velocity Unit (A06B-6050-H113)

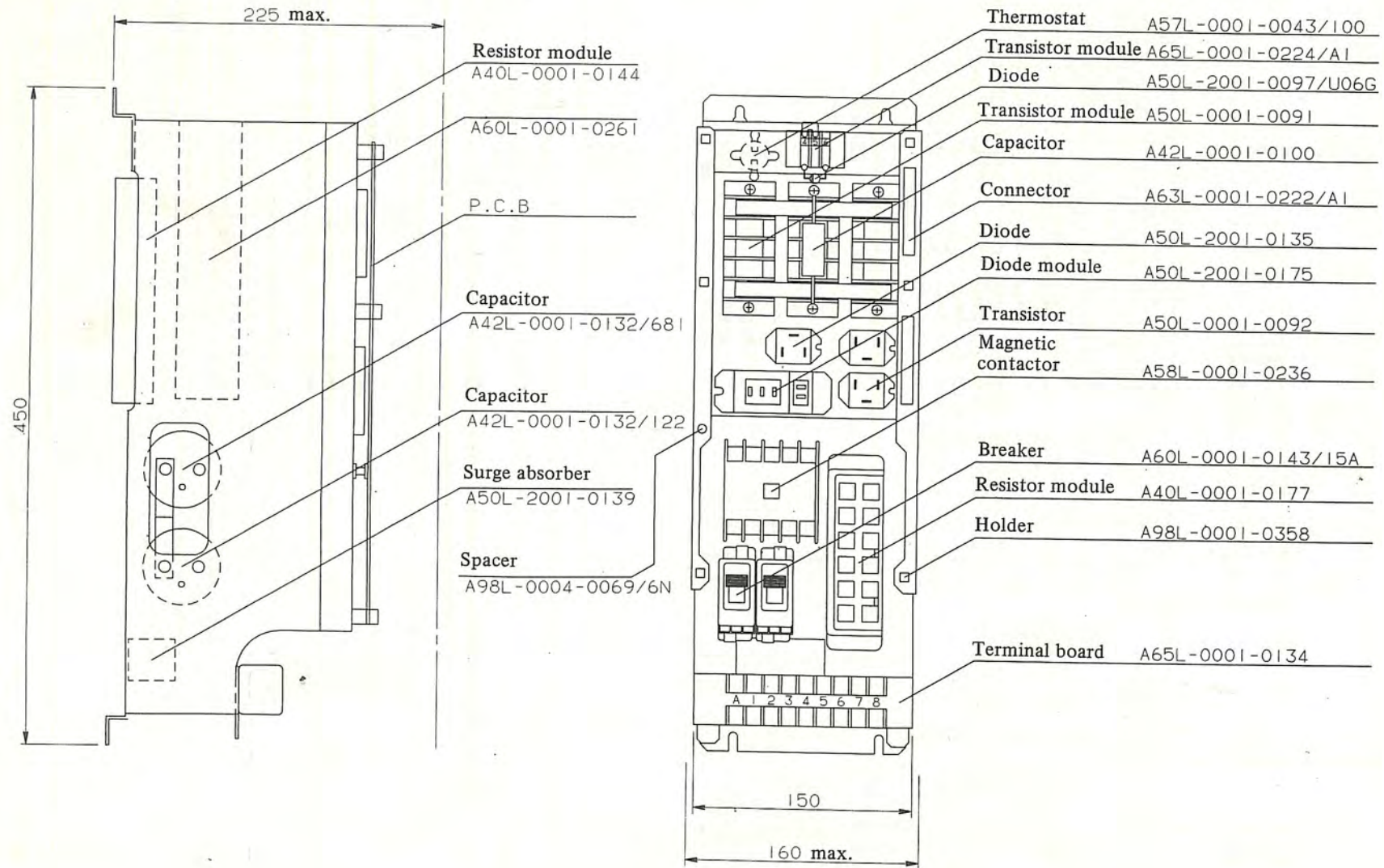

Fig. 5.6



5.7 Model 20, 30 Velocity Unit (A06B-6050-H104) *VIC.7*

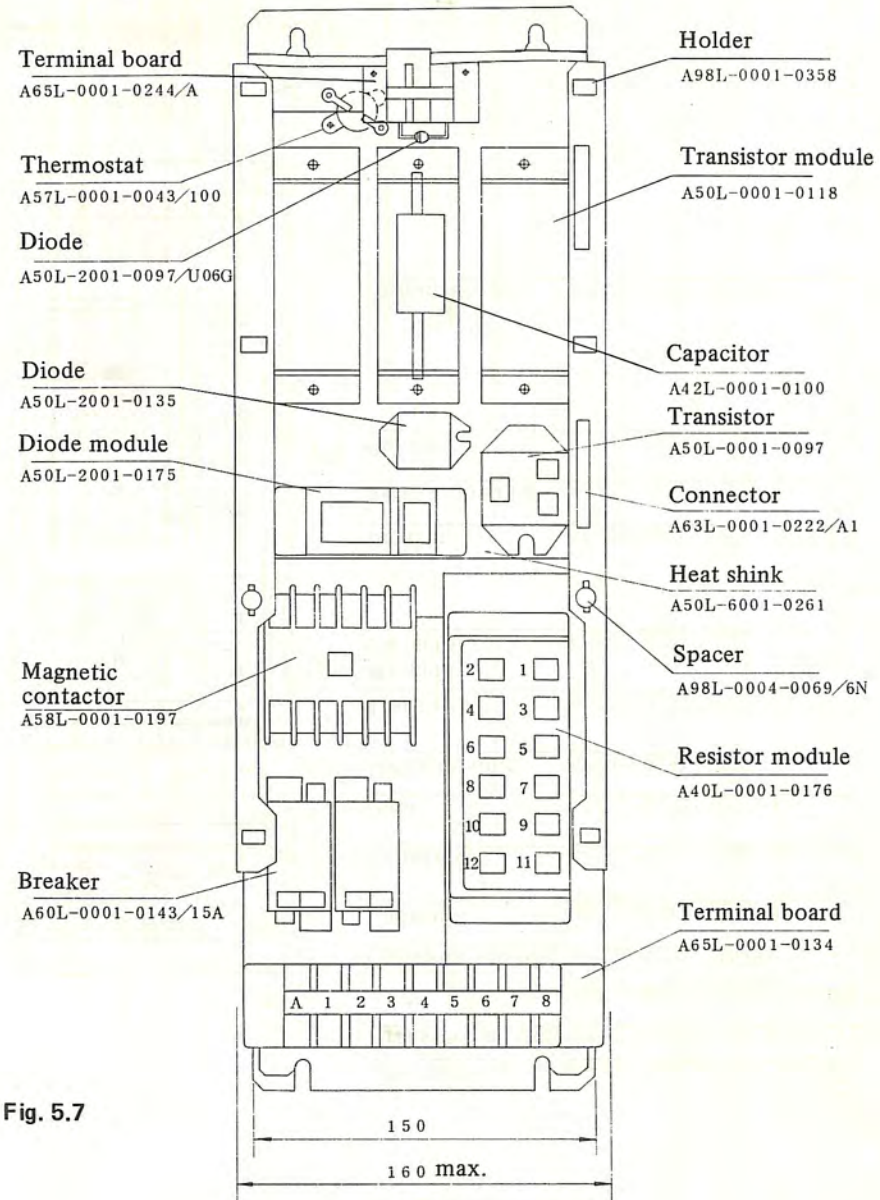
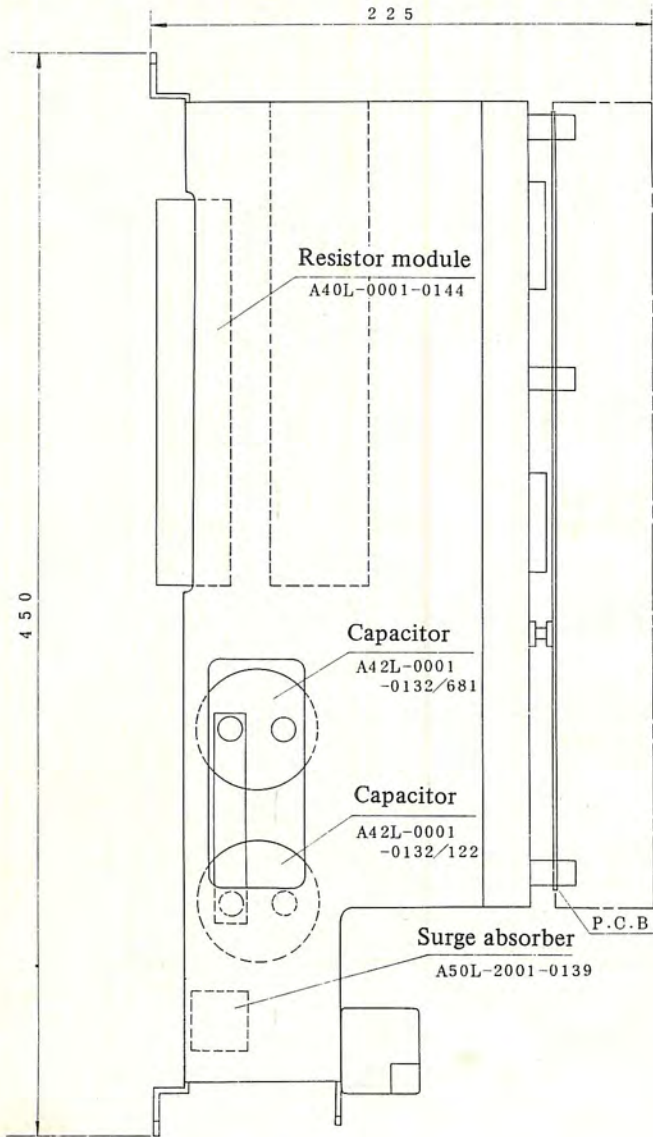

Fig. 5.7

### 5.8 Model 30R Velocity Unit (A06B-6050-H0050)

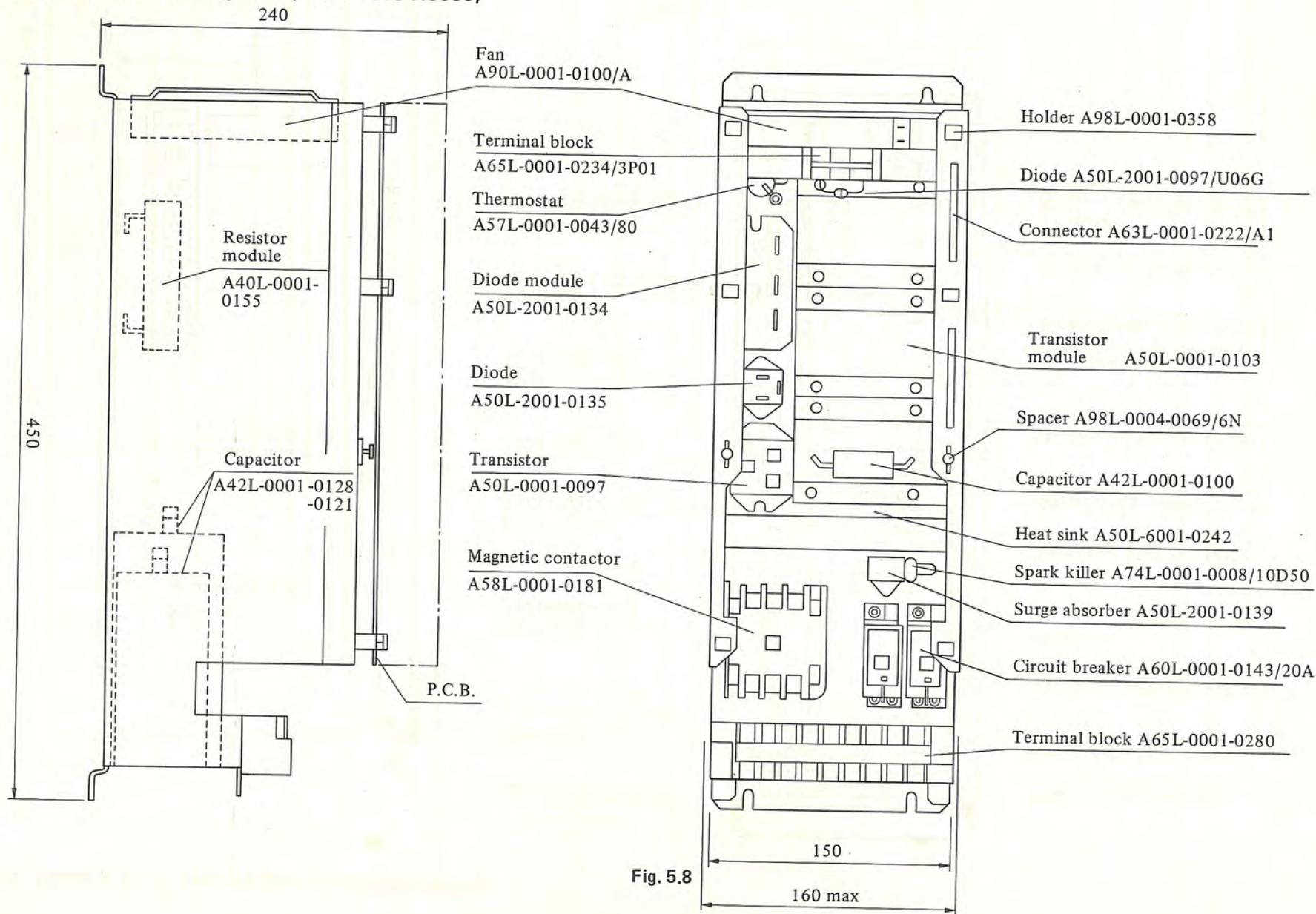

Fig. 5.8

### 5.9 Model 0, 5, 10 Velocity Unit (A06B-6050-M003)

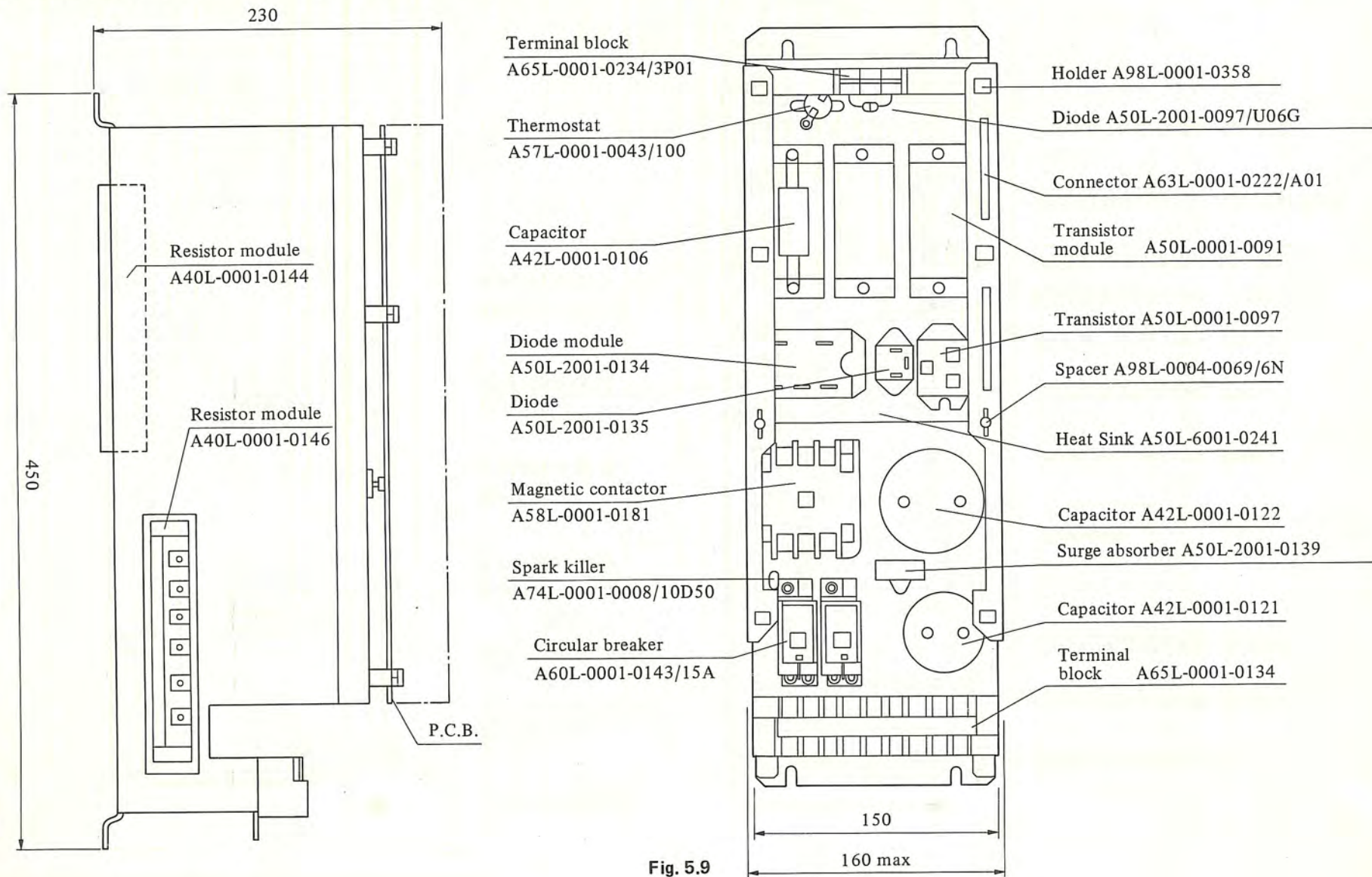
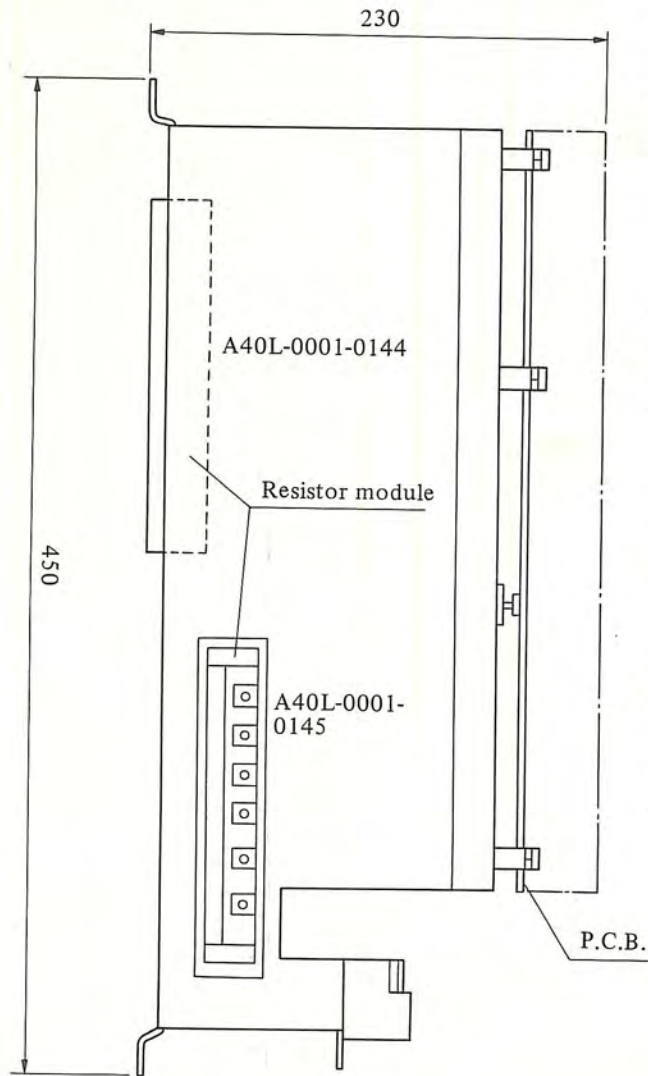

Fig. 5.9

5.10 Model 20, 30 Velocity Unit (A06B-6050-H004)



- Terminal block  
A65L-0001-0234/3P01
- Thermostat  
A57L-0001-0043/100
- Diode module  
A50L-2001-0134
- Diode  
A50L-2001-0135
- Transistor  
A50L-0001-0097
- Magnetic contactor  
A58L-0001-0181
- Spark killer  
A74L-0001-0008/10D50
- Circuit breaker  
A60L-0001-0143/15A

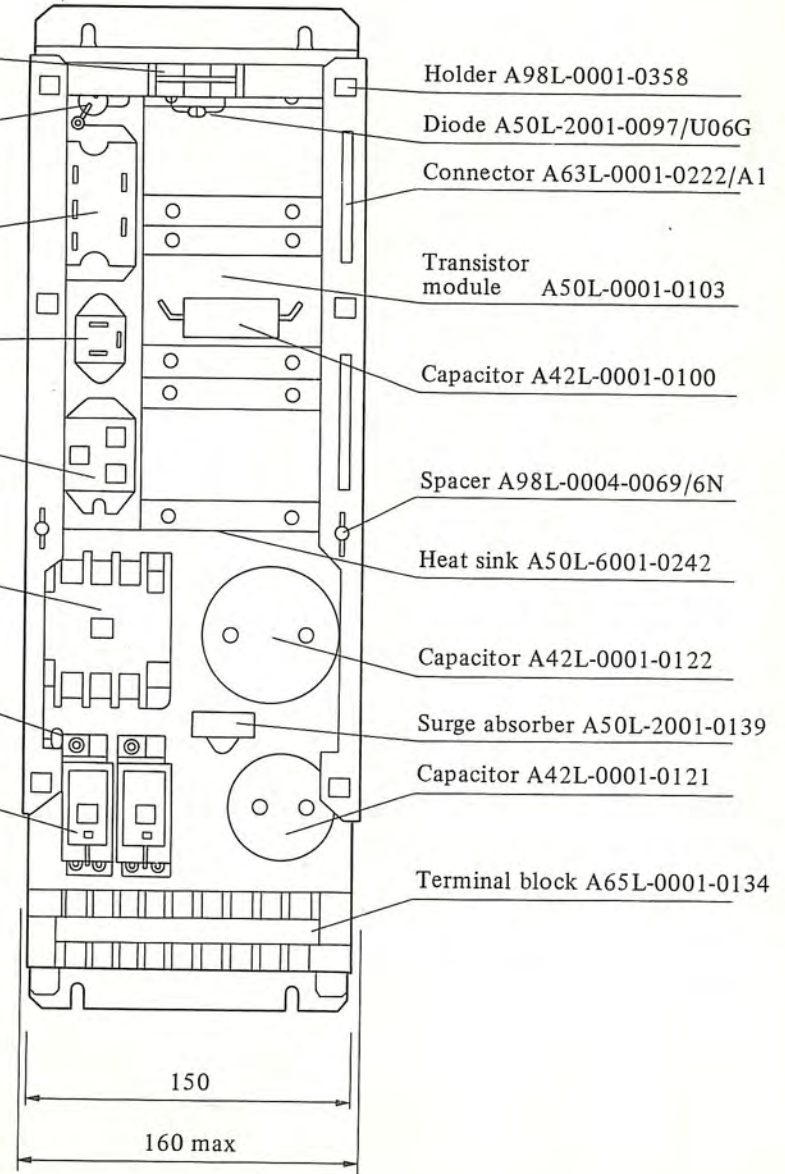

Fig. 5.10

## II. AC SERVO UNIT FOR 2 AXES

This chapter describes the maintenance of AC servo unit for 2 axes which drives AC servo motor Model 2-0, 1-0, 0, 5.

Combination of two motors are described in Table 1.1.1. Refer to Table 1.1.1.

## 1. STRUCTURE

The AC servo unit for 2 axes consists of the velocity control unit and power transformer. Three types of velocity control units are available according to the combinations of AC servo motor models employed. One velocity control unit applies to two servo motors. The specifications of the power transformer are the same as those of a power transformer employed when two servo units for one axis are used according to the combinations of motor models.

Fig. 1.1 shows a configuration example in an NC system of 2 controlled axes.

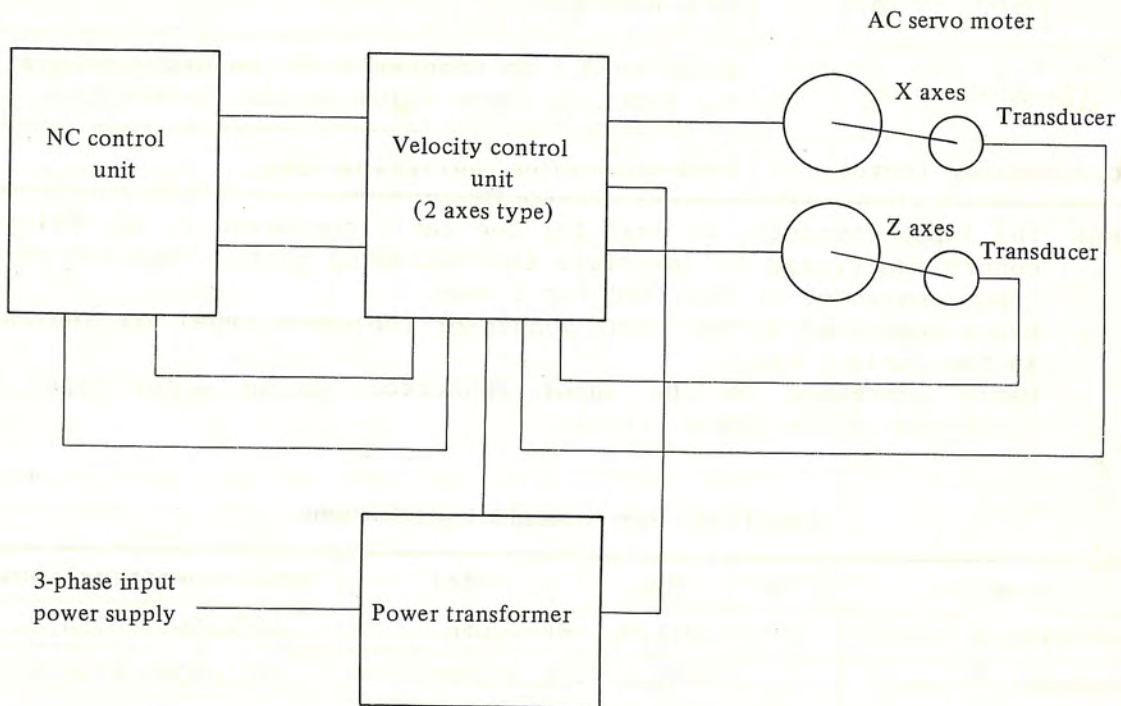

Fig. 1 A Configuration Example of Using AC Servo Unit for 2 Axes

## 1.1 Types of Units and Designated Specifications

Table 1.1 (a) Types of Units and Designated Specifications

Name	Applicable motor		Specifications	Remarks
	L axis	M axis		
Velocity control unit	2-0/1-0	2-0/1-0	A06B-6050-H201	
	2-0/1-0	0/5	A06B-6050-H202	
	0/5	0/5	A06B-6050-H203	
Power transformer			Refer to 2.1 in Chapter 2 in the descriptions for FANUC AC SERVO MOTOR series (B-54762E).	
Input connector (Note)			A06B-6050-K200 Soldering type	

Note: The input connector is used for the cable connected to the velocity control unit, and it comprises the following parts. One set of the input connector is required for 2 axes. Parts contained in the input connector (soldered type) are indicated in the Table 1.1(b). Parts contained in the input connector (crimp style type) are indicated in the Table 1.1(c).

Table 1.1 (b) Parts Included in Input Connector

Name	Q'ty	Use	Model	FANUC specifications
Connector + cover	2	CN1L,M	MR-20LFH *	A63L-0001-0134/02
Connector + cover	2	CN5L,M	MR-20LWMH *	A63L-0001-0134/15
Connector + cover	2	CN6L,M	MR-20LWFH *	A63L-0001-0134/05
Housing	1	CN2	SMS6PW-5 **	A63L-0001-0202/6W
Pin	5	CN2	RC16M-SCT3 **	A63L-0001-0226

\* Manufacturer: HONDA Tsushin Co., Ltd.  
 \*\* Manufacturer: Burndy Japan Ltd.

Table 1.1 (c) Parts Included in Input Connector (Crimp style type)

Name	Q'ty	Use	Model	FANUC specifications
Connector + cover	2	CN1L,M,N	MR-20L, MRP-20F01 *	A63L-0001-0134/22
Connector + cover	2	CN5L,M,N	MR-20LW, MRP-20M01*	A63L-0001-0134/35
Connector + cover	2	CN6L,M,N	MR-20LW, MRP-20F01*	A63L-0001-0134/25
Contact	80	CN1,6	MRP-F112 *	A63L-0001-0134/F112
Contact	40	CN5	MRP-M112 *	A63L-0001-0134/M112
Housing	1	CN2	SMS6PW-5 **	A63L-0001-0202/6W
Pin	5	CN2	RC16M-S23A **	A63L-0001-0127/S23A

\* Manufacturer: HONDA Tsushin Co., Ltd.  
 \*\* Manufacturer: Burndy Japan Ltd.



## 2. CONNECTIONS

### 2.1 Connection Diagram

Note 1. For details of cables K1 - K7, see 9.1.1 - 9.1.7.

Note 2. Connections of cables K1 and K7 differ according to NC control unit.  
For details, see the connecting manual for each NC.

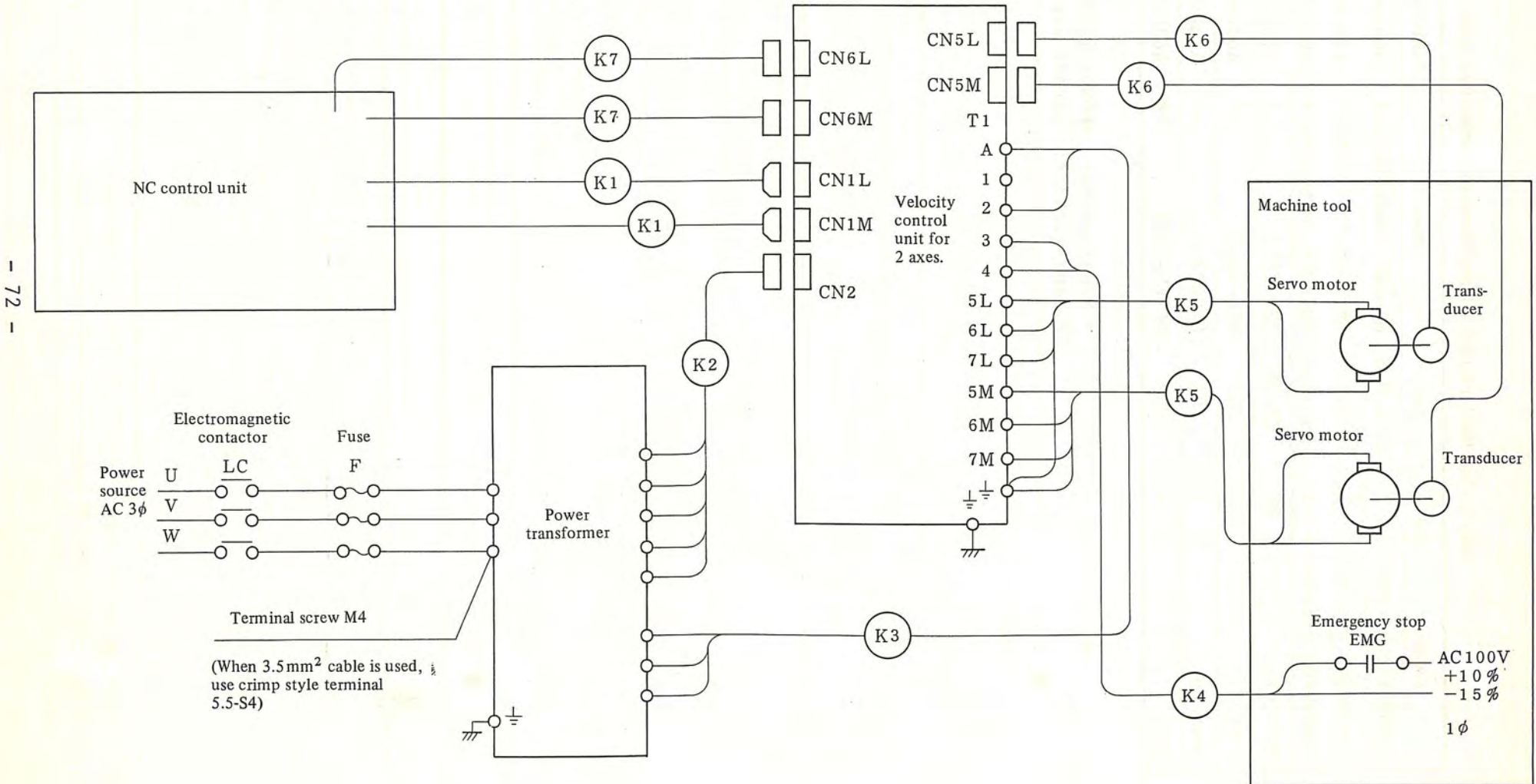

## 2.2 Detailed Servo System Connection Diagram

### 2.2.1 Details of connections of cable K1

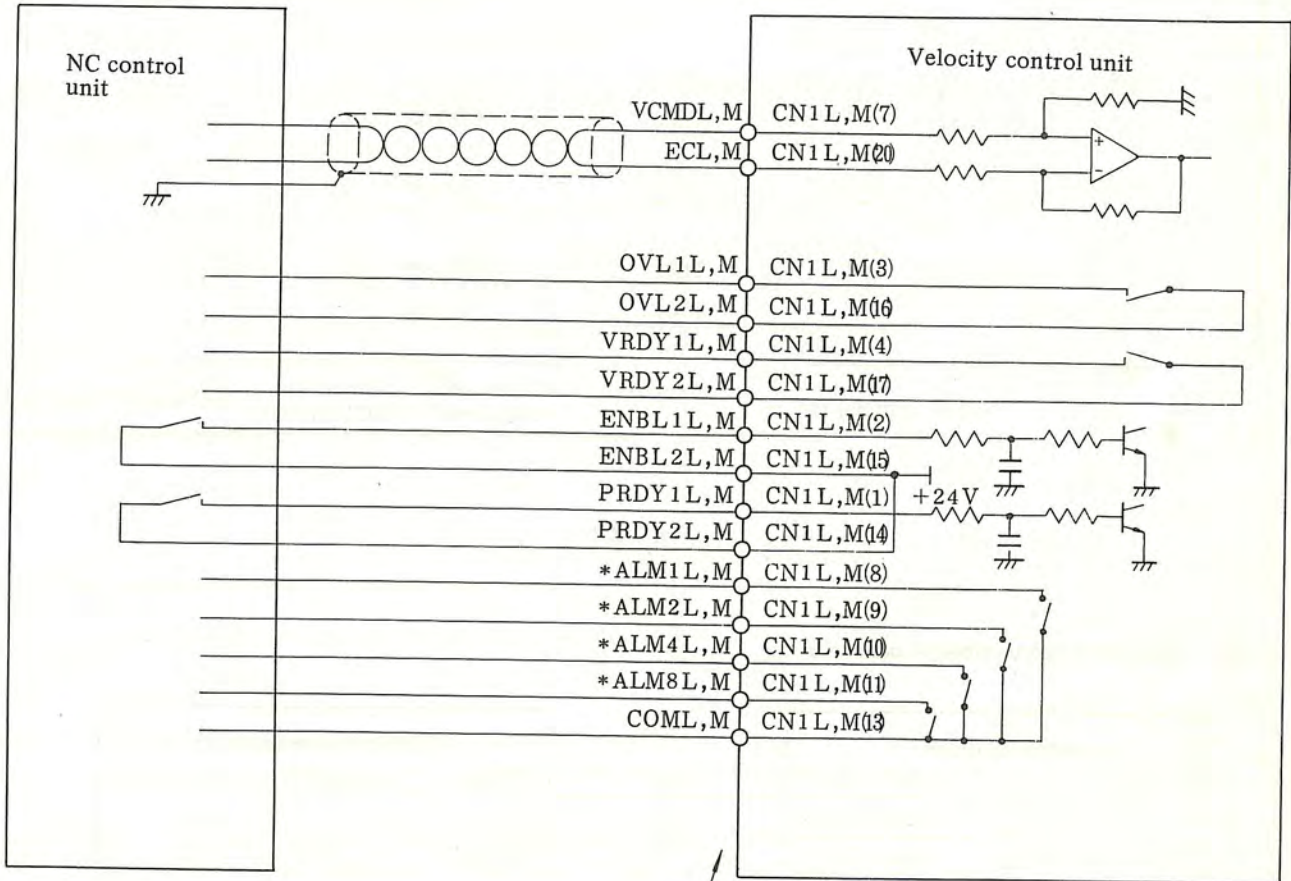

Cable employed:  
 VCMD/EC; 0.1~0.18mm<sup>2</sup> paired shielded cable  
 Other cases; 0.18~0.3mm<sup>2</sup> 200V vinyl wire

Connector MR20LFH (Honda Tsushin Co., Ltd.)  
 (For the connector terminal arrangement, see 8.4)

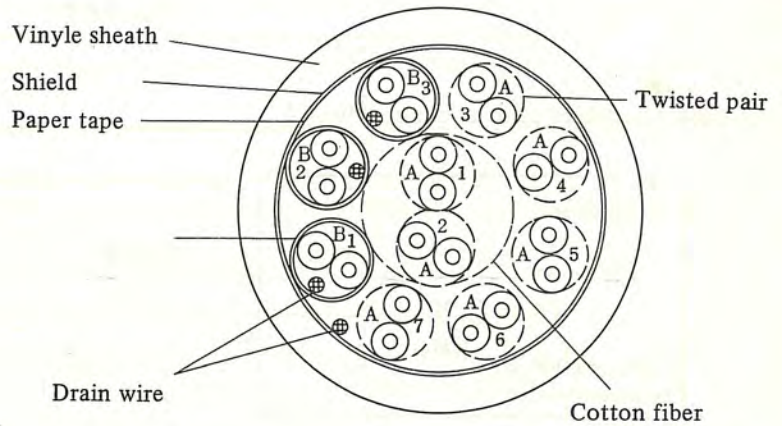

Fig. 2.2.1

### 2.2.2 Details of connections of cable K2

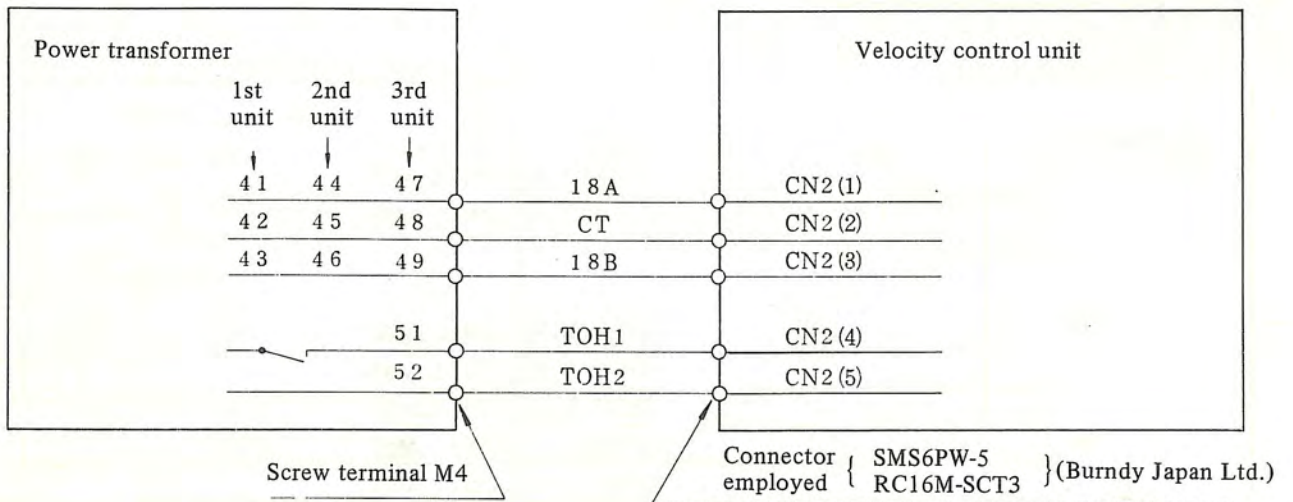
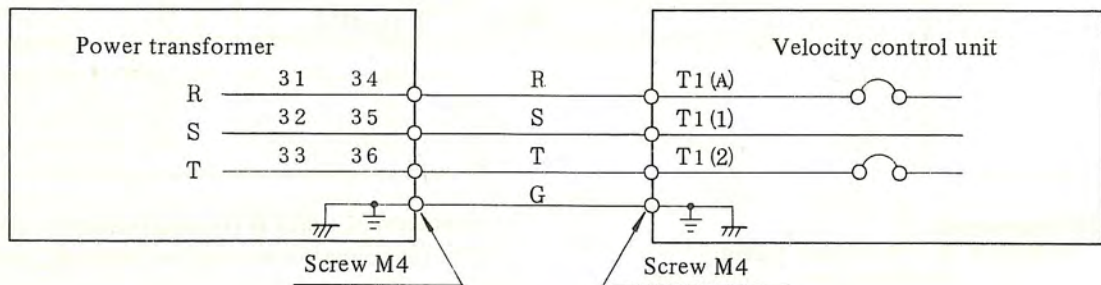

Fig. 2.2.2

### 2.2.3 Details of connections of cable K3



(Cable employed: 2.0 mm<sup>2</sup>, 600V heat-resistive vinyl wire)

Fig. 2.2.3

### 2.2.4 Details of connections of cable K4

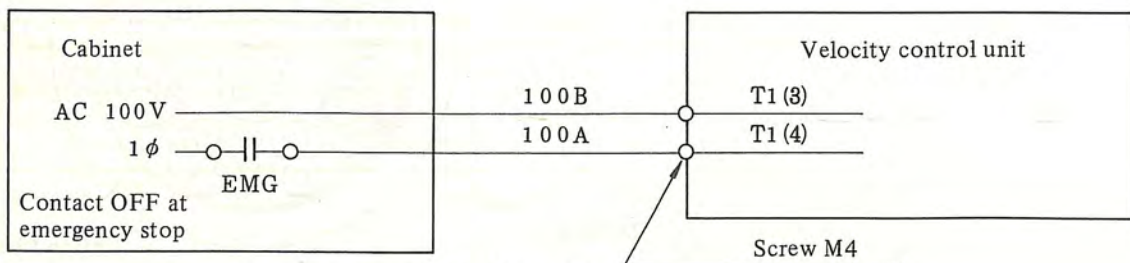

(Cable employed: 0.75 mm<sup>2</sup>, 200V vinyl wire)

Fig. 2.2.4

2.2.5 Details of connections of cable K5

(1) Model 2-0, 1-0

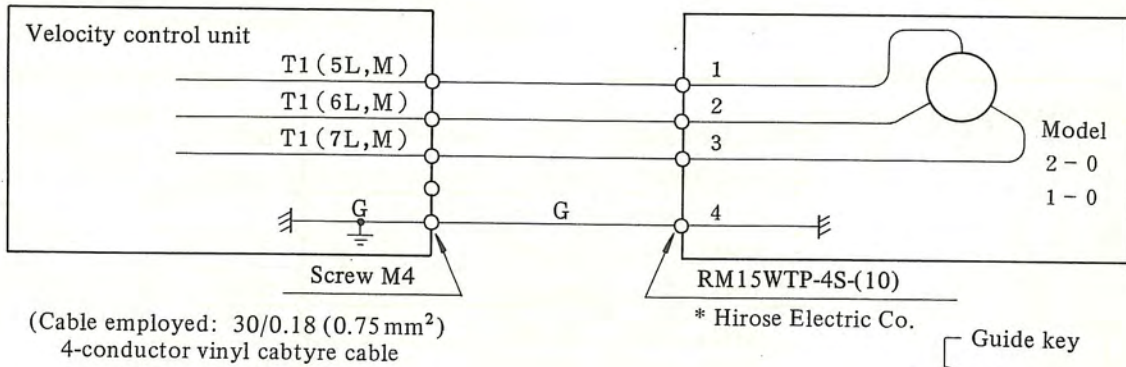

Fig. 2.2.5 (a)

(2) Model 0 and 5

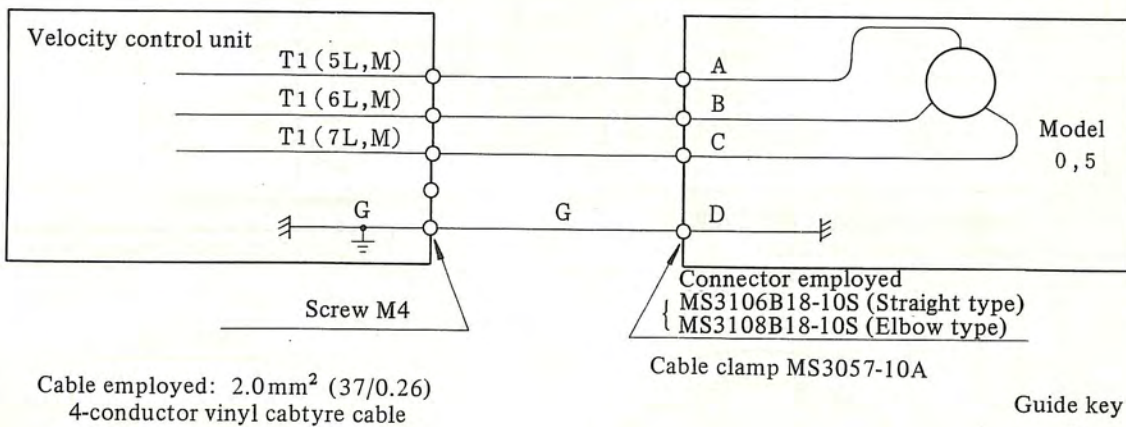

Fig. 2.2.5 (b)

2.2.6 Details of connections of cable K6

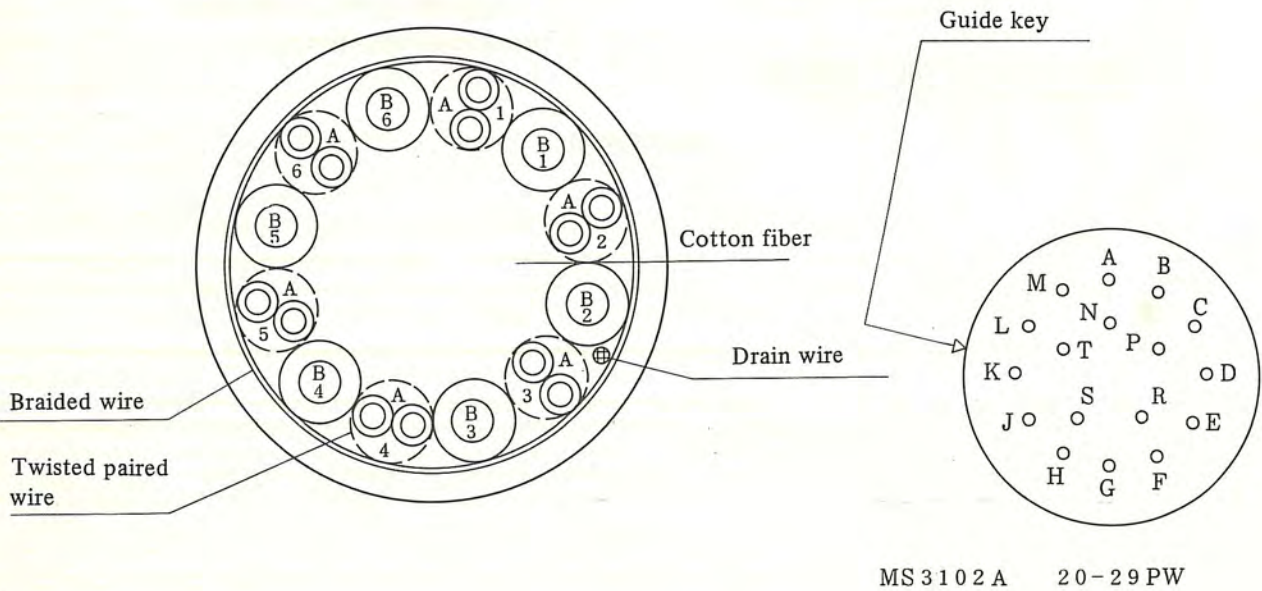
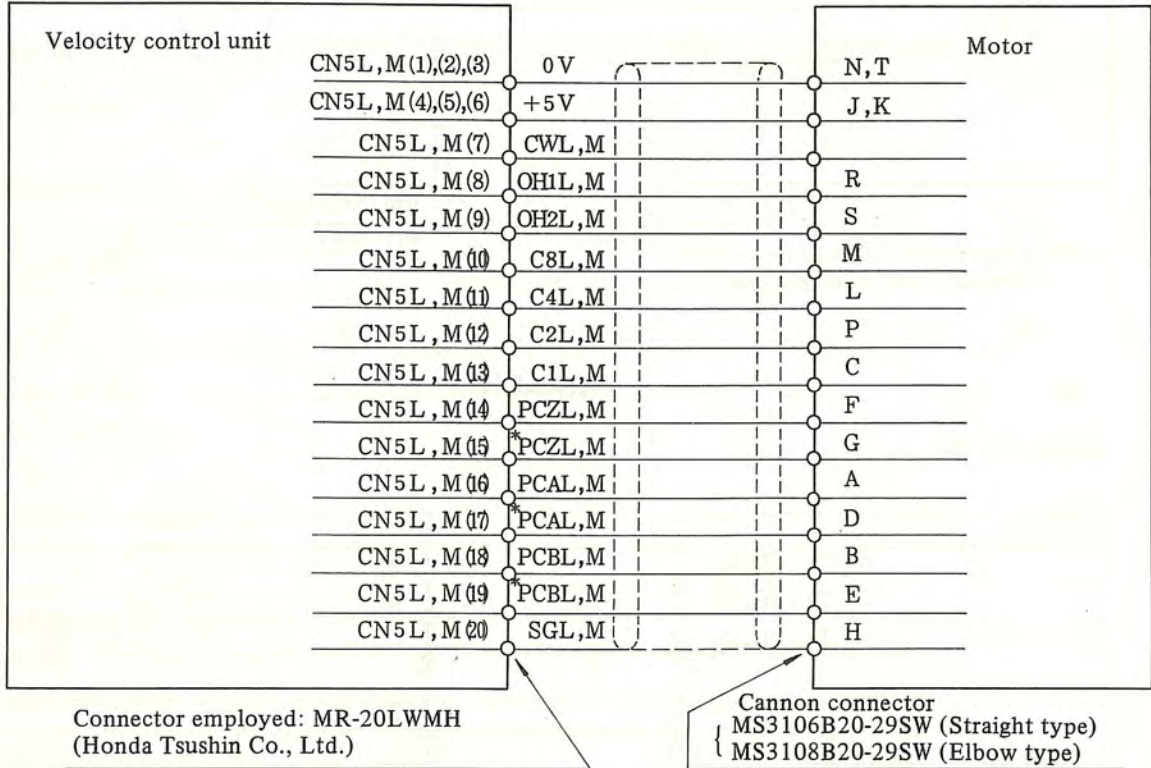

Fig. 2.2.6

### 2.2.7 Details of connections of cable K7

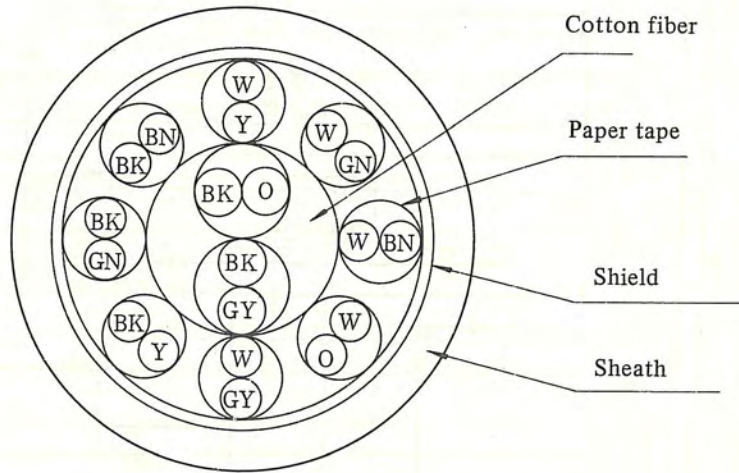
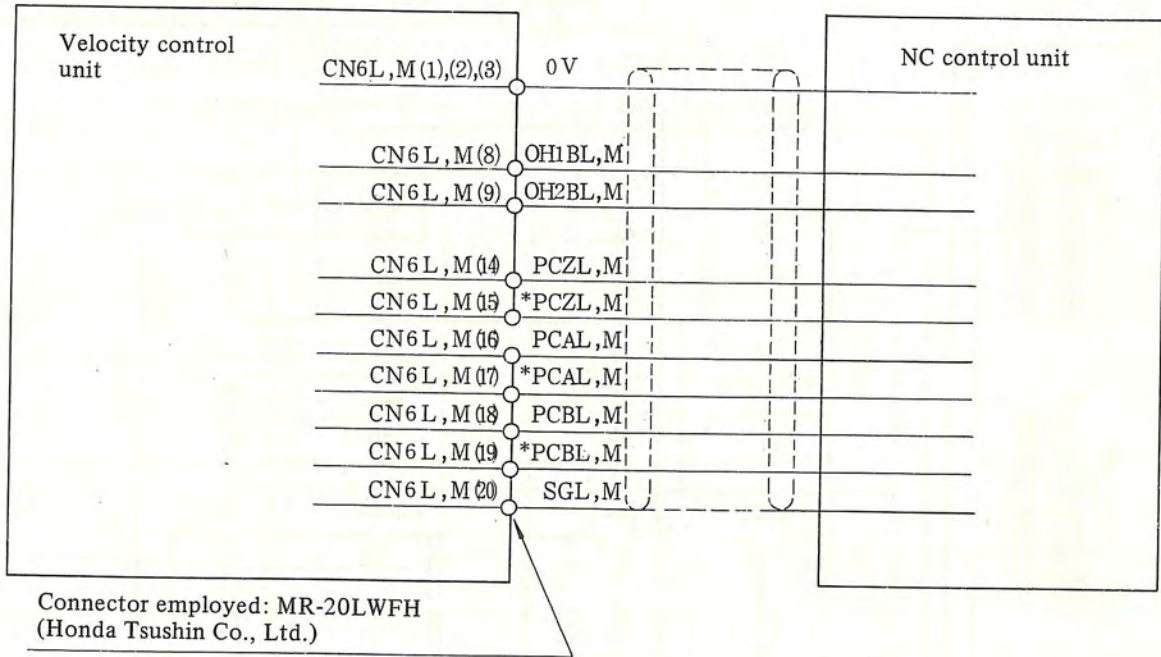

Fig. 2.2.7

### 2.3 Connection of Power Transformer

Refer to the same subsections in Chapter I in this manual.

## 2.4 Connection Diagram of Velocity Control Unit

		H201	H202	H203
RM1	1L-2L, 3L-4L	170mΩ	170mΩ	50mΩ
	5L-6L	400mΩ	400mΩ	120mΩ
	1M-2M, 3M-4M	170mΩ	50mΩ	50mΩ
	5M-6M	400mΩ	120mΩ	120mΩ

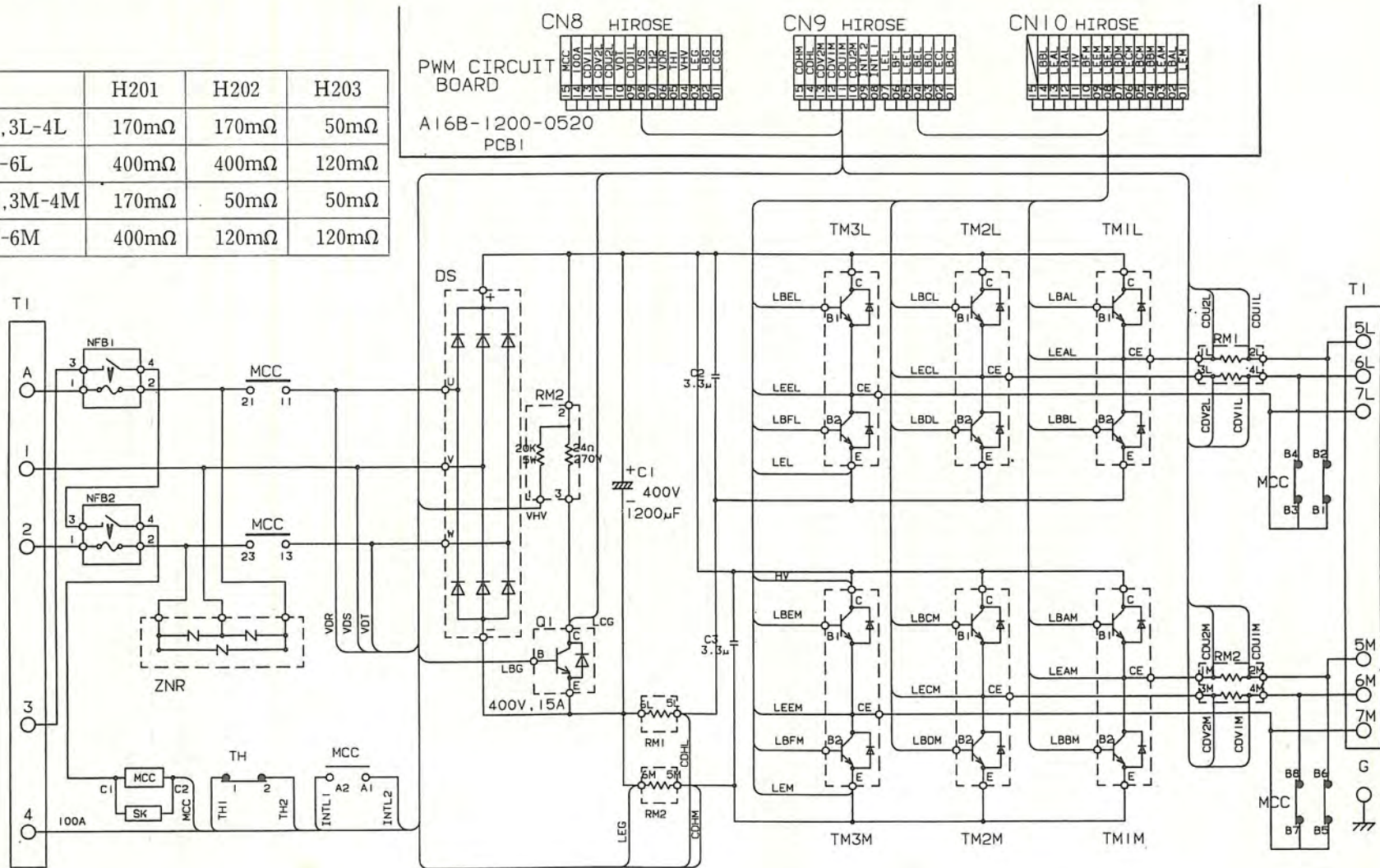

G	H201	AC2-0/1-0 + AC2-0/1-0
○	H202	AC2-0/1-0 + AC0/5
⏏	H203	AC0/5 + AC0/5

CN1L (TO NC.VCMD)

14	PRDY2L	08	ALM1L	01	PROY1L
15	ENBL2L	09	ALM2L	02	ENBL1L
16	OVL2L	10	ALM4L	03	OVL1L
17	VRDY2L	11	ALM6L	04	VRDY1L
18	CLMTL	12		05	CURRL
19		13	COML	06	
20	EL	MR		20P07	VCMDL

CN1M (TO NC.VCMD)

14	PRDY2M	08	ALM1M	01	PROY1M
15	ENBL2M	09	ALM2M	02	ENBL1M
16	OVL2M	10	ALM4M	03	OVL1M
17	VRDY2M	11	ALM8M	04	VRDY1M
18	CLMTM	12		05	CURRM
19		13	COMM	06	
20	EM	MR		20P07	VCMDM

CN5L (TO MOTOR)

01	OV	08	OH1AL	14	PCZL
02	OV	09	OH2AL	15	PCZL
03	OV	10	C8L	16	PCAL
04	+5V	11	C4L	17	PCAL
05	+5V	12	C2L	18	PCBL
06	+5V	13	C1L	19	PCBL
07	CWL	MR		20S20	SGL

CN5M (TO MOTOR)

01	OV	08	OH1AM	14	PCZM
02	OV	09	OH2AM	15	PCZM
03	OV	10	C8M	16	PCAM
04	+5V	11	C4M	17	PCAM
05	+5V	12	C2M	18	PCBM
06	+5V	13	C1M	19	PCBM
07	CWM	MR		20S20	SGM

CN6L (TO NC.PULCO)

14	PCZL	08	OH1BL	01	0V
15	PCZL	09	OH2BL	02	0V
16	PCAL	10		03	0V
17	PCAL	11		04	+5V
18	PCBL	12	CLMT1L	05	+5V
19	PCBL	13	CLMT0L	06	+5V
20	SGL	MR		20P07	CLMT2L

CN6M (TO NC.PULCO)

14	PCZM	08	OH1BM	01	0V
15	PCZM	09	OH2BM	02	0V
16	PCAM	10		03	0V
17	PCAM	11		04	+5V
18	PCBM	12	CLMT1M	05	+5V
19	PCBM	13	CLMT0M	06	+5V
20	SGM	MR		20P07	CLMT2M

A20B-1001-0470  
PCB2

CN7 (TO PCB1)  
YAMAICHI 50P

01A	INTL1	01B	INTL2
02A	OVL1L	02B	OVL2L
03A	OVL1M	03B	OVL2M
04A	IRL	04B	+15V
05A	ISL	05B	+15V
06A	IRM	06B	+15V
07A	ISM	07B	
08A	HVAL1	08B	HVAL2
09A	HVAL1	09B	HVAL2
10A	AL	10B	PRDY
11A	LVAL	11B	DCAL
12A	CLR	12B	+24V
13A	PWFL	13B	+24V
14A	PWFL	14B	+24V
15A	PWDL	15B	-15V
16A	PWCL	16B	-15V
17A	PWBL	17B	-15V
18A	PWAL	18B	+5V
19A	+5V	19B	+5V
20A	PWFM	20B	0V
21A	PWFM	21B	0V
22A	PWDM	22B	0V
23A	PWCM	23B	0V
24A	PWBM	24B	0V
25A	PWAM	25B	

TO POWER  
TRANSFORMER

CN2  
BURNDY

1	18A
2	CT
3	18B
4	TOH1
5	TOH2
6	

A16B-1200-0520  
PCB1

CN7 (TO PCB2)  
YAMAICHI 50P

01A	INTL1	01B	INTL2
02A	OVL1L	02B	OVL2L
03A	OVL1M	03B	OVL2M
04A	IRL	04B	+15V
05A	ISL	05B	+15V
06A	IRM	06B	+15V
07A	ISM	07B	
08A	HVAL1	08B	HVAL2
09A	HVAL1	09B	HVAL2
10A	AL	10B	PRDY
11A	LVAL	11B	DCAL
12A	CLR	12B	+24V
13A	PWFL	13B	+24V
14A	PWFL	14B	+24V
15A	PWDL	15B	-15V
16A	PWCL	16B	-15V
17A	PWBL	17B	-15V
18A	PWAL	18B	+5V
19A	+5V	19B	+5V
20A	PWFM	20B	0V
21A	PWFM	21B	0V
22A	PWDM	22B	0V
23A	PWCM	23B	0V
24A	PWBM	24B	0V
25A	PWAM	25B	

TO NC  
(VCMD)

TO MOTOR  
(PULCO)

TO NC  
(PULCO)



### 3. SETTING AND ADJUSTMENT OF VELOCITY CONTROL UNIT

#### 3.1 Setting and Adjustment of Velocity Control Unit PCB

##### 3.1.1 Parts location

(1) A16B-1200-0520 (Mother board)

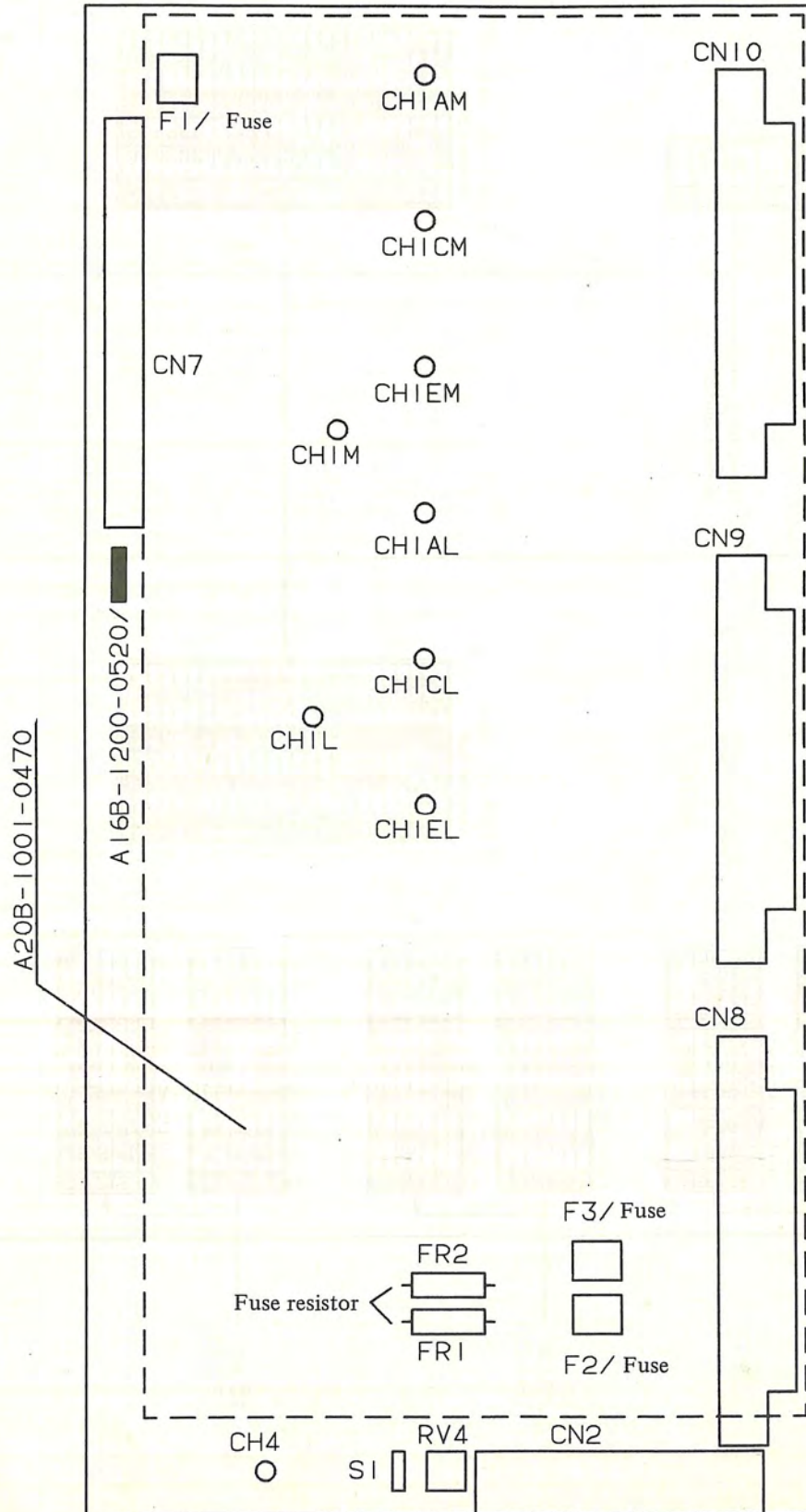

(2) A20B-1001-0470 (Child board)

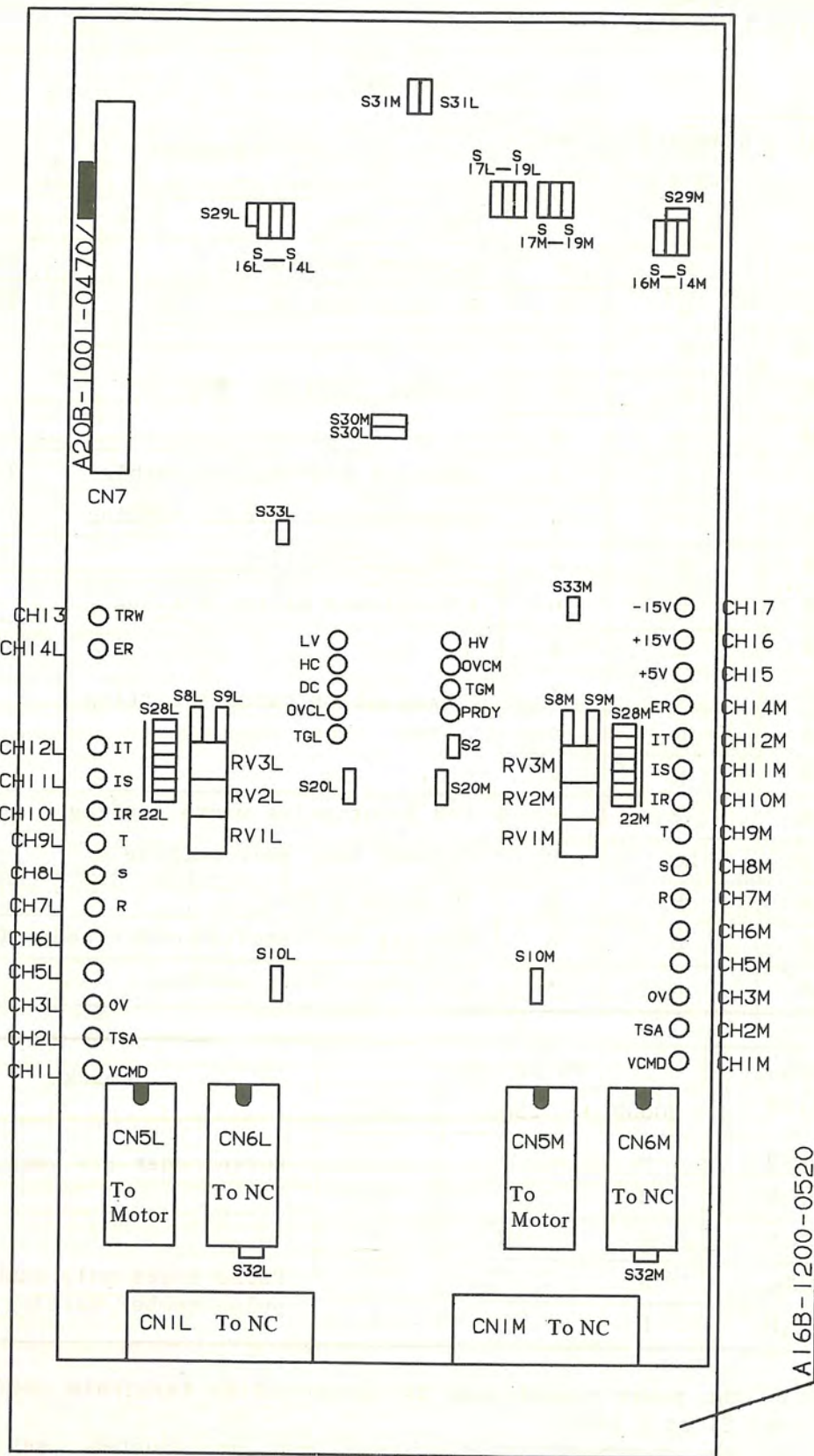

Note 1. Two PCB is 1 sets.

Note 2. Part location on PCB may be changed without notice.

### 3.1.2 Setting terminal

PCB A20B-1001-0470  
A16B-1200-0520

Table 3.1.2

Terminal setting	Standard setting		Remarks
	2-0/1-0	0/5	
S1	L	L	TOH setting (Note 1)
S2	x	x	DC alarm setting (Note 2)
S10L,M	H	H	TG alarm enable (Note 3)
S17L, M	H	H	Current limit setting
S18L,M	H	H	
S19L,M	H	H	
S20L,M	H	H	Absolute code output enable (Note 4)
S22L,M	o	o	Compensation circuit setting
S23L,M	o	o	VCMD gain setting (Note 5)
S24L,M	o	o	F/V circuit filter setting
S25L,M	x	x	Compensation circuit setting
S26L,M	x	x	
S27L,M	o	o	
S28L,M	x	x	
S29L,M	x	x	F/V input pulse width setting (Note 6)
S30L,M	Le	R	Current loop gain setting
S31L,M	H	H	TG alarm enable
S32L,M	o	o	Setting for absolute pulse coder (Note 7)
S33L,M	x	x	OVC alarm level setting

Terminal setting	Pulse coder			Remarks
	2000P	2500P	3000P	
S8L,M	L	L	H	Pulse coder F/V gain setting
S9L,M	H	L	L	
S14L,M	L	H	H	Pulse coder pole number and pulse number setting
S15LM,	H	L	L	
S16L,M	H	L	H	

Note 1. If the power transformer is connected to terminals CN2(4) and (5), set S1 at L side.

Note 2. If the regenerative discharge unit is mounted, set S2 in the short-circuit state. If it is not mounted, set S2 in the open state.

- Note 3. If check is required without connection of the motor power cable, set S10 at L side.
- Note 4. If S20 is set at L side, absolute codes from the pulse coder is output to NC while VRDY is on. If VRDY is turned OFF, the alarm code is output. If S20 is set at H, the alarm code is always output.
- Note 5. If S23 is short-circuited, 7V/2000 rpm is set, and if it is open, 7V/1000 rpm is set.
- Note 6. If S29 is short-circuited, the velocity feedback voltage is changed from 3V/1000 rpm to 1.5V/1000 rpm. Normally, set it in the open state.
- Note 7. If ABS pulse coder is used, set S32 in the open state.
- Note 8. Setting operations are shown in the Fig. below.

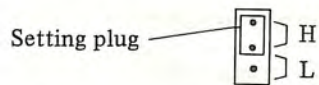

(a) Set at H side



(b) Set at L side



(c) Set at Le side



(d) Set at R side

### 3.1.3 Variable resistor

Table 3.1.3

Volume	Standard setting	Remarks
RV1L, RV1M, RV1N	50%	Gain setting
RV2L, RV2M, RV2N	-	Adjustment of offset voltage
RV3L, RV3M, RV3N	-	Adjustment of velocity feedback voltage

- Note 1. RV2L, M, N and RV3L, M, N are adjusted before shipping from the factory.
- Note 2. Settings of RV1L, M, and L are the same regardless of the number of versions.

### 3.1.4 Check terminals

Table 3.1.4

Check terminal	Symbol	Contents	
CH1L,M	VCMD	a x velocity command voltage	(Note 1)
CH2L,M	TSA	0.8 x velocity feedback voltage	
CH3L,M	0V	0V	
CH4	0V	0V	(Note 2)
CH5L,M		Compensation circuit	
CH6L,M			
CH7L,M	R	R-phase current command	
CH8L,M	S	S-phase current command	
CH9L,M	T	T-phase current command	
CH10L,M	IR	R-phase current feedback	1.18 A/V (Motor 1-0, 2-0)
CH11L,M	IS	S-phase current feedback	
CH12L,M	IT	T-phase current feedback	4.00 A/V (Motor 0, 5)
CH13	TRW	Triangle wave	(Note 3)
CH14L,M	ER	Error voltage (Torque command voltage) (Note 4)	
CH15	+5V	+5V	
CH16	+15V	+15V	
CH17	-15V	-15V	

Note 1. a = 0.344 when VCMD is 7V/1000 rpm

a = 0.687 when VCMD is 7V/2000 rpm

Note 2. Setting terminal S4 is on the PCB A16B-1200-0520.

Note 3. Waveform of triangle wave is as follows.

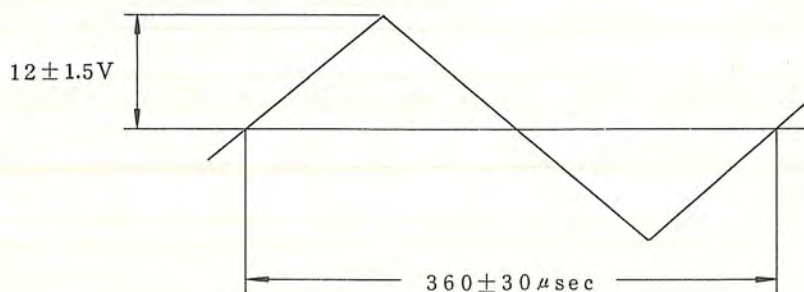

Note 4. Motor load currents (peak values) can be monitored using the same conversion as CH10-12. Effective values can be obtained by multiplying  $1/\sqrt{2}$ .

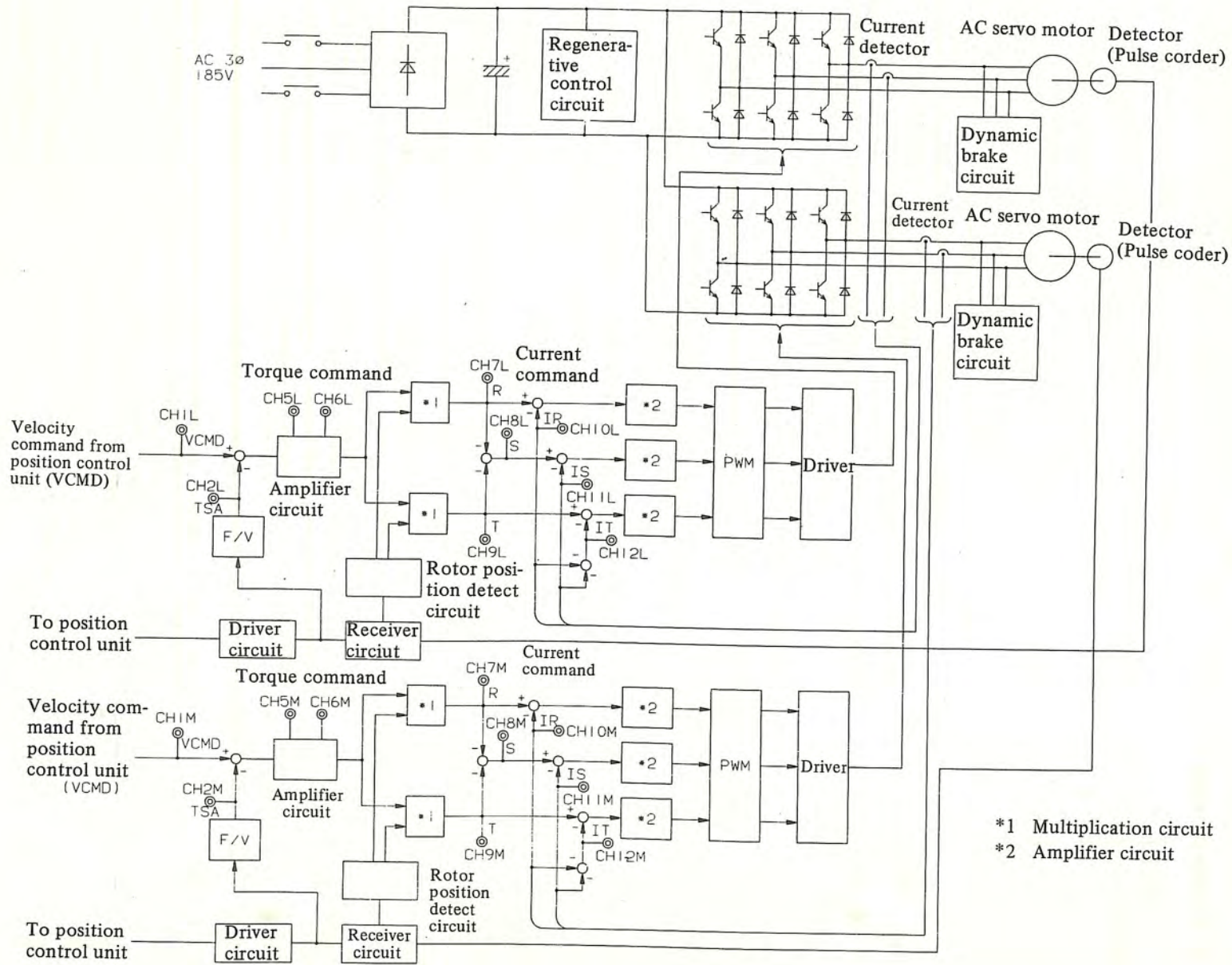

3.2 Block Diagram of Velocity Control Unit

\*1 Multiplication circuit  
\*2 Amplifier circuit

## 4. TROUBLESHOOTING

### 4.1 Protection and Fault Detect Function

### 4.2 Troubleshooting

For subsection 4 - 4.2 refer to the same subsection in Chapter I in this manual.

5. PARTS SPECIFICATION AND LOCATIONS ON VELOCITY UNIT

5.1 Model 1-0/2-0 and Model 1-0/2-0 (A06B-6050-H201)

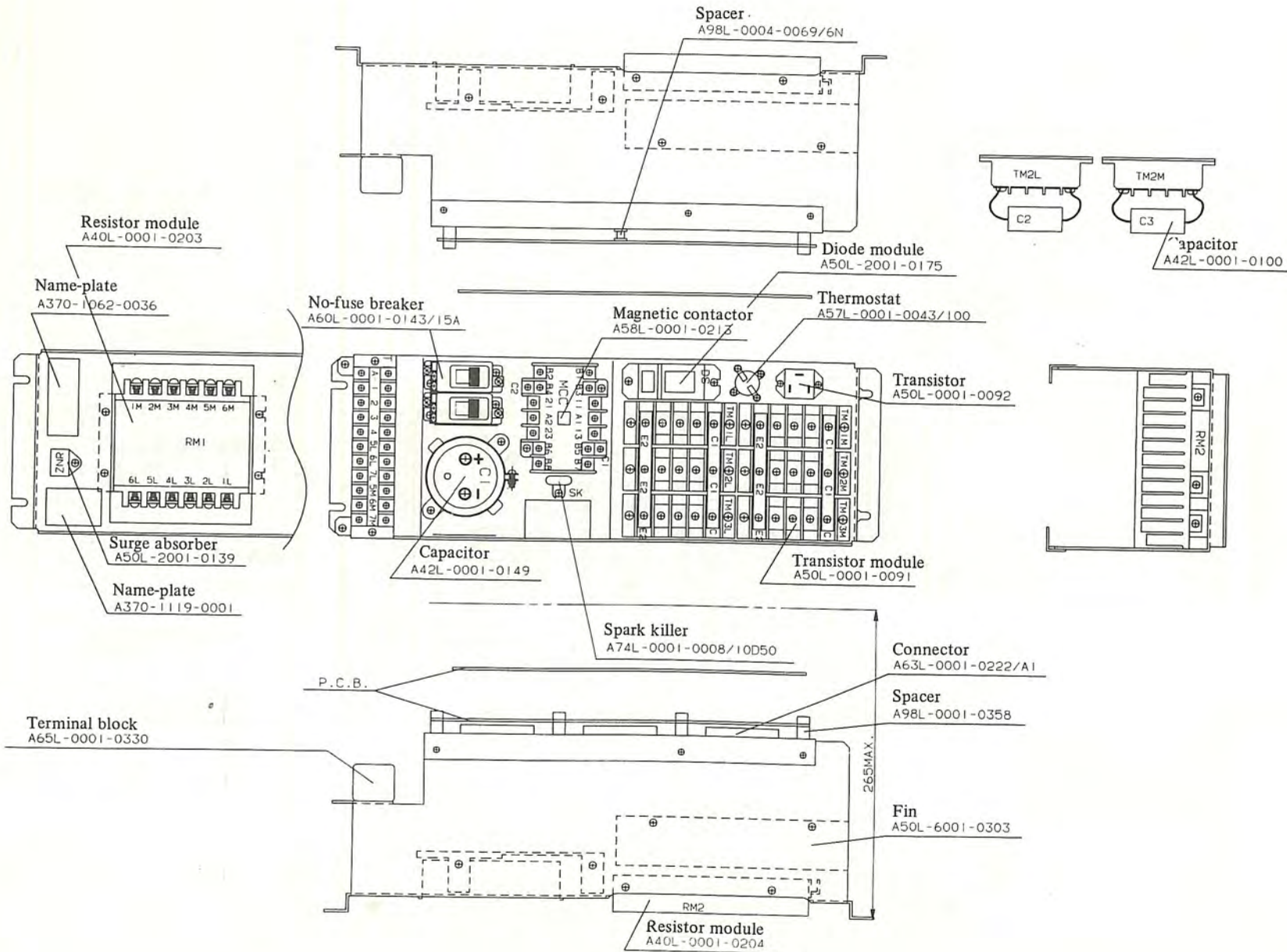



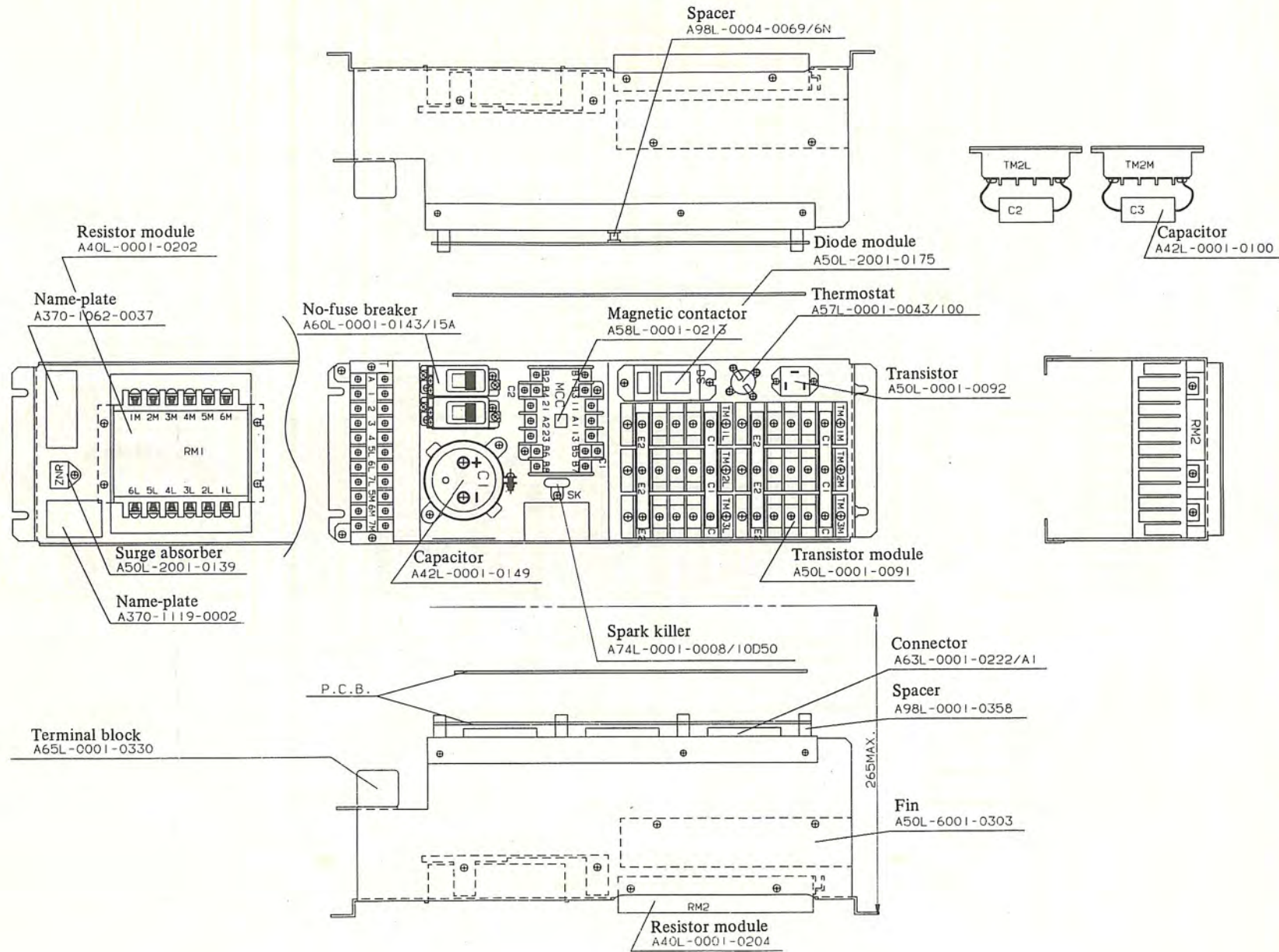

5.3 Model 0/5 and Model 0/5 (A06B-6050-H203)

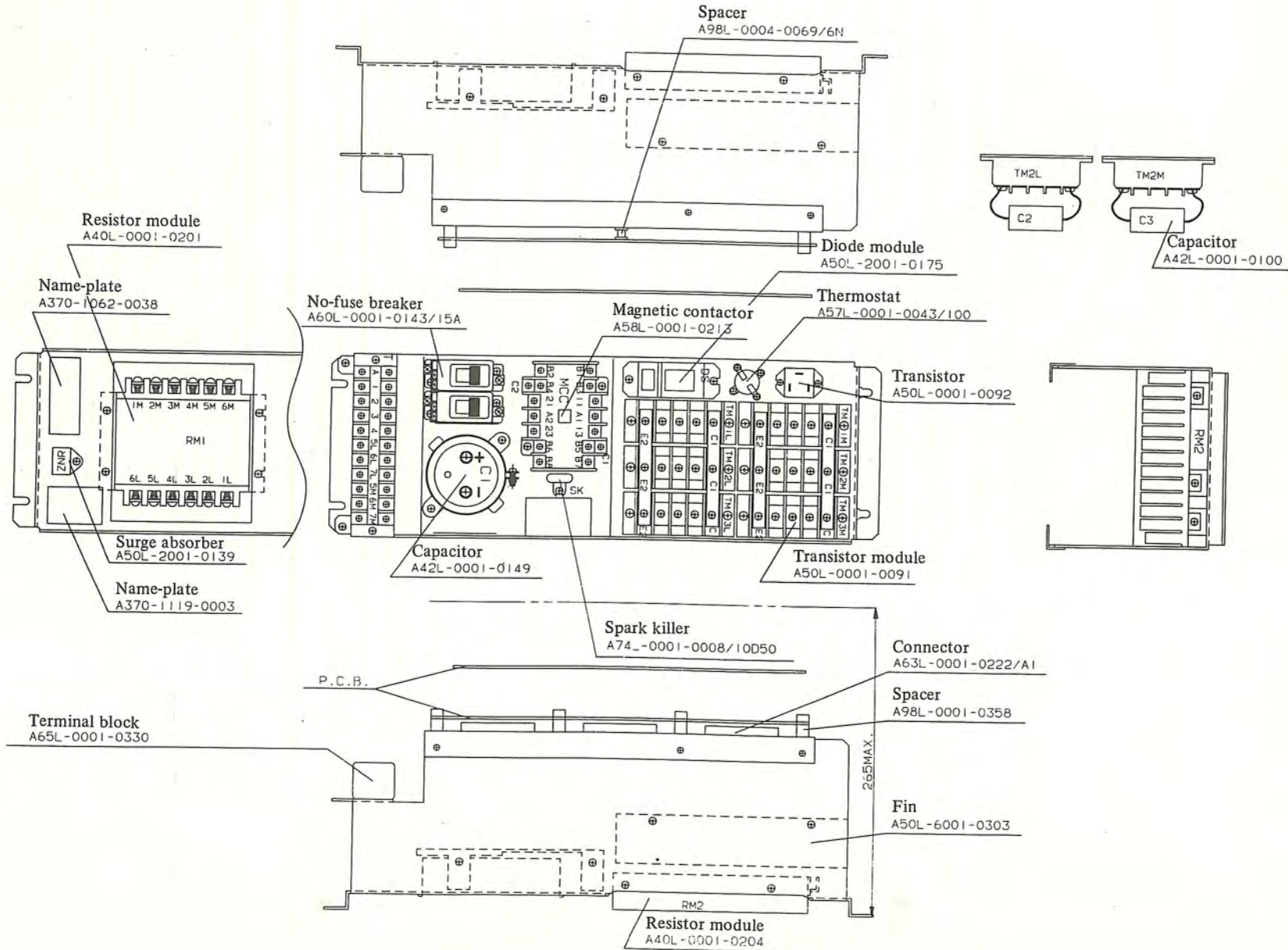

### III. AC SERVO UNIT FOR 3 AXES

This chapter describes the maintenance of AC servo unit for 3 axes which drives AC servo motor Model 0, 5, and 10.

Combination of three motors are described in Table 1.1.1. Refer to Table 1.1.1.

# 1. STRUCTURE

The AC servo unit for 3 axes consists of the velocity control unit, the power transformer and the discharge unit.

Four types of velocity control unit are available according to the combinations of AC servo motor models employed. One velocity control unit applies to three servo motors.

One power transformer is employed according to the combinations of motor model.

A regenerative discharge unit is a resistor unit which consumes the regenerated energy by the motor.

If the AC servo motor models employed are rather small type having a little regenerative energy, a regenerative discharge unit may be unnecessary. Fig. 1.1 shows a configuration example of an NC system with 3 controlled axes.

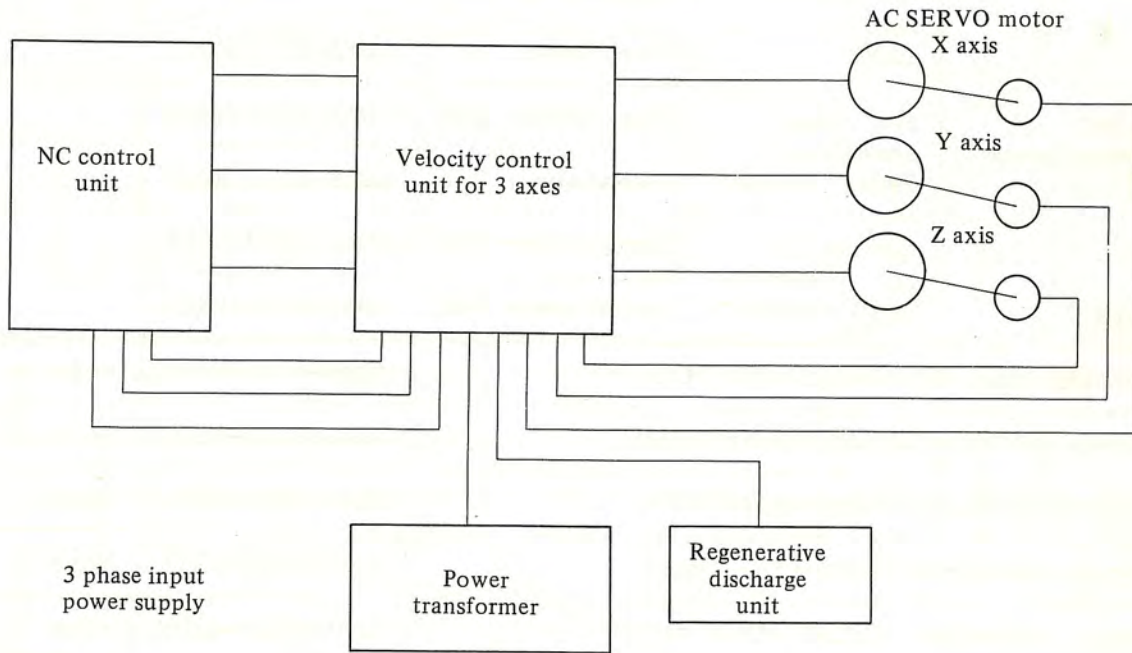

Fig. 1.1 A Typical Configuration Using an AC Servo Unit for 3 Axes

## 1.1 Types of Unit and Specification Number

Table 1.1 (a) Types of Units and Specification Number

Name	Applicable motor			Specification	Remarks
	L	M	N		
Velocity control unit	0/5	0/5	0/5	A06B-6050-H401	
	0/5	0/5	10	A06B-6050-H402	
	0/5	10	10	A06B-6050-H403	
	Note 1	10	10	A06B-6050-H404	
Power transformer	For Japan 200V 220V		Transformer MB	A06B-6047-H012	
			Transformer MC	A06B-6047-H013	
	For other countries 190V - 550V		Transformer MBE	A06B-6047-H022	
			Transformer MCE	A06B-6047-H023	
	Common to All countries 190V - 550V		Transformer ABE	A06B-6050-H022	
			Transformer ACE	A06B-6050-H023	
Note 2					
Regenerative discharge unit DCUA				A06B-6050-H050	Note 3
Regenerative discharge unit DCUB				A06B-6050-H052	Note 4
Regenerative discharge unit DCUC				A06B-6050-H051	Note 5
Input connector (Soldering type)				A06B-6050-K202	Note 6
Input connector (Crimp style type)				A06B-6050-K203	Note 7

Note 1. Specification number differs according to a motor combination.

Note 2. If the specifications of the velocity control unit are A06B-6050-H401 or -H402, one of transformers MB, MBE and ABE should be used.

If the specifications of velocity control units are A06B-6050-H403 or -H404, one of transformers MC, MCE and ACE should be used.

Note 3. To be used when the regenerative energy from the motors of three axes is rather large employing the velocity control unit A06B-6050-H401.

Note 4. To be used when the regenerative energy from the motors of three axes is rather large employing the velocity control unit A06B-6050-H402 or A06B-6050-H403.

Note 5. One set should be used for one velocity control unit A06B-6050-H404.

Note 6. Input connector includes connectors to be employed on the connecting cables to the velocity control unit. One set should be used for 3 axes.

Parts contained in the input connector (soldered type) are indicated in the Table 1.1(b).

Parts contained in the input connector (crimp style type) are indicated in the Table 1.1(c).

Table 1.1 (b) Parts Included in Input Connector (Soldering type)

Name	Q'ty	Use	Model	FANUC specifications
Connector + cover	3	CN1L,M,N	MR-20LFH *	A63L-0001-0134/02
Connector + cover	3	CN5L,M,N	MR-20LWMH *	A63L-0001-0134/15
Connector + cover	3	CN6L,M,N	MR-20LWFH *	A63L-0001-0134/05
Housing	1	CN2	SMS6PW-5 **	A63L-0001-0202/6W
Pin	5	CN2	RC16M-SCT3 **	A63L-0001-0226

Table 1.1 (c) Parts Included in Input Connector (Crimp style type)

Name	Q'ty	Use	Model	FANUC specifications
Connector + cover	3	CN1L,M,N	MR-20L, MRP-20F01 *	A63L-0001-0134/22
Connector + cover	3	CN5L,M,N	MR-20LW, MRP-20M01*	A63L-0001-0134/35
Connector + cover	3	CN6L,M,N	MR-20LW, MRP-20F01*	A63L-0001-0134/25
Contact	120	CN1,6	MRP-F112 *	A63L-0001-0134/F112
Contact	60	CN5	MRP-M112 *	A63L-0001-0134/M112
Housing	1	CN2	SMS6PW-5 **	A63L-0001-0202/6W
Pin	5	CN2	RC16M-S23A **	A63L-0001-0127/S23A

\* Manufacturer: HONDA Tsushin Co., Ltd.

\*\* Manufacturer: Burndy Japan Ltd.

## 2. CONNECTIONS

### 2.1 Connection Diagram

Fig. 2.1(a) shows standard connection diagram of A06B-6050-H401 - H403.

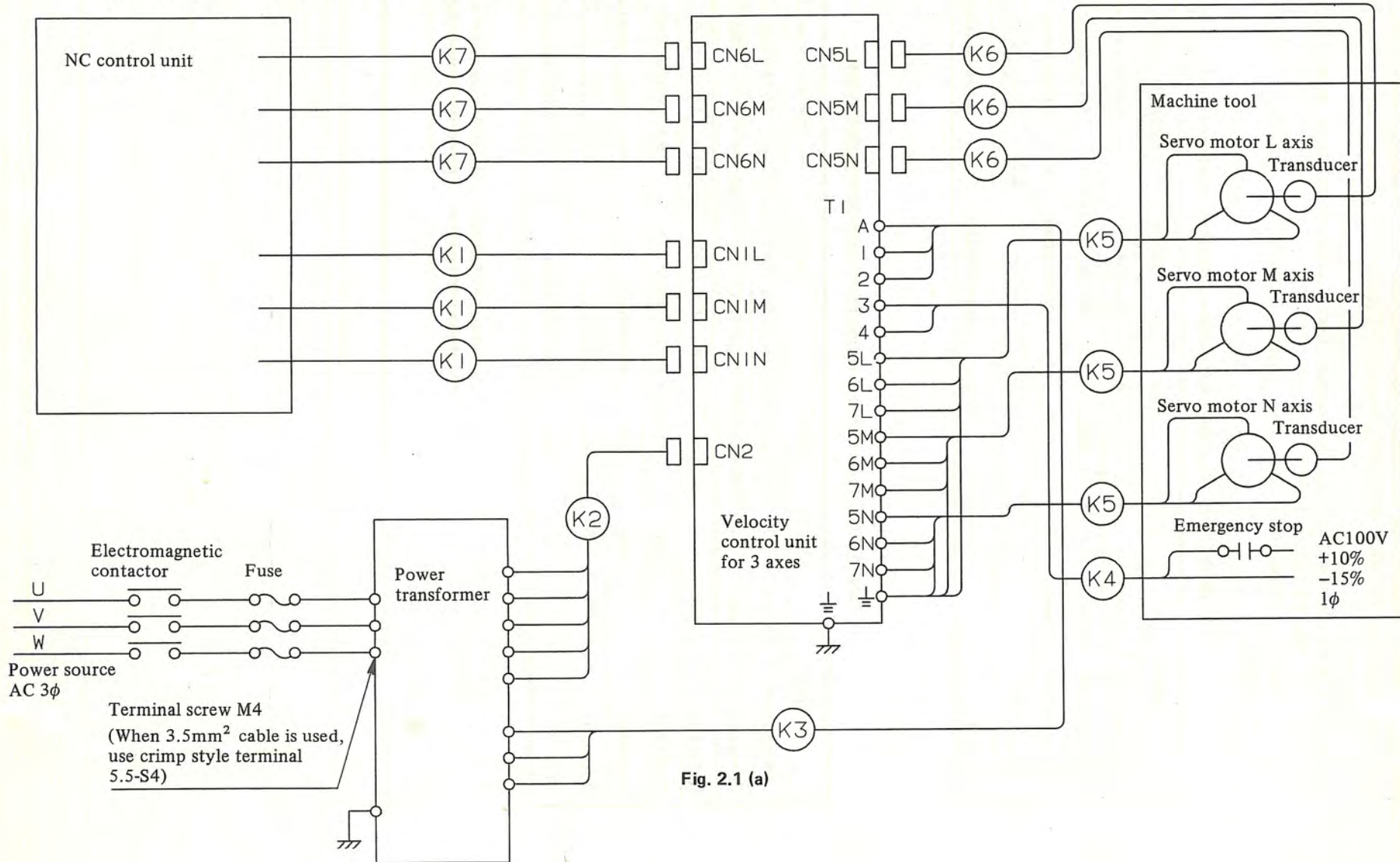

Fig. 2.1 (a)

Fig. 2.1(b) shows connection diagram of A06B-6050-H401 - H403 with regenerative discharge unit.

- 97 -

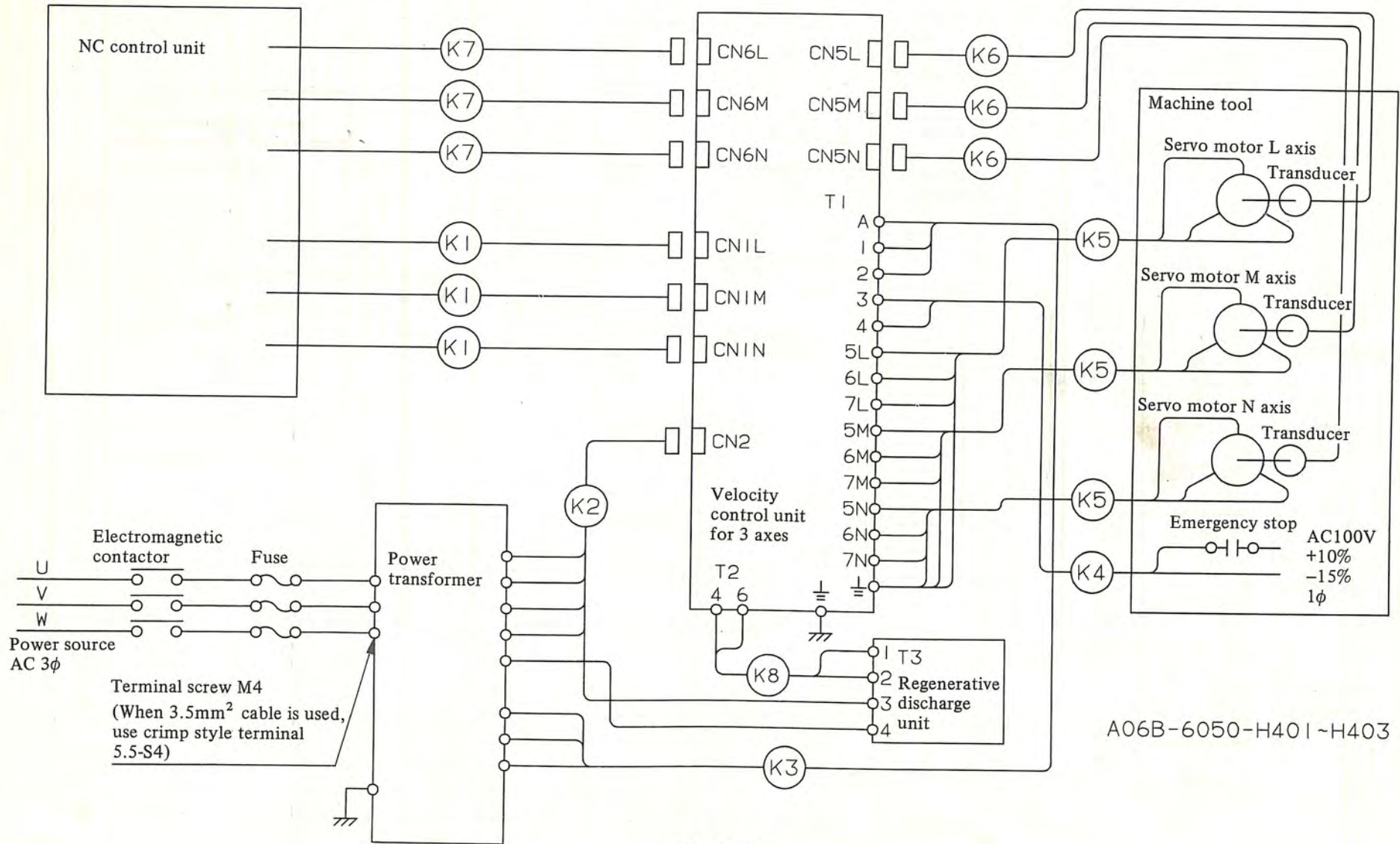

Fig. 2.1 (b)



Fig. 2.1(c) shows standard connection diagram of A06B-6050-H404.

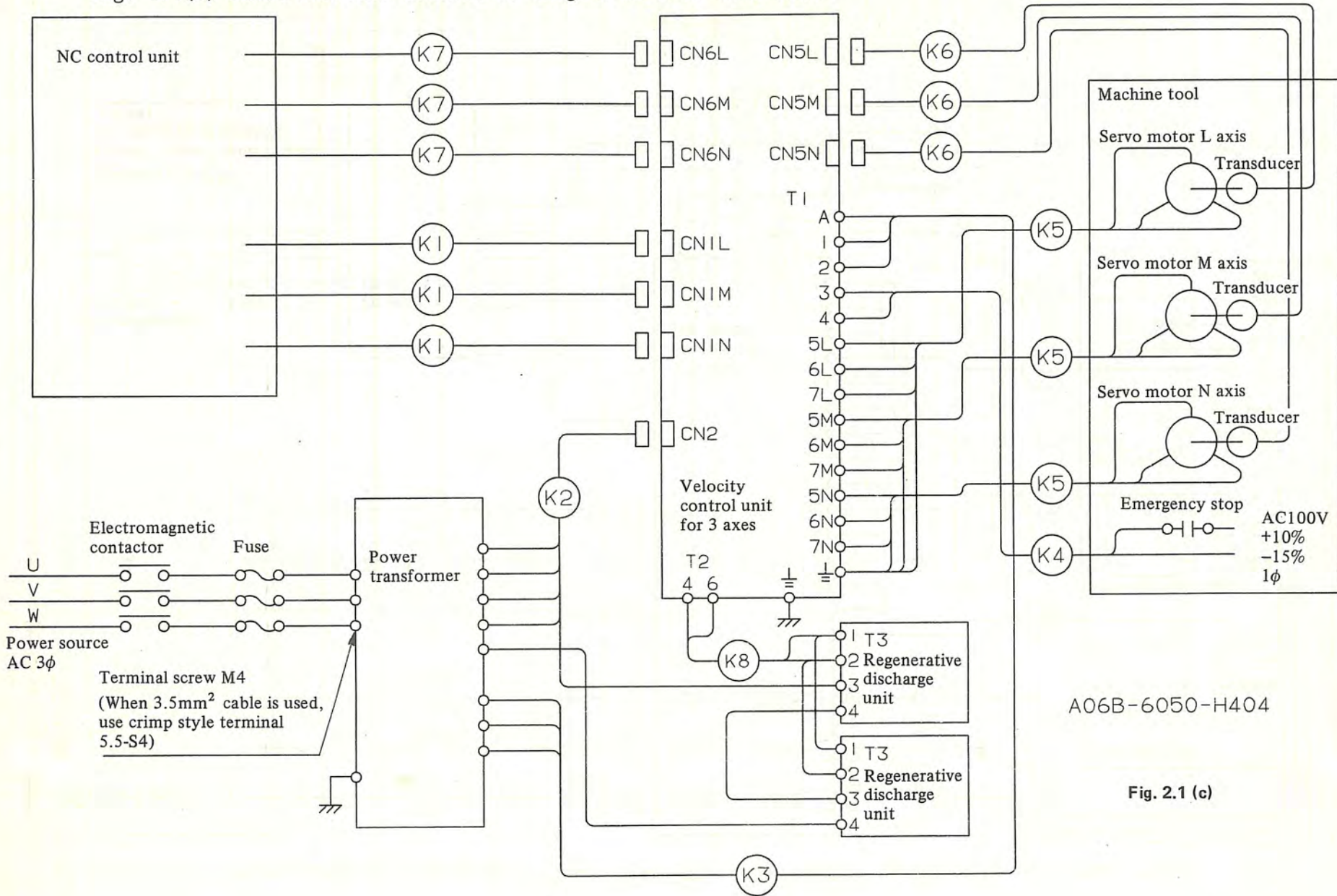

Fig. 2.1 (c)

## 2.2 Detailed Servo System Connection Diagram

### 2.2.1 Details of connections of cable K1

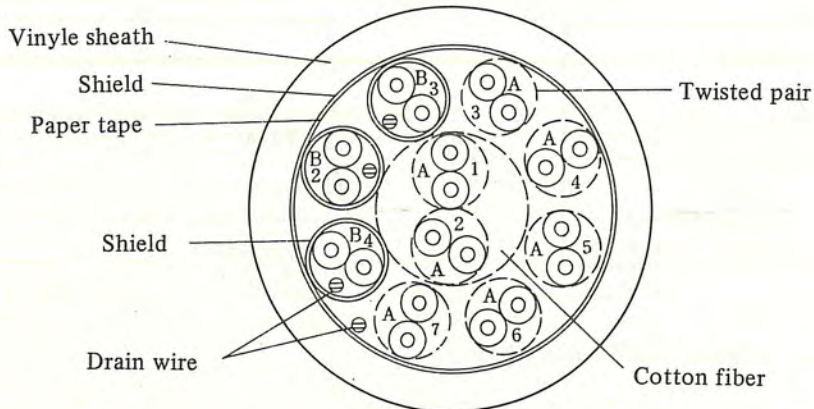
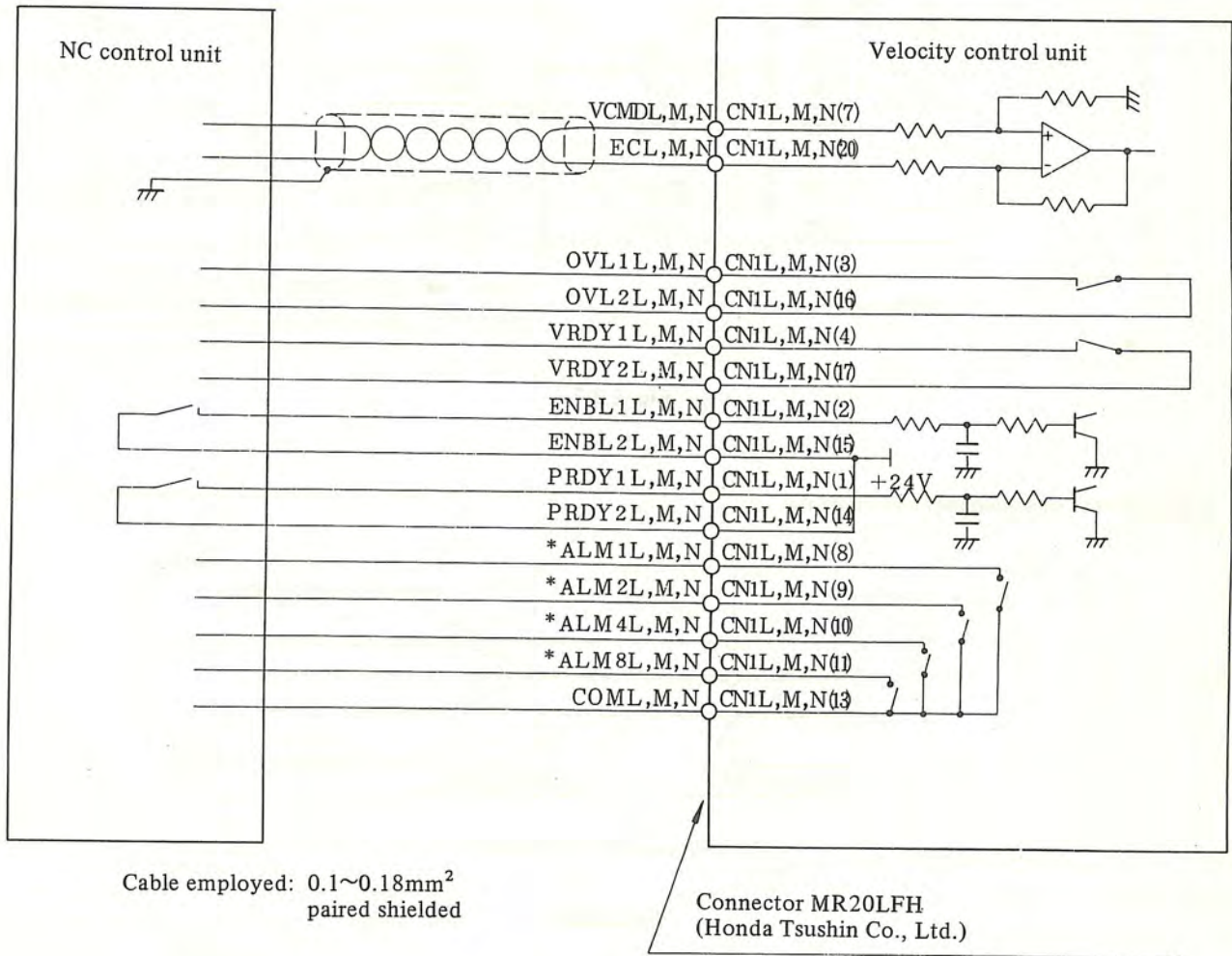

Fig. 2.2.1

### 2.2.2 Details of connections of cable K2

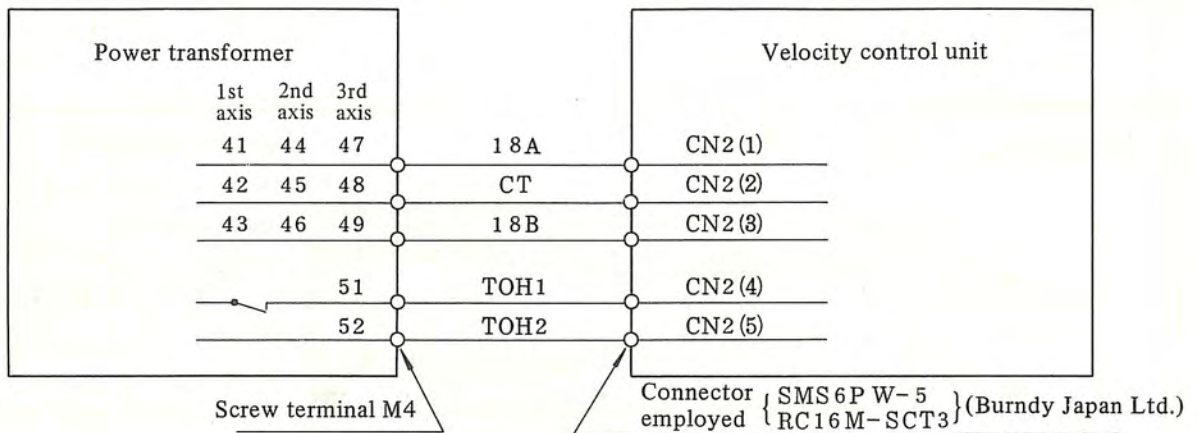
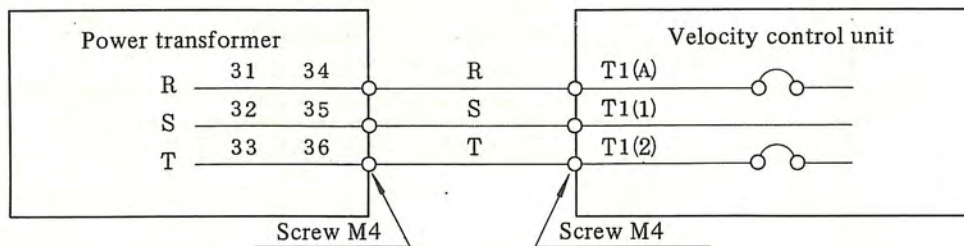

Fig. 2.2.2

### 2.2.3 Details of connections of cable K3



(Cable employed: 3.5mm<sup>2</sup>, 600V heat-resistive vinyl wire)

Fig. 2.2.3

### 2.2.4 Details of connections of cable K4

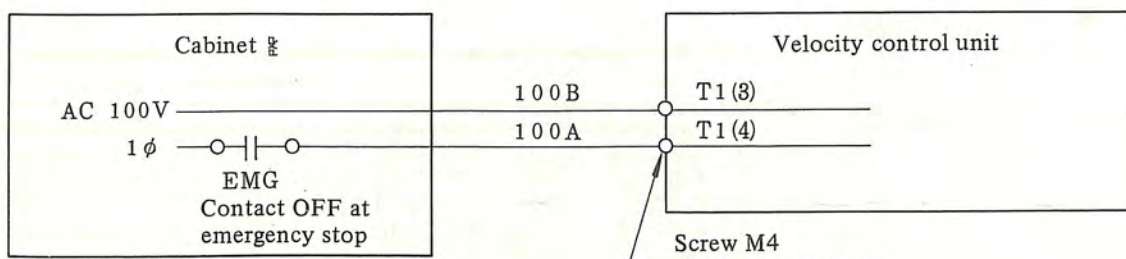

(Cable employed: 0.75mm<sup>2</sup>, 200V vinyl wire)

Fig. 2.2.4

2.2.5 Details of connections of cable K5

(1) Model 5, 0

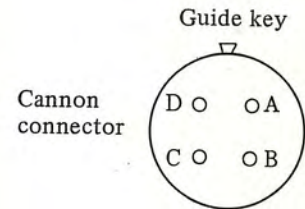
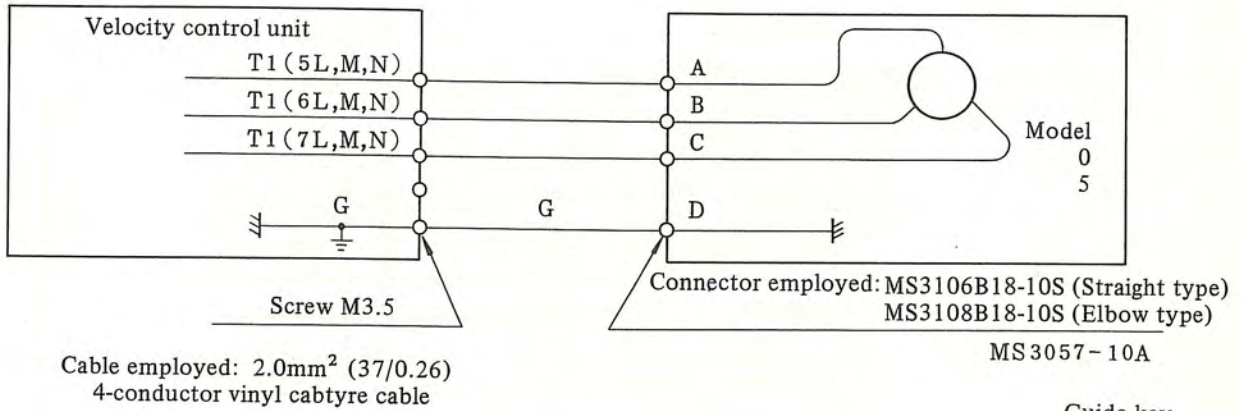

Fig. 2.2.5 (a)

(2) Model 10

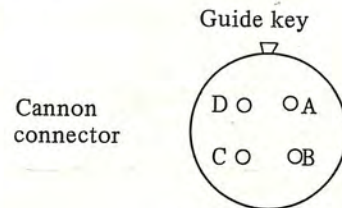
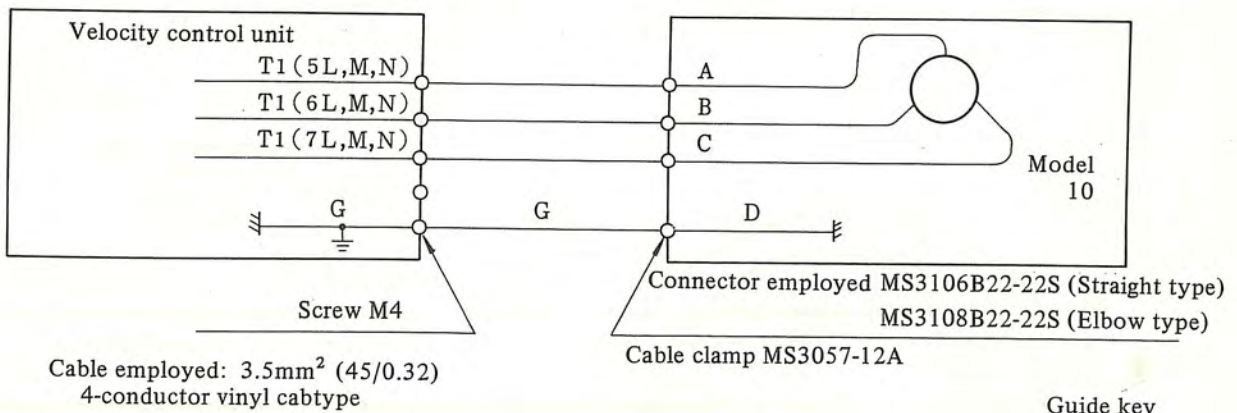

Fig. 2.2.5 (b)

2.2.6 Details of connections of cable K6

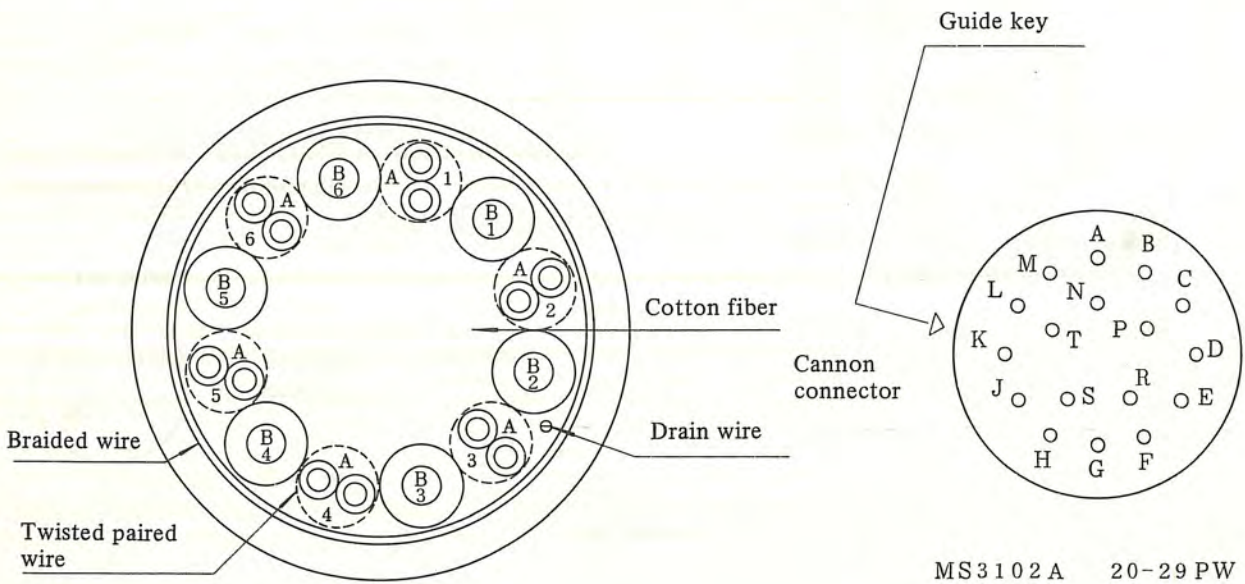
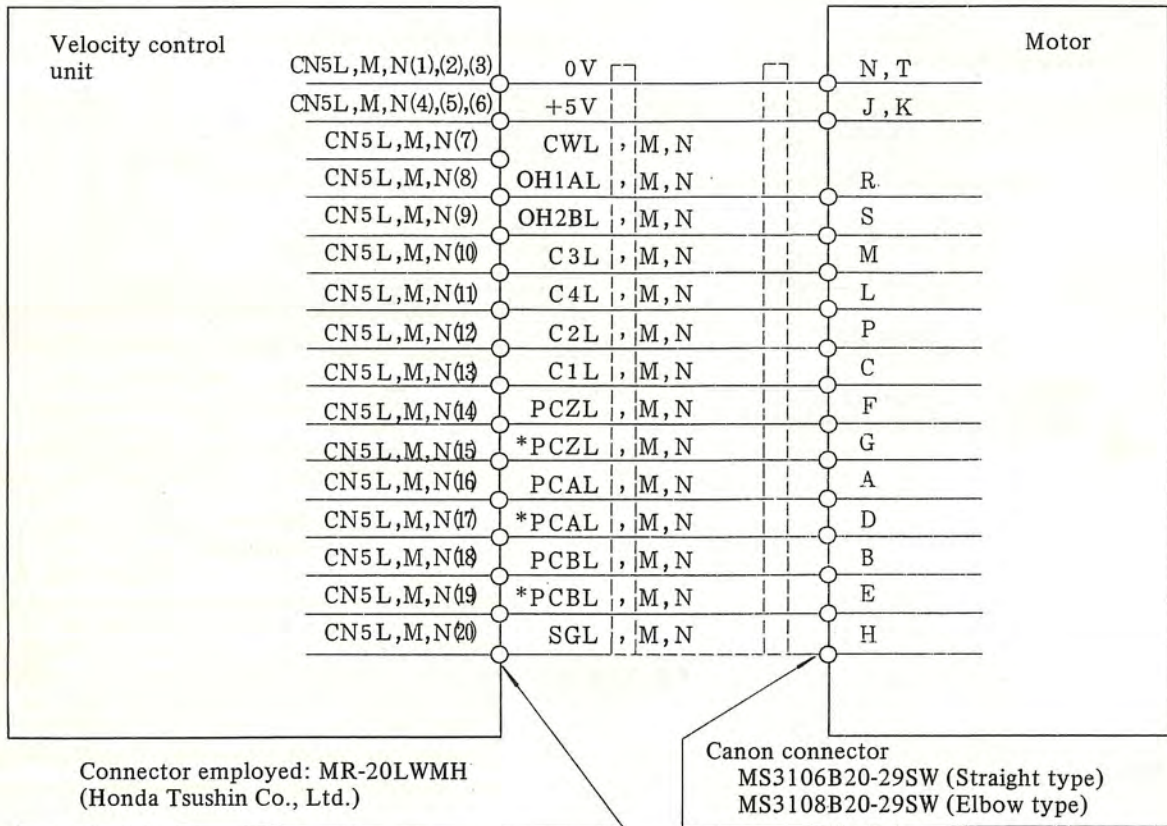

Fig. 2.2.6

2.2.7 Details of connections of cable K7

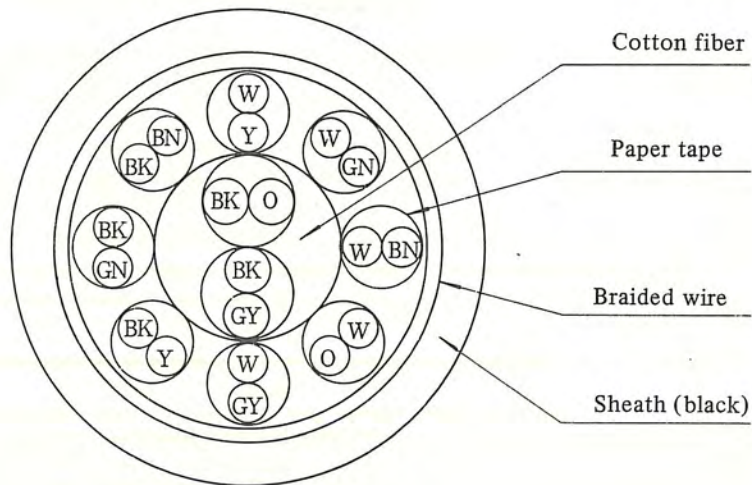
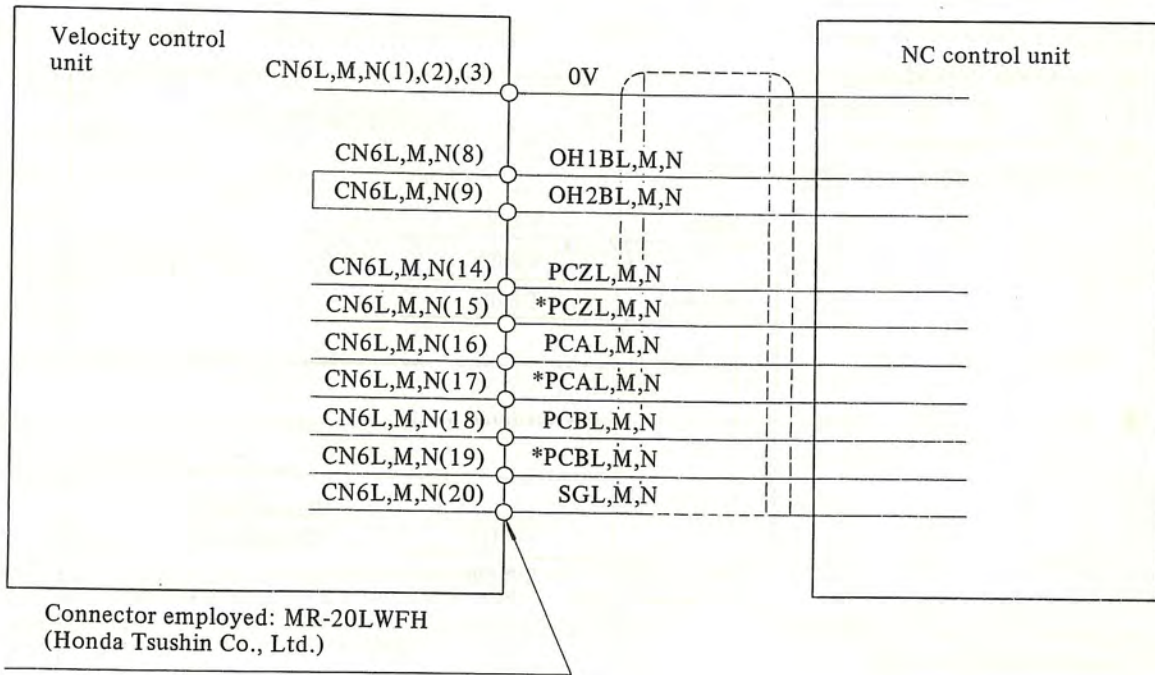

Fig. 2.2.7

## 2.2.8 Connections of separate discharge unit

- (1) In case of A06B-6050-H401 - H403 (option)  
(i) Details of connection of regenerative discharge unit

Disconnect the jumper wire from terminals T2 (4) - T2 (5) when the separate regenerative discharge unit is employed.

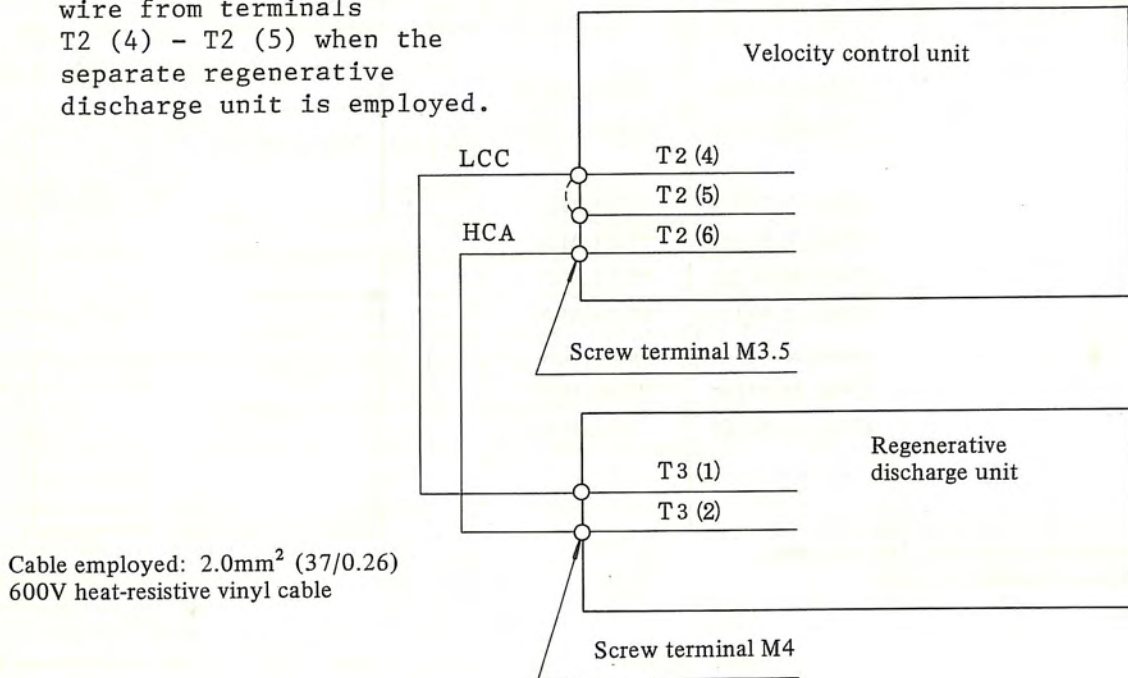

Fig. 2.2.8 (a)

(ii) Details of connection of cable K2

For connections of cable K2 in 9.1.2, change the connection of TOH1 and TOH2 as follows.

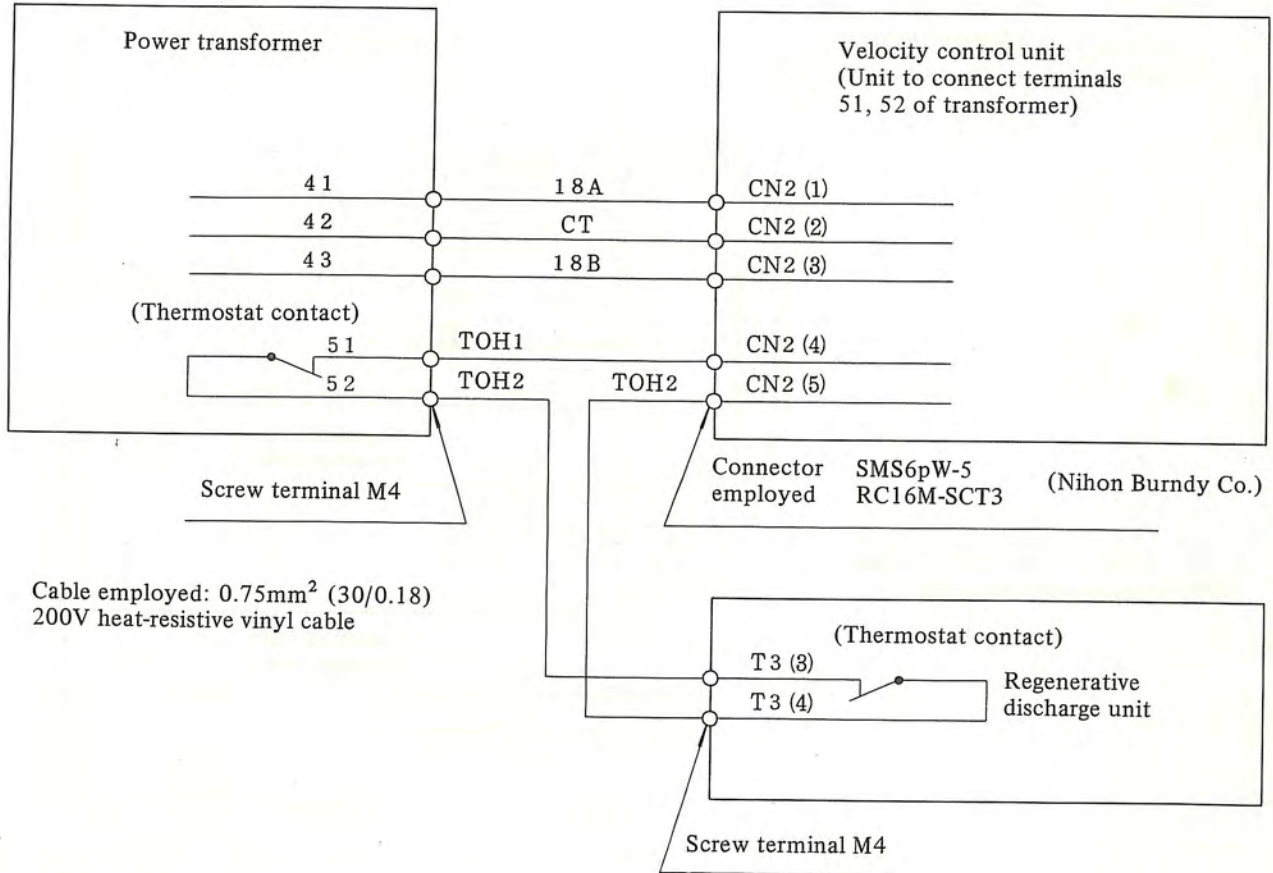

Fig. 2.2.8 (b)



- (2) In case of A06B-6050-H404 (standard)  
 (i) Details of connection of regenerative discharge unit

Disconnect the jumper wire from terminals T2 (4) - T2 (5) when the separate regenerative discharge unit is employed.

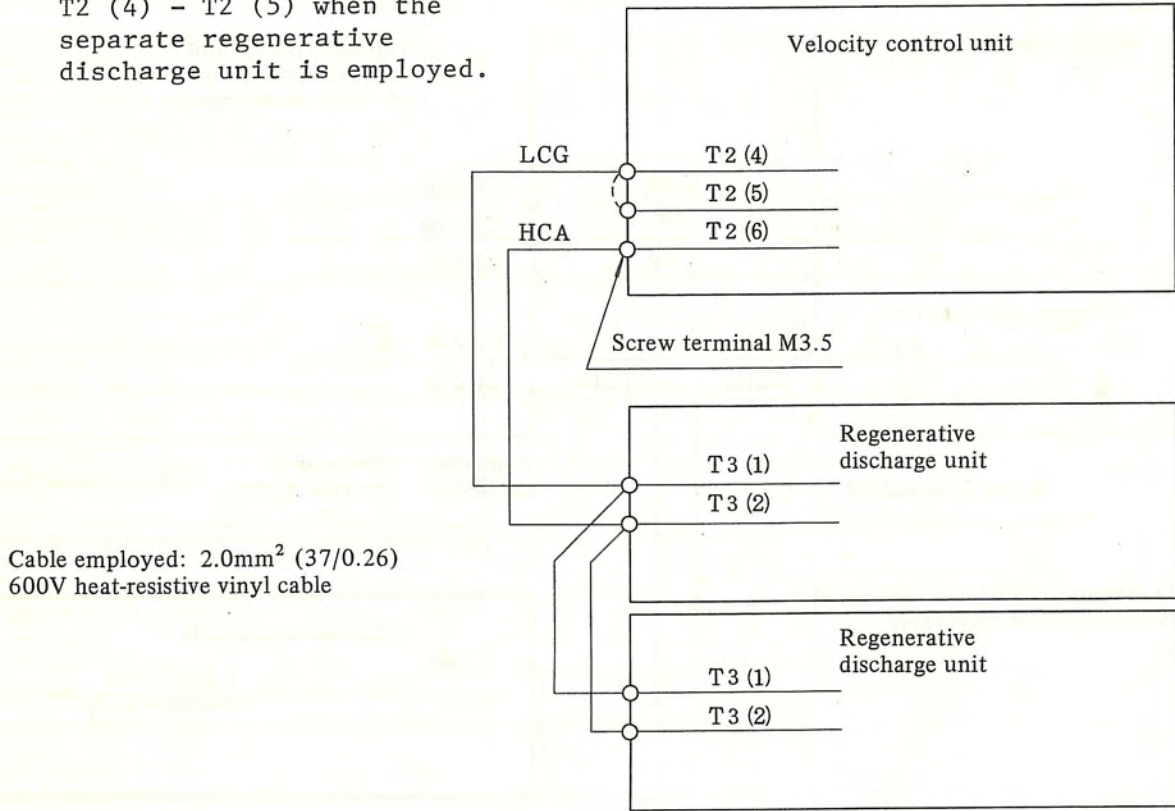

Fig. 2.2.8 (c)

- (ii) Details of connection of cable K2  
 For connections of cable K2 in 2.2.2, change the connection of TOH1 and TOH2 as follows.

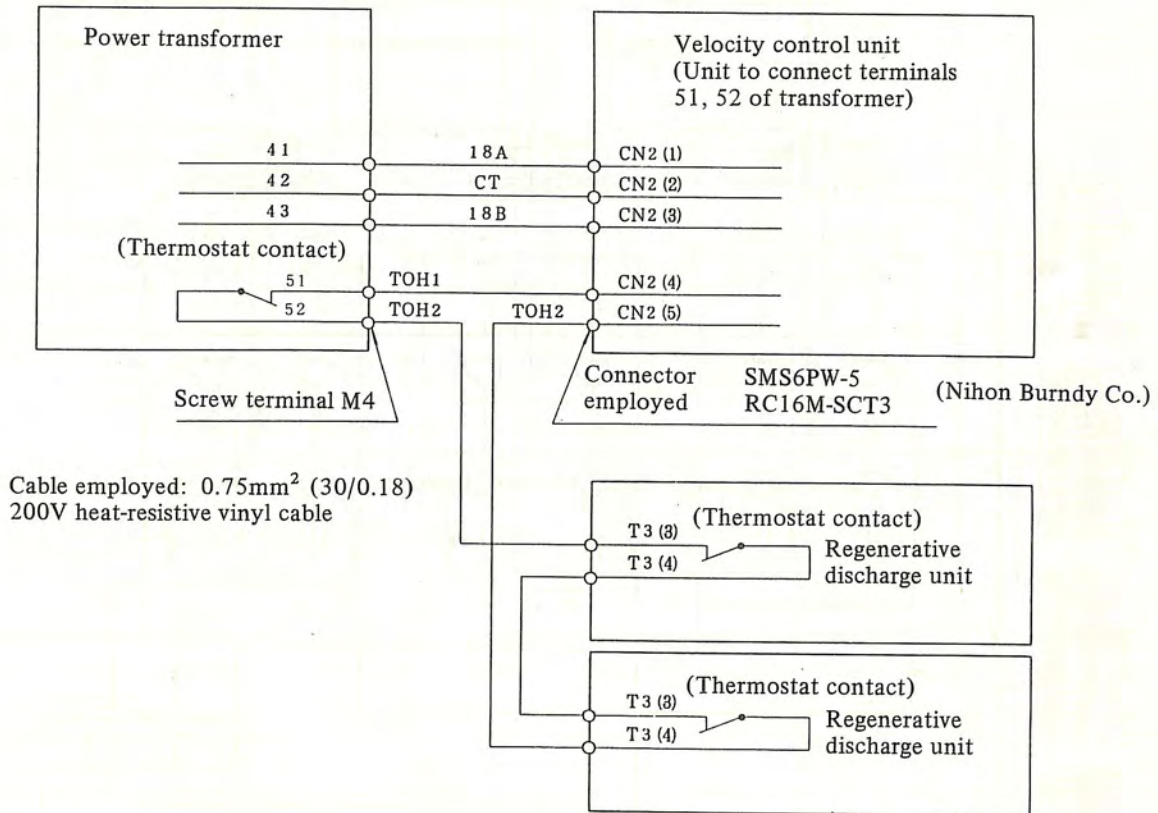

Fig. 2.2.8 (d)

### 2.3 Connection of Power Transformer

Refer to the same subsections in Chapter I in this manual.

## 2.4 Connection Diagram of Velocity Control Unit

### 2.4.1 Model 0/5, Model 0/5 and Model 0/5 (A06B-6050-H401)

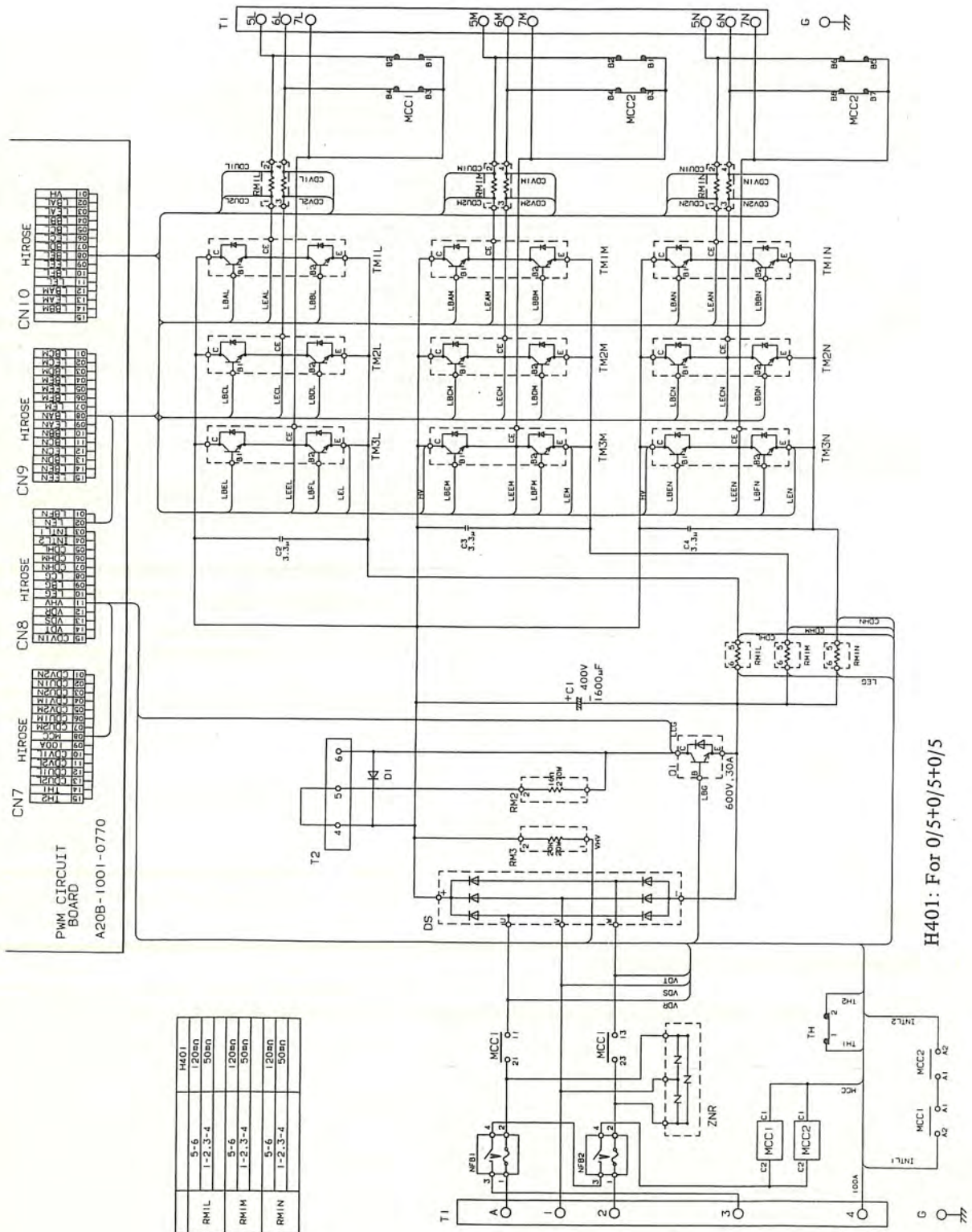
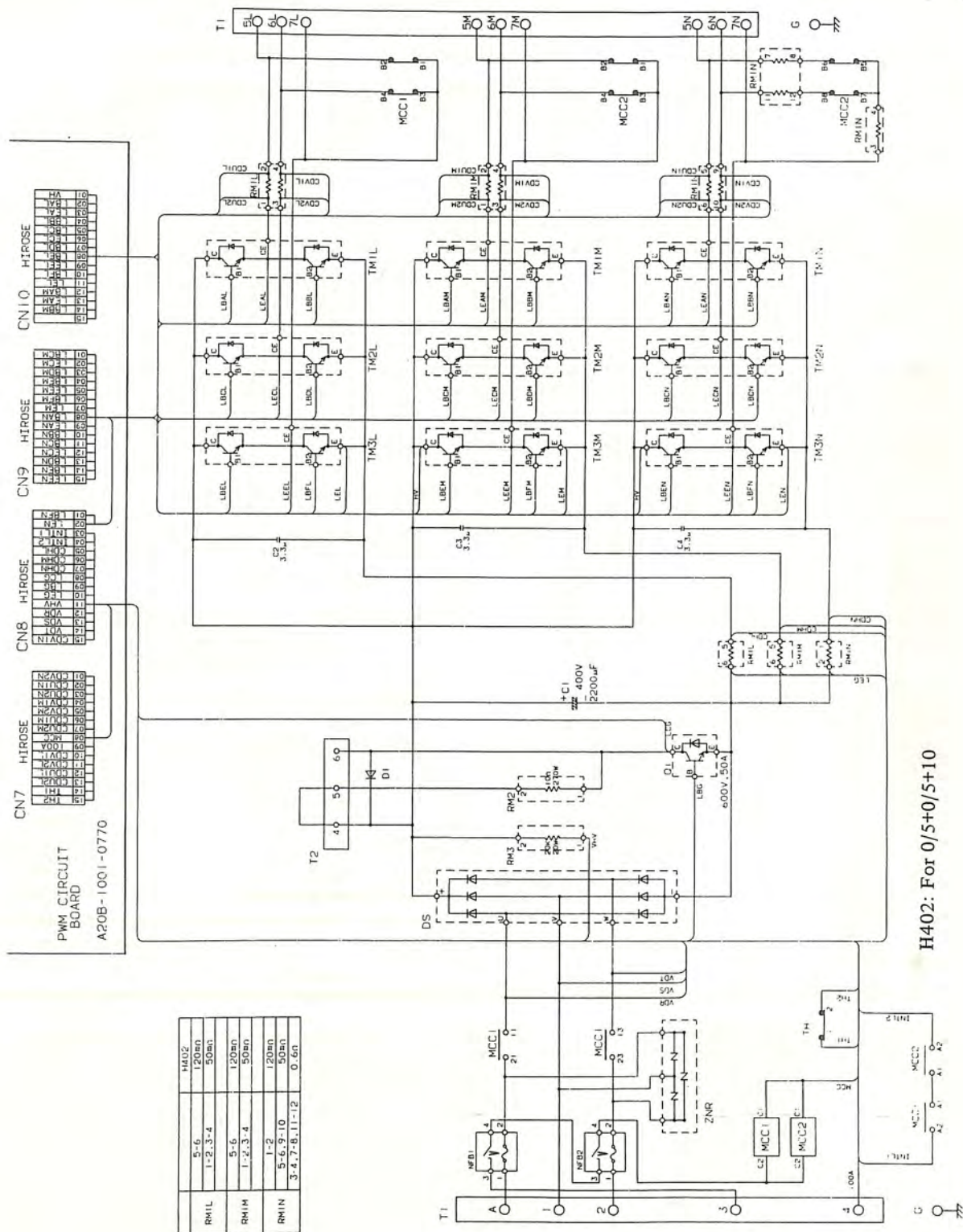

Fig. 2.4.1 Connection Diagram of Velocity Control Unit

2.4.2 Model 0/5, Model 0/5 and Model 10 (A06B-6050-H402)



H402: For 0/5+0/5+10

Fig. 2.4.2 Connection Diagram of Velocity Control Unit

2.4.3 Model 0/5, Model 10 and Model 10 (A06B-6050-H403)

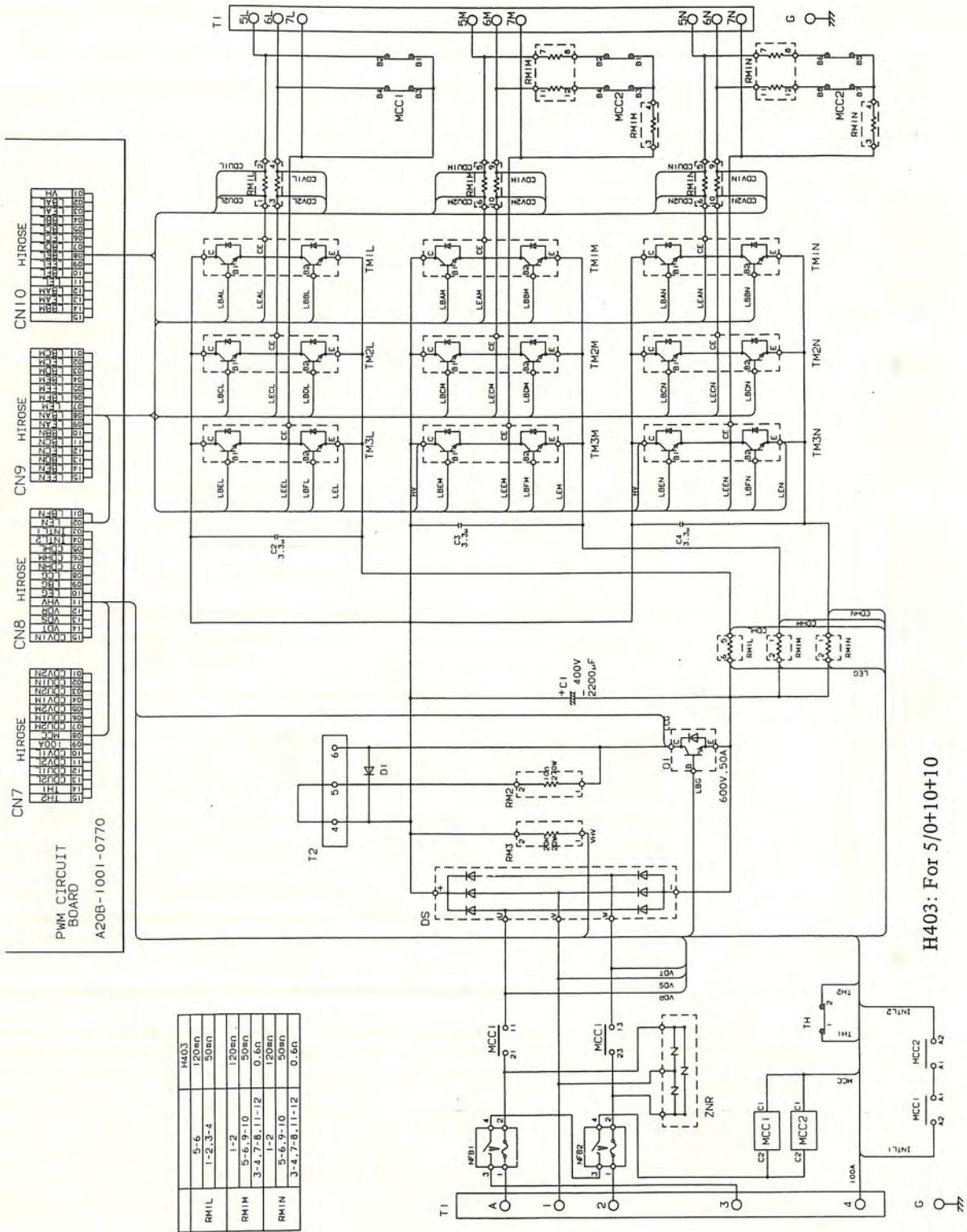

H403: For 5/0+10+10

Fig. 2.4.3 Connection Diagram of Velocity Control Unit

2.4.4 Model 10, Model 10 and Model 10 (A06B-6050-H404)

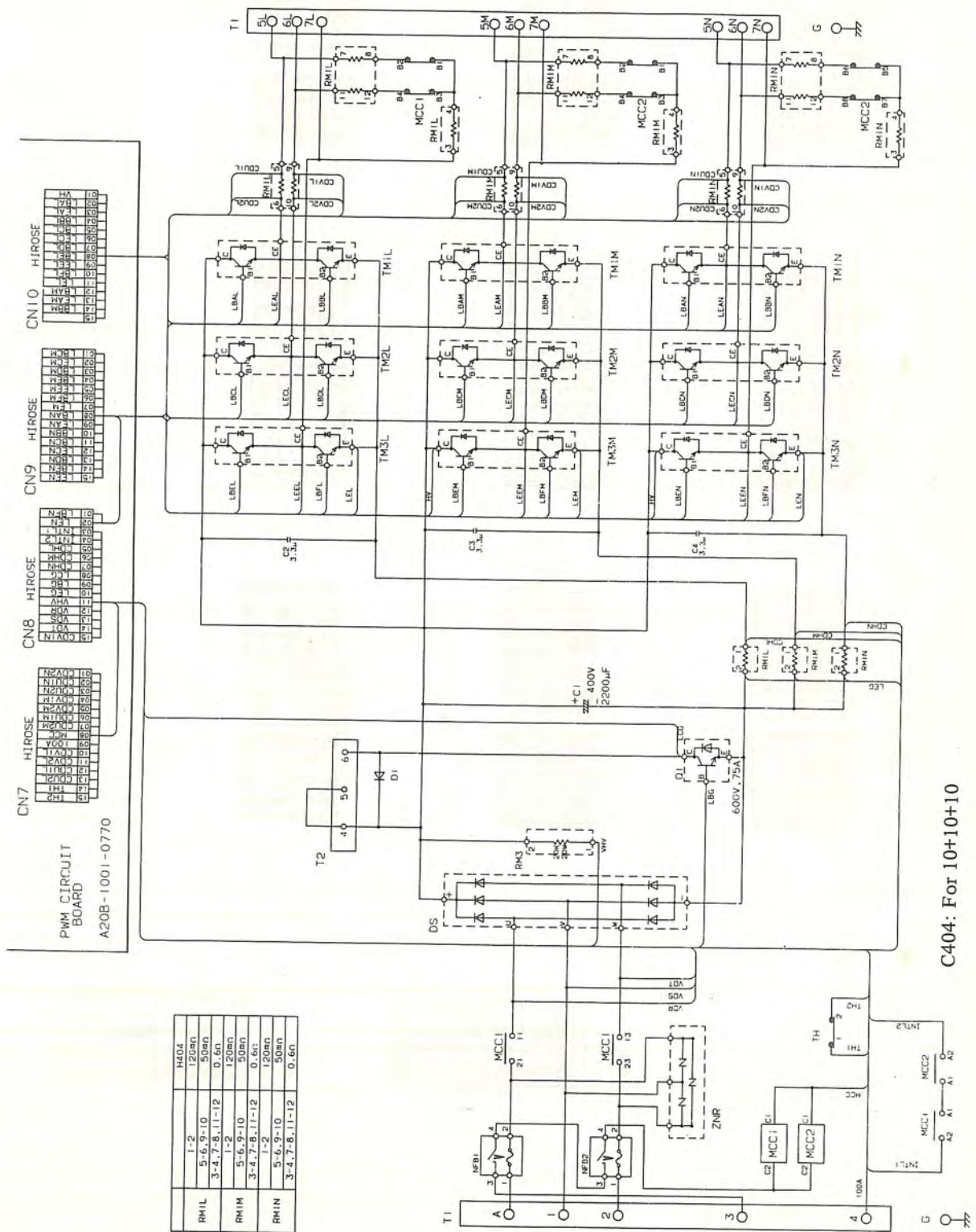

C404: For 10+10+10

Fig. 2.4.4 Connection Diagram of Velocity Control Unit

CN2  
BURNDY

1	18A
2	CT
3	18B
4	TOH1
5	TOH2
6	

CN11 (TO NC, VCMD)

14	PRDY2L	08	ALM1L	01	PRDY1L
15	ENBL2L	09	ALM2L	02	ENBL1L
16	OVL2L	10	ALM4L	03	OVL1L
17	VRDY2L	11	ALM8L	04	VRDY1L
18	CLMTL	12		05	CURRL
19		13	COML	06	
20	EL	MR-	20P07	VCMDL	

CN5L (TO PULCO)

01	0V	08	OH1AL	14	PCZL
02	0V	09	OH2AL	15	PCZL
03	0V	10	C8L	16	PCAL
04	+5V	11	C4L	17	PCAL
05	+5V	12	C2L	18	PCBL
06	+5V	13	C1L	19	PCBL
07	CWL	MR-	20S20	SGL	

CN6L (TO NC, PULCO FEEDBACK)

14	PCZL	08	OH1BL	01	0V
15	PCZL	09	OH2BL	02	0V
16	PCAL	10		03	0V
17	PCAL	11		04	
18	PCBL	12	CLMT1L	05	
19	PCBL	13	CLMT0L	06	
20	SGL	MR-	20P07	CLMT2L	

CN7

HIROSE

01	CDV2N
02	CDU1N
03	CDU2N
04	CDV1M
05	CDV2M
06	CDU1M
07	CDU2M
08	MCC
09	100A
10	CDV1L
11	CDV2L
12	CDU1L
13	CDU2L
14	TH1
15	TH2

CN9

HIROSE

01	LBCM
02	LECM
03	LBDM
04	LBFM
05	LEEM
06	LBFM
07	LEM
08	LBAN
09	LEAN
10	LBBN
11	LBCN
12	LECN
13	LBDN
14	LBFN
15	LEEN

CN1M (TO NC, VCMD)

14	PRDY2M	08	ALM1M	01	PRDY1M
15	ENBL2M	09	ALM2M	02	ENBL1M
16	OVL2M	10	ALM4M	03	OVL1M
17	VRDY2M	11	ALM8M	04	VRDY1M
18	CLMTM	12		05	CURRM
19		13	COMM	06	
20	EM	MR-	20P07	VCMDM	

CN5M (TO PULCO)

01	0V	08	OH1AM	14	PCZM
02	0V	09	OH2AM	15	PCZM
03	0V	10	C8M	16	PCAM
04	+5V	11	C4M	17	PCAM
05	+5V	12	C2M	18	PCBM
06	+5V	13	C1M	19	PCBM
07	CWM	MR-	20S20	SGM	

CN6M (TO NC, PULCO FEEDBACK)

14	PCZM	08	OH1BM	01	0V
15	PCZM	09	OH2BM	02	0V
16	PCAM	10		03	0V
17	PCAM	11		04	
18	PCBM	12	CLMT1M	05	
19	PCBM	13	CLMT0M	06	
20	SGM	MR-	20P07	CLMT2M	

CN1N (TO NC, VCMD)

14	PRDY2N	08	ALM1N	01	PRDY1N
15	ENBL2N	09	ALM2N	02	ENBL1N
16	OVL2N	10	ALM4N	03	OVL1N
17	VRDY2N	11	ALM8N	04	VRDY1N
18	CLMTN	12		05	CURRN
19		13	COMM	06	
20	EN	MR-	20P07	VCMDN	

CN5N (TO PULCO)

01	0V	08	OH1AN	14	PCZN
02	0V	09	OH2AN	15	PCZN
03	0V	10	C8N	16	PCAN
04	+5V	11	C4N	17	PCAN
05	+5V	12	C2N	18	PCBN
06	+5V	13	C1N	19	PCBN
07	CWN	MR-	20S20	SGN	

CN6N (TO NC, PULCO FEEDBACK)

14	PCZN	08	OH1BN	01	0V
15	PCZN	09	OH2BN	02	0V
16	PCAN	10		03	0V
17	PCAN	11		04	
18	PCBN	12	CLMT1N	05	
19	PCBN	13	CLMT0N	06	
20	SGN	MR-	20P07	CLMT2N	

CN8

HIROSE

01	LBFN
02	LEN
03	INTL1
04	INTL2
05	CDHL
06	CDHM
07	CDHN
08	LCG
09	LBG
10	LEG
11	VHV
12	VDR
13	VDS
14	VDT
15	CDVIN

CN10

HIROSE

01	VH
02	LBAL
03	LEAL
04	L5BL
05	L6CL
06	LECL
07	LBDL
08	LBFL
09	LEFL
10	LBFL
11	LEL
12	LBAM
13	LEAM
14	L5BL
15	

### 3. SETTING AND ADJUSTMENT OF VELOCITY CONTROL UNIT

#### 3.1 Setting and Adjustment of Velocity Control Unit PCB

##### 3.1.1 Parts location

PCB A20B-1001-0770

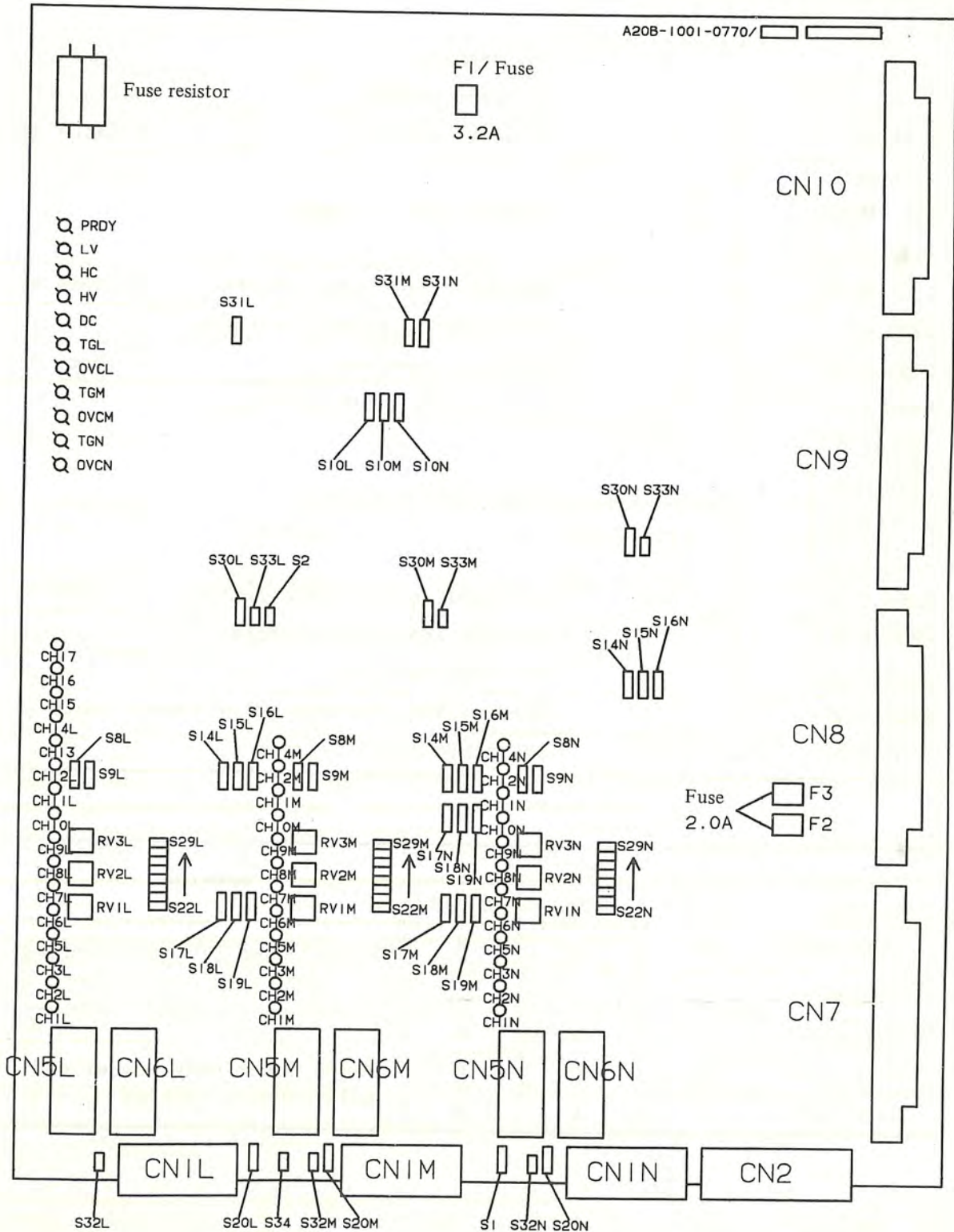

Fig. 3.1.1



### 3.1.2 Setting terminal

PCB A20B-1001-0770

Table 3.1.2

Terminal setting	Standard setting		Remarks
	0/5	10	
S1	L	L	TOH setting (Note 1)
S2	x	x	DC alarm setting (Note 2)
S10L,M,N	H	H	TG alarm enable (Note 3)
S17L,M,N	H	H	Current limit setting
S18L,M,N	L	L	
S19L,M,N	H	H	
S20L,M,N	H	H	Absolute code output enable (Note 4)
S22L,M,N	o	x	Compensation circuit setting
S23L,M,N	o	x	VCMD gain setting (Note 5)
S24L,M,N	o	o	F/V circuit filter setting
S25L,M,N	x	x	Compensation circuit
S26L,M,N	x	x	
S27L,M,N	x	x	
S28L,M,N	x	x	
S29L,M,N	x	x	F/V input pulse width setting (Note 6)
S30L,M,N	L	L	Current loop gain setting
S31L,M,N	H	H	TG alarm enable
S32L,M,N	o	o	Setting for absolute pulse coder (Note 7)
S33L,M,N	x	x	OVC alarm level setting

Terminal setting	Pulse coder			Remarks
	2000P	2500P	3000P	
S8L,M,N	L	L	H	Pulse coder F/V gain setting
S9L,M,N	H	L	L	
S14L,M,N	L	H	H	Pulse coder pole number and pulse number setting
S15L,M,N	H	L	L	
S16L,M,N	H	L	H	

Terminal setting	NC system		Remarks
	FS0,FS1,FS2,FS3,FS6,FS9	FS10,FS11,FS12	
S34	x	o	VRDY signal setting

- Note 1. If the power transformer is connected to terminals CN2(4) and (5), set S1 at L side.
- Note 2. If the regenerative discharge unit is mounted, set S2 in the short-circuit state. If it is not mounted, set S2 in the open state.
- Note 3. If check is required without connection of the motor power cable, set S10 at L side.
- Note 4. If S20 is set at L side, absolute codes from the pulse coder is output to NC while VRDY is on. If VRDY is turned OFF, the alarm code is output. If S20 is set at H, the alarm code is always output.
- Note 5. If S23 is short-circuited, 7V/2000 rpm is set, and if it is open, 7V/1000 rpm is set.
- Note 6. If S29 is short-circuited, the velocity feedback voltage is changed from 3V/1000 rpm to 1.5V/1000 rpm. Normally, set it in the open state.
- Note 7. If ABS pulse coder is used, set S32 in the open state.
- Note 8. Setting operations are shown in the Fig. below.

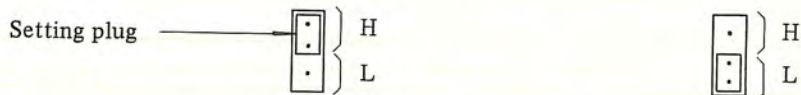

(a) Set at H side

(b) Set at L side

### 3.1.3 Variable resistor

Table 3.1.3

Volume	Standard setting	Remarks
RV1L,RV1M,RV1N	50%	Gain setting
RV2L,RV2M,RV2N	-	Adjustment of offset voltage
RV3L,RV3M,RV3N	-	Adjustment of velocity feedback voltage

- Note 1. RV2L,M,N and RV3L,M,N are adjusted before shipping from the factory.

### 3.1.4 Check terminals

Table 3.1.4

Check terminal	Symbol	Contents	
CH1L,M,N	VCMD	a x velocity command voltage	(Note 1)
CH2L,M,N	TSA	0.8 x velocity feedback voltage	
CH3L,M,N	0V	0V	
CH5L,M,N		Compensation circuit	
CH6L,M,N			
CH7L,M,N	R	R-phase current command	
CH8L,M,N	S	S-phase current command	
CH9L,M,N	T	T-phase current command	
CH10L,M,N	IR	R-phase current feedback	5.45A/V (Motor 0,5,10)
CH11L,M,N	IS	S-phase current feedback	
CH12L,M,N	IT	T-phase current feedback	
CH13	TRW	Triangle wave	(Note 2)
CH14L,M,N	ER	Error voltage (Torquecommand)	
CH15	+5V	+5V	
CH16	+15V	+15V	
CH17	-15V	-15V	

Note 1. a = 0.344 when VCMD is 7V/1000 rpm

a = 0.687 when VCMD is 7V/2000 rpm

Note 2. Wave form of triangle wave is as follows.

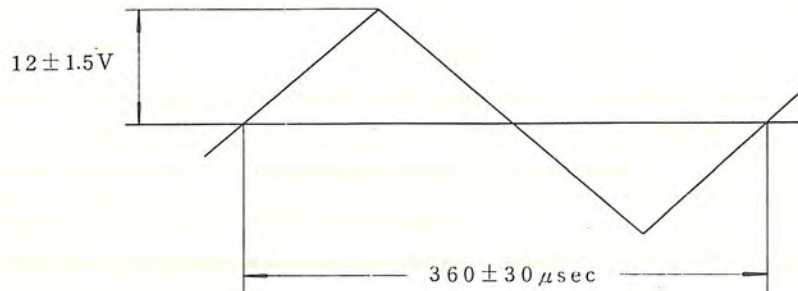

Note 3. Motor load currents (peak values) can be monitored using the same conversion as CH10-12. The effective values can be obtained by multiplying  $1/\sqrt{2}$ .

3.2 Block Diagram of Velocity Control Unit

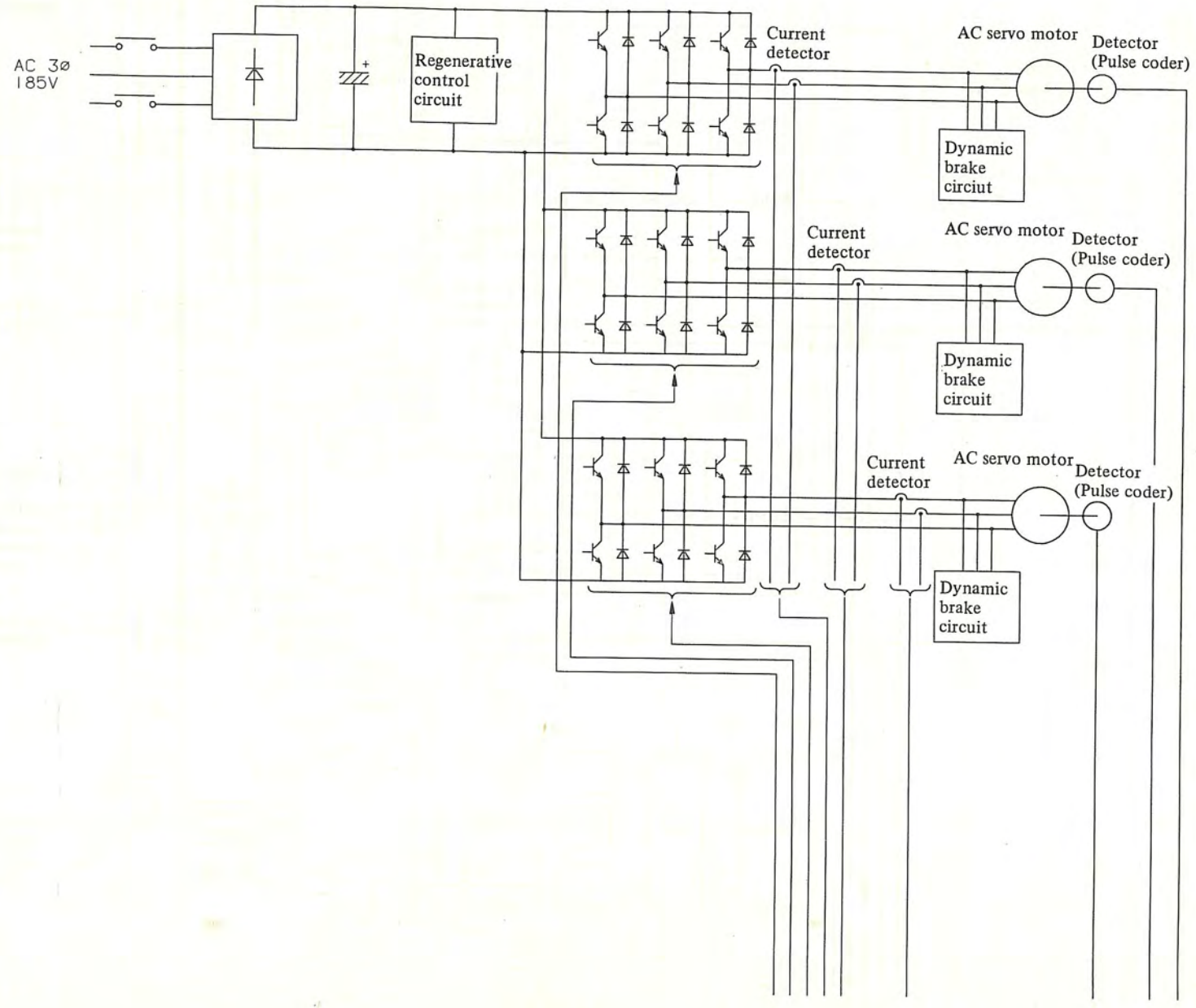
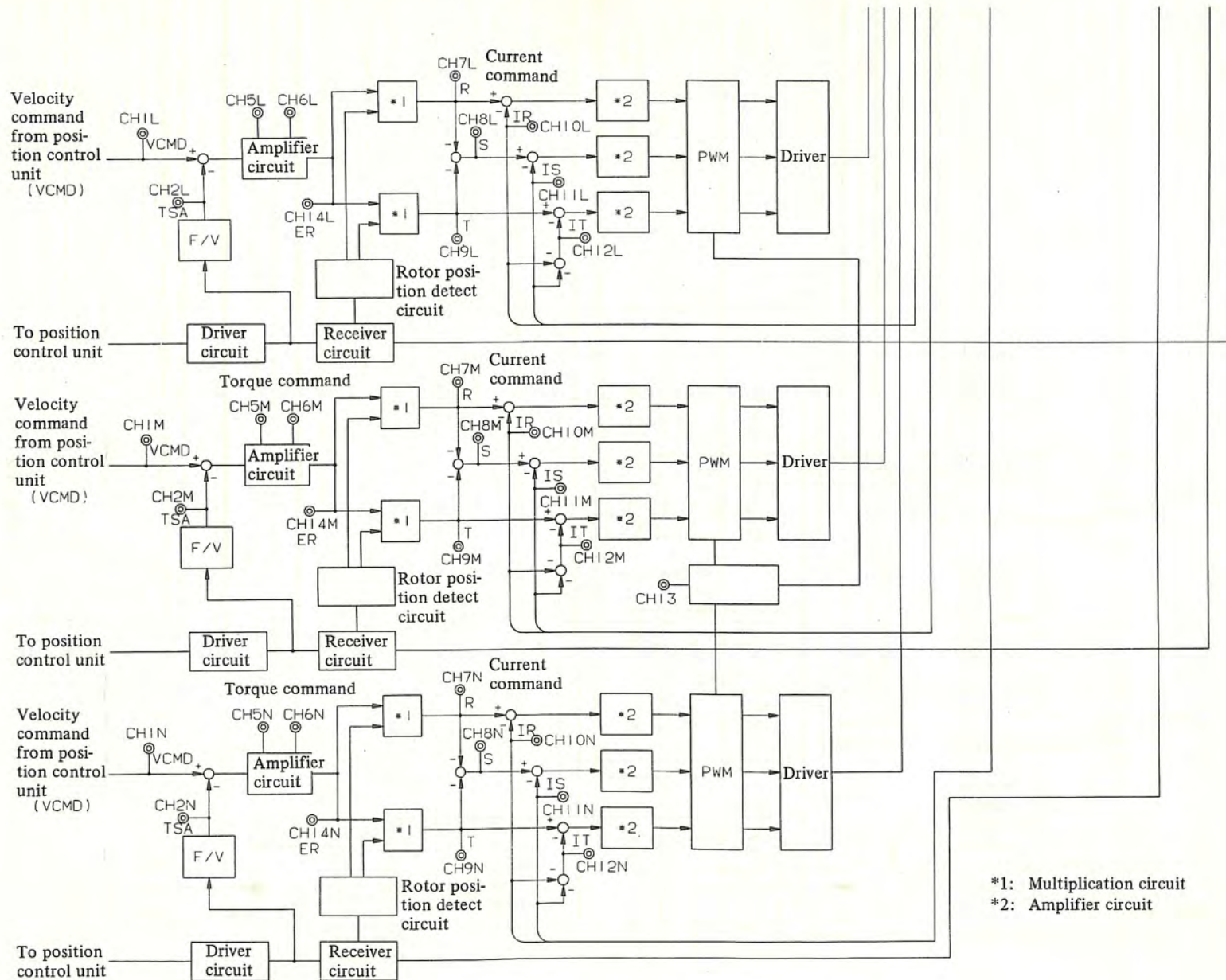

Fig. 3.2



## 4. TROUBLESHOOTING

### 4.1 Protection and Fault Detecting Function

### 4.2 Troubleshooting

For subsection 4 - 4.2 refer to the same subsection in Chapter I in this manual.

## 5. PARTS SPECIFICATION AND LOCATIONS ON VELOCITY UNIT

### 5.1 Model 0/5, Model 0/5 and Model 0/5 (A06B-6050-H401)

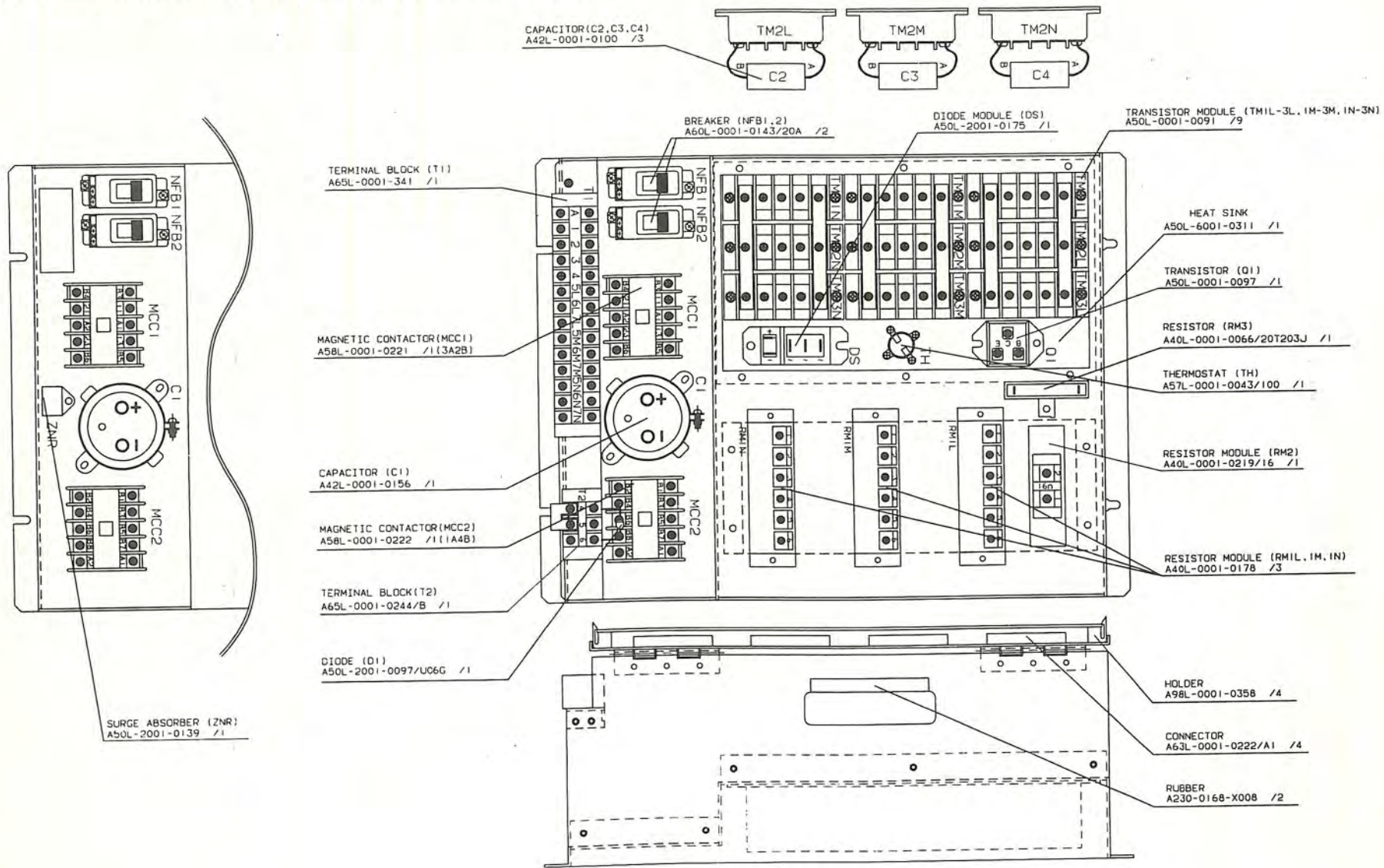

## 5.2 Model 0/5, Model 0/5 and Model 10 (A06B-6050-H402)

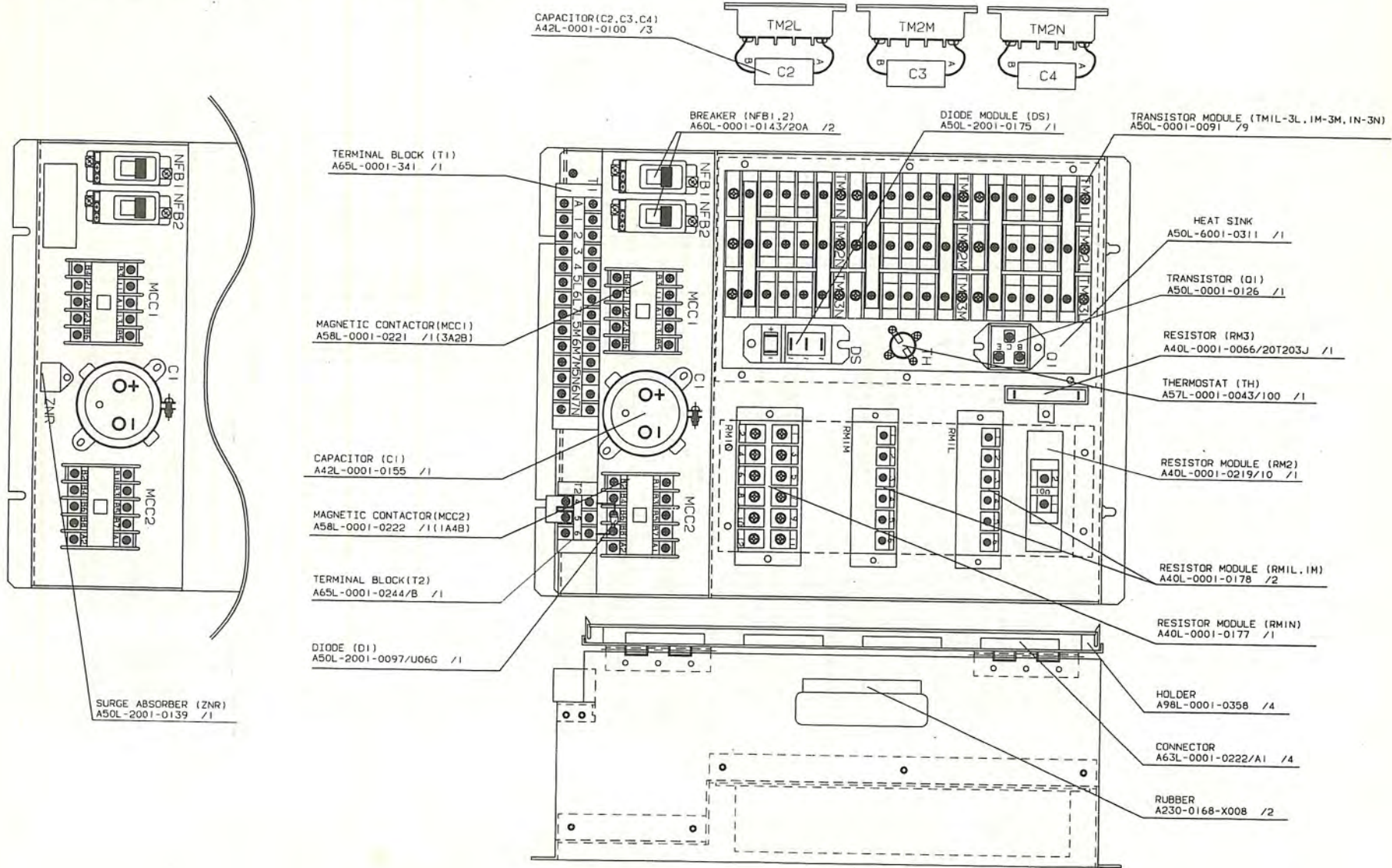



### 5.3 Model 0/5, Model 10 and Model 10 (A06B-6050-H403)

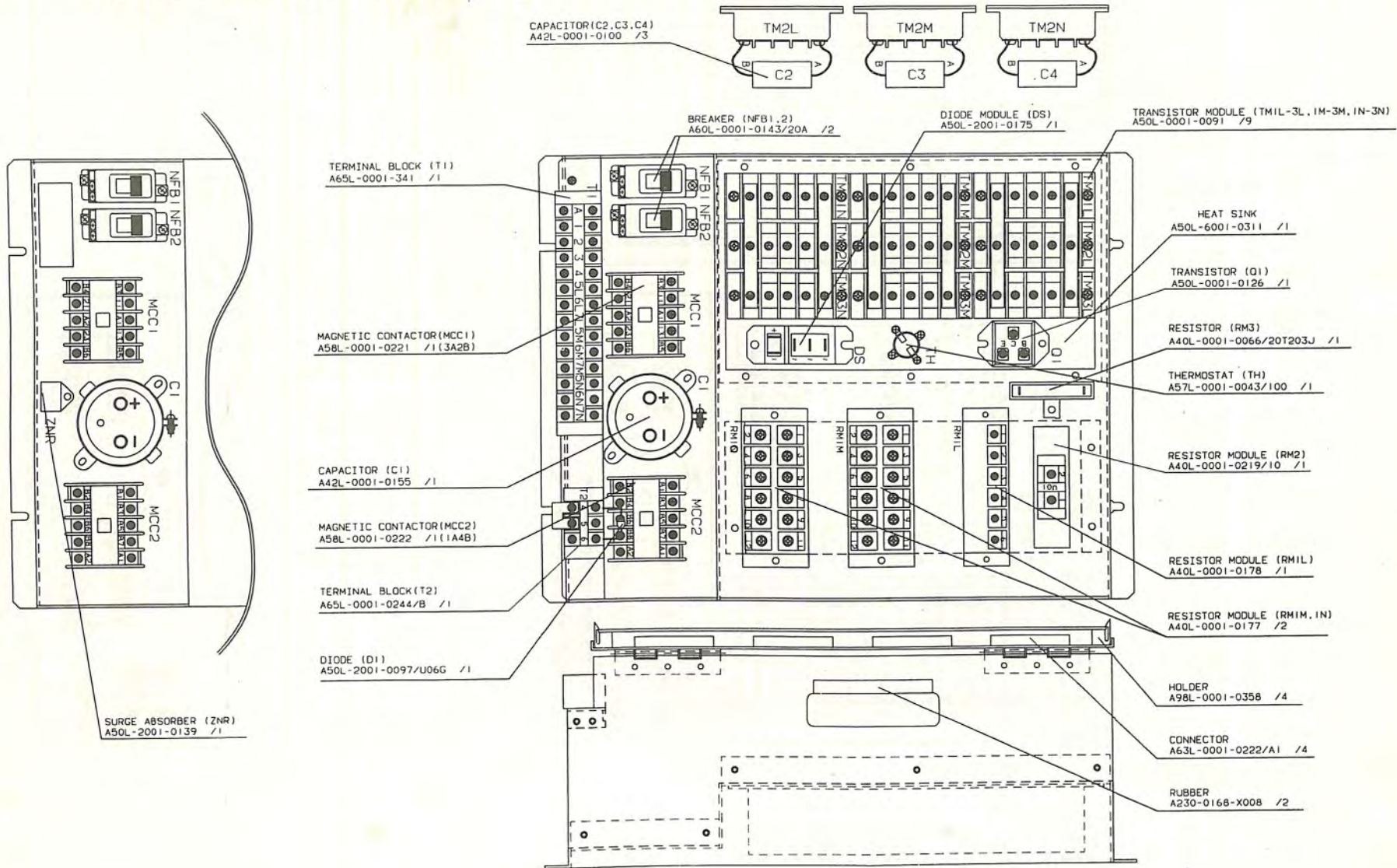

### 5.4 Model 10, Model 10 and Model 10 (A06B-6050-H404)

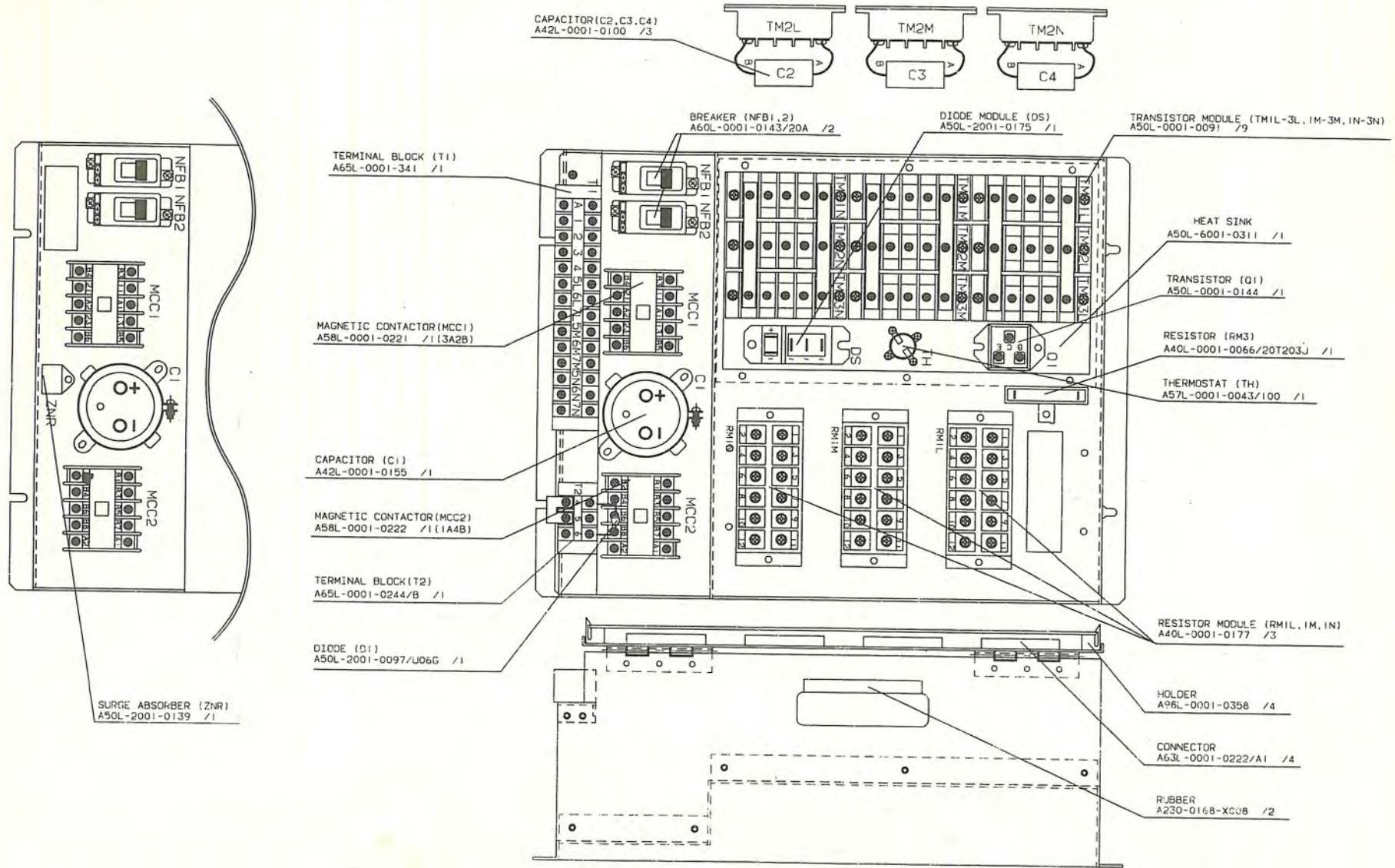

APPENDIX

## APPENDIX 1

### 1. REVERSE CONNECTION

#### 1.1 Connection and Rotational Direction

For AC servo unit there are connection cables of power supply, feedback signals and motor power.

There are standard connection and reverse connection for the feedback signal cable and motor power cable according to the rotational direction which follows the feed command from the control unit.

The rotational direction corresponding to the (+) feed command

Standard connection  
(+) Command

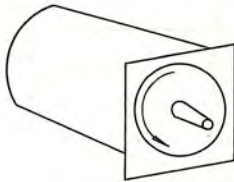

Reverse connection  
(+) Command

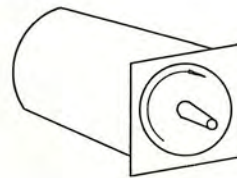

To make reverse connection, next procedure should be taken.

#### 1.2 Method

- (1) For Model 2-0 - 30R

Change the connection of connector mounted on velocity control unit side of feedback signal cable K6 (between motor and CN5).

- ① Signals PCA and PCB should be replaced each other in cable K6.
- ② Signals \*PCA and \*PCB should be replaced each other in cable K6.
- ③ Signals CW and OV (terminal 1 or 2 or 3) should be connected.

Note 1. Connection of motor power line is not changed.

Note 2. This method can apply to velocity edition C or after of velocity control unit PCB (A20B-1000-0560).

The method in item (2) apply to the edition A and B of PCB.

Note 3. This method can apply to AC SERVO UNIT for 2 axes control and AC SERVO UNIT for 3 axes control. Reconstruct cable K6 for axis to be reverse connection according to above changing.

Detail of connection of cable K6 in reverse connection.

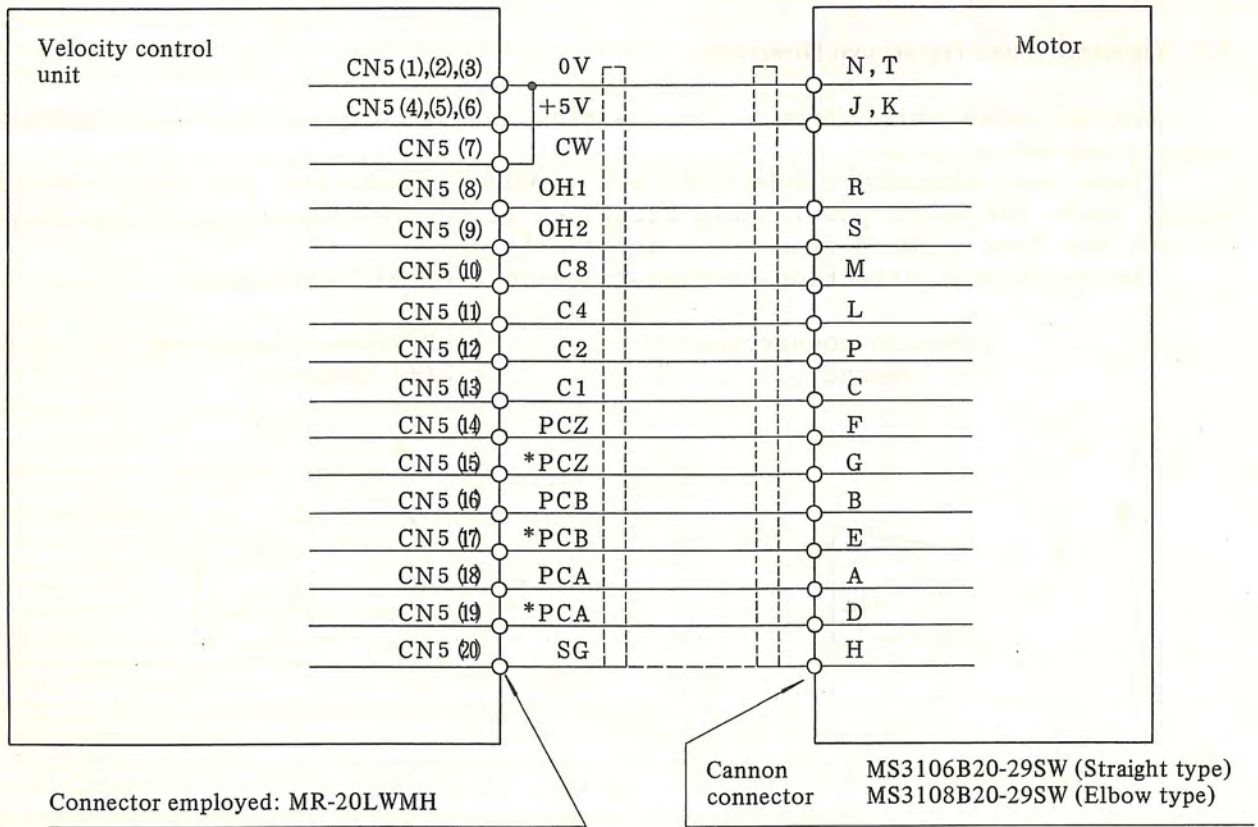

(2) For Model 4-0, 3-0

Change the connection of connector mounted on velocity control unit side of cable K1 and K7 between NC and velocity control unit.

- ① Signal PCA and PCB should be replaced each other in cable K7.
- ② Signal \*PCA and \*PCB should be replaced each other in cable K7.
- ③ Signal VCMD and EC should be replaced each other in cable K1.

Note 1. Connection of motor power line is not changed.

Detail of connection of cable K7 in reverse connection.

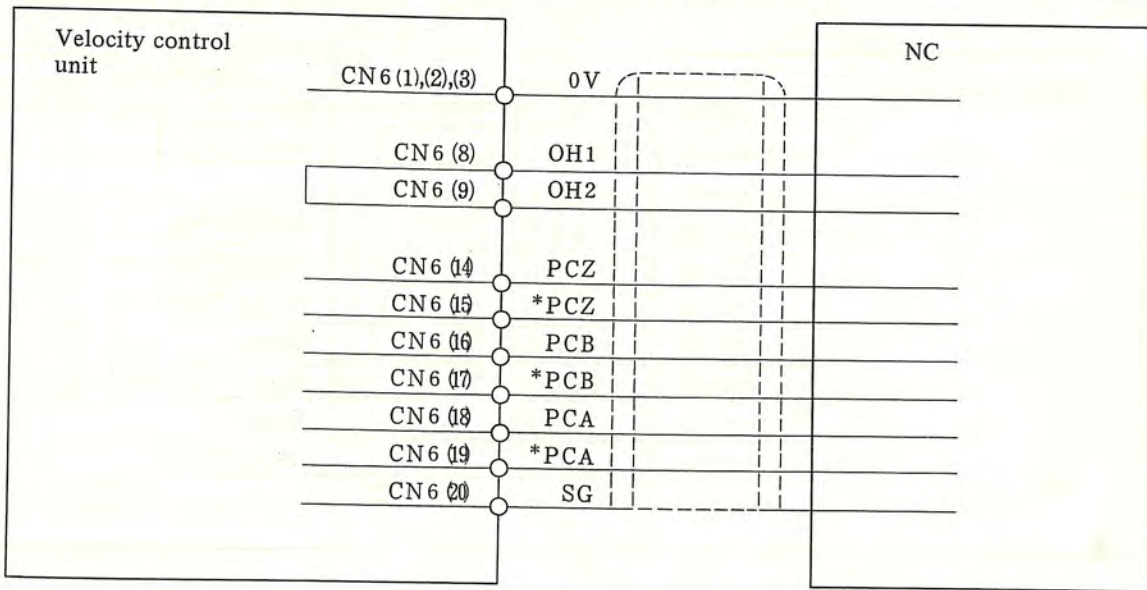

Detail of connection of cable K7 in reverse connection.

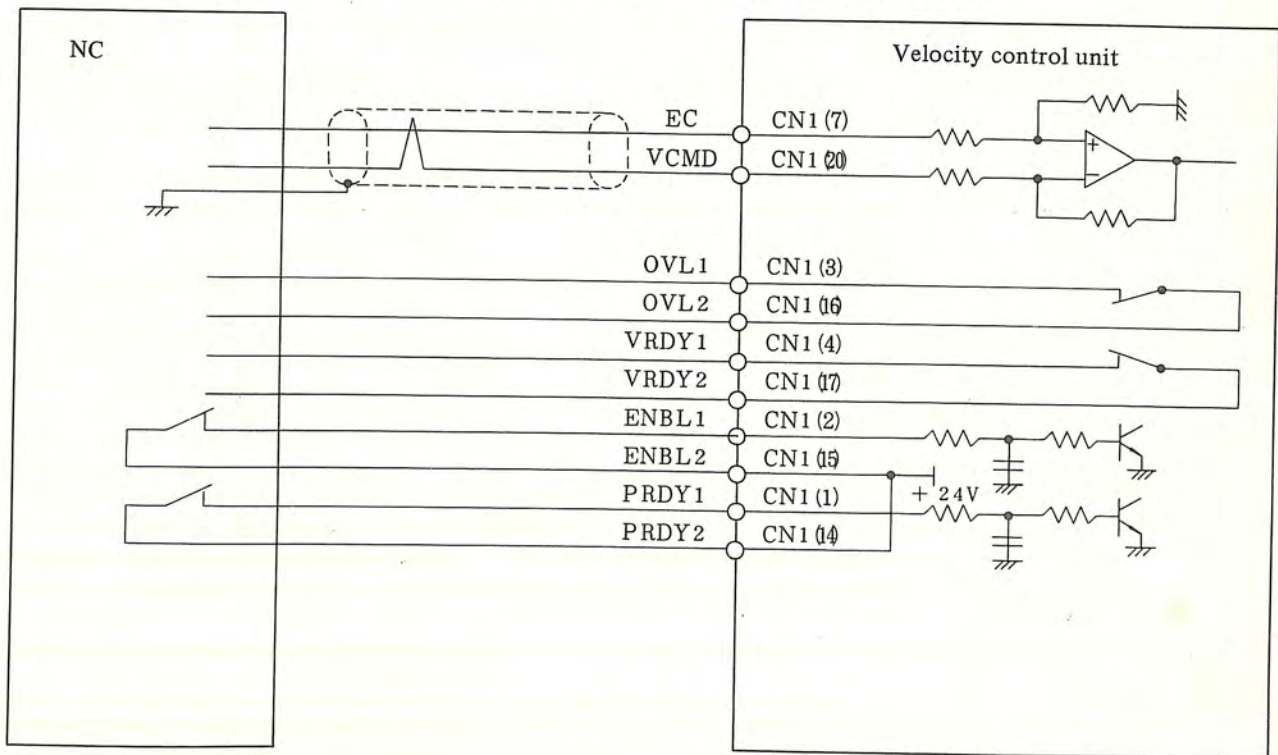

(3) For Model 5-0

Change the connection of connector mounted on velocity control unit side of feedback signal cable K6 (between motor and CN5).

- ① Signal PCA and PCB should be replaced each other in cable K6.
- ② Signal CW and 0V (terminal 1 or 2 or 3) should be connected.

Note 1: Connection of motor power line is not changed.

Detail of connection of cable K6 in reverse connection.

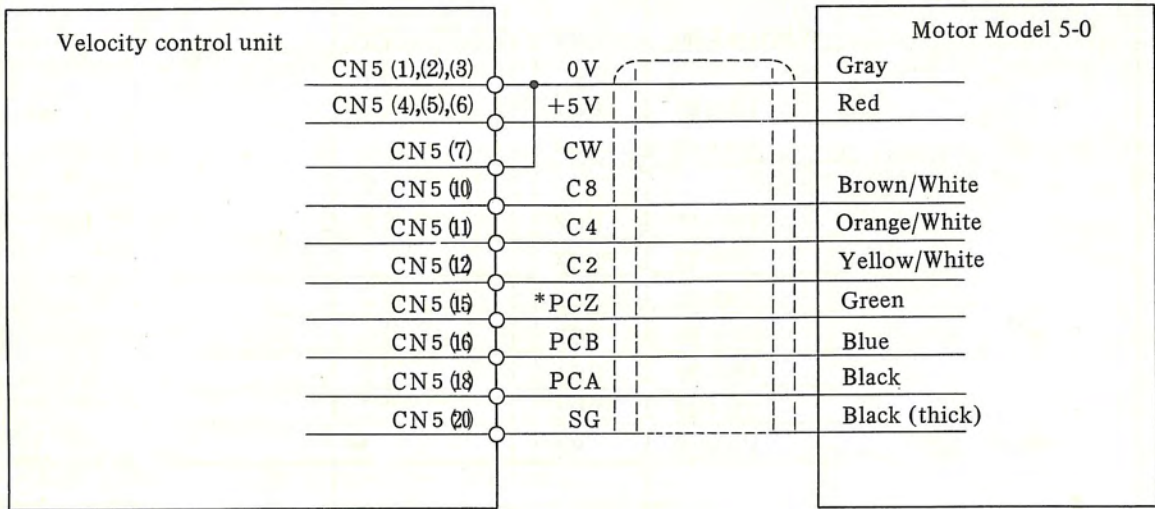

## APPENDIX 2

### 1. AC SERVO MOTOR MAINTENANCE

#### 1.1 Outline

As a rule, AC servo motor is free from periodic maintenance because wearing parts are not included. But AC servo motor contains precise detector, so false operation or damage in transit might cause failure or trouble. It is recommended to check the motor referring to this manual at every chance.

#### 1.2 Acceptance and Storage

Immediately upon receipt of servo motor, check the following items.

- o Whether servo motor is exactly the specified one (check the type, detector type).
- o Whether there is any mechanical damage sustained in transit or not.
- o Whether the rotating part can be normally turned by hand.
- o In the case of the motor with brake, whether the brake is normal.
- o Whether there is any loosened screw or play.

Every servo motor undergoes strict inspection before shipment, therefore any special receipt inspection may not be required as a rule. If the receipt inspection is particularly needed, however, it is advisable to refer to the specifications regarding the wiring of servo motor and detector, current, and voltage so as to make the inspection without any mistake. Don't leave the received servo motor outdoors, but preserve it indoors. Avoid storing it in the place with an extremely high or low humidity, a radical change of temperature, and dust.

#### 1.3 Mounting

Note the following points when mounting the servo motor.

- (1) The water-proof structure of servo motor is not so strict. If cutting oil, lubricating oil, etc. penetrate into the inside of the motor, these may cause poor insulation, short-circuit of the coil. Therefore, due care should be taken so that the motor body will be kept away from such liquids as cutting oil and so on.
- (2) When mounting the servo motor on the gear box where liquid lubrication is performed, if the lip of the oil seal is always exposed to oil, there is a possibility that the oil may penetrate little by little into the inside of the motor in the course of a long time. Therefore the height of the oil level must be lower than the oil seal lip. When the servo motor is mounted with the output shaft upward, mount another oil seal at machine side so as to make the structure where the oil which passed through the first oil seal can directly flow outside.  
The oil seal used for the respective servo motors are listed in the following.



Motor model	Oil seal specification
1-0, 2-0	AB0598E0 (SB type)
0, 5	AB1314F0 ( " )
10, 20M, 20, 30, 30R	AB2057G0 ( " )

The oil seals used for the servo motors are the products of JAPAN OIL SEAL INDUSTRY Co., Ltd.

- (3) The servo motor is coupled with the load through the direct coupling, gears, timing belt or such. In any case the force exerted on the motor shaft must not exceed the values shown in the following table, therefore due care should be taken for the operating condition, mounting method, and mounting accuracy.

Motor model	Permissible radial load
1-0, 2-0	25 kg
0, 5	75 kg
10, 20M, 20, 30, 30R	450 kg

- o The values of permissible radial loads are the ones when the load is imposed on the end of the shaft.

The values in this table indicate the maximum permissible loads which are the sum of the constant force always exerted on the shaft owing to the mounting method (e.g., the force given by the tension of the belt when the belt coupling is used) and the force generated by the load torque (e.g., the force transmitted from the gear face).

- o As a rule, axial load to the shaft should be avoided. Servo motor contains precise detectors, so excess axial shock may give damage to detectors.

- (4) Make the wiring between the servo motor and the control circuit without any mistake, just as specified in the specifications. (See the connection diagram of the machine.) A mistake made in the wiring may cause runaway or abnormal oscillation and may give damage to the motor or the machine. When the wiring is completed, measure the insulation between the power line and the motor frame before turning on the power. The measurement should be made with a 500V megger. Further, check the insulation between the signal lines and the motor frame with a multi-tester. Be sure not to use a megger especially for measuring the insulation of the signal lines for the pulse coder.

## 1.4 Replacement of Pulse Coder

### (1) Abstract

This section is described about the way of replacing pulse coders assuming the case of urgent field troubles due to pulse coders defect, and the way of checking the phase-relationship between AC servo motor and pulse coder. So, if possible, please re-check the phase-relationship.

### (2) The way of replacing pulse coder

The method written here is applicable to AC servo motor model 0, 5, 10, 20M, 20, 30 and 30R. It is impossible to remove pulse coder from other motor models (2-0, 1-0, 3-0, 4-0), because pulse coder itself is directly assembled on to the motor shaft for those type.

#### a. Remove defective pulse coder. (see Fig. 1)

- ① remove rubber cap.
- ② unfasten bolt 1.
- ③ unfasten bolt 2.
- ④ remove pulse coder (+attachments) from the motor shaft.

#### b. Mount new (good) pulse coder.

- ① mount pulse coder (+attachments) on the motor shaft. Notice that both a tooth (of coupling) and a groove (of pulsecoder) are just fitted together. Care should be taken, for fitting length is short.
- ② connect both shaft by bolt 1.
- ③ adjust marking-off line between attachments of pulse coder and motor housing.
- ④ fasten bolt 2.

### (3) The way of checking the phase-relationship

The method written here is applicable to all models of FANUC AC servo motors.

- ① connect V & W of motor power line. (see Fig. 2)
- ② excite motor at rated DC current from U to V & W. (U: +, V & W: -)
- ③ supply DC 5V to the pulse coder, and check signals of C1 - C8. Correct pattern is as follows.

	C1	C2	C4	C8	
	1	1	1	1	
or	1	1	1	0	(1: HI, 0: LOW)

\* change position of C8 is accurate.

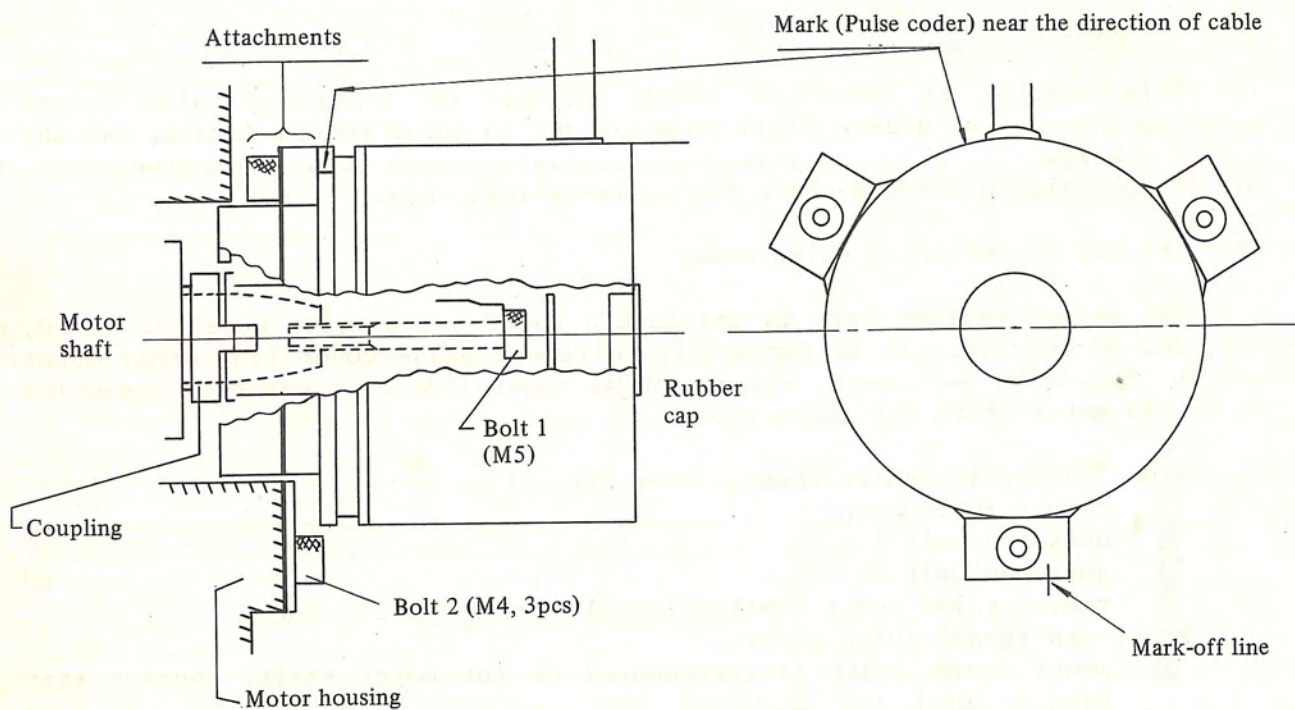

Fig. 1

\* RATED DC CURRENT AT THE CHECK OF PHASE-RELATIONSHIP IS AS FOLLOWS.

MOTOR MODEL	3-0, 4-0	1-0, 2-0	0, 5	10	20, 30	30R
	1.2A	4A	9A	15A	30A	40A

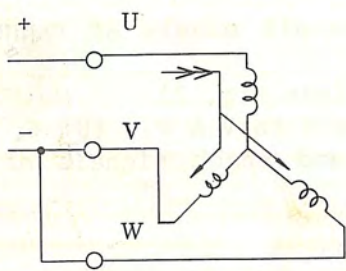

Fig. 2

## 2. COMPENSATING CIRCUIT SETTING FOR AC SERVO UNIT

1) AC servo unit (for one axes) 2 - 0 to 30R

Setting pin	Standard setting					Description
		0 5	10	20 30	30 R	
S21	x	x	x	x	x	High-frequency gain
S22	x	x	x	x	x	High-frequency gain
S23	o	o	x	x	x	VCMD gain setting (7V/1000 rpm, 7V/2000 rpm)
S24	o	o	o	o	o	F/V circuit filter setting
S25	o	o	o	o	o	High-frequency gain
S26	x	x	x	x	x	Low-band gain
S27	x	x	x	x	x	High-frequency gain
S28	x	x	x	x	x	Low-band gain

Short-circuit is marked with a circle.

Expanation      S21: Should it be short-circuited, the high-band gain decreases. Effective when oscillation is generated in the high band (200 to 400 Hz)

                  S22: Be sure it is in the open state.

                  S23: 7V/1000 rpm is set in the open state.  
                  7V/2000 rpm is set in the short-circuit.

                  S24: Be sure it is short-circuited.

                  S25: Should it be open, high-band gain increases.

                  S26: Should it be short-circuited, the low-band gain decreases. Effective in a full-close circuit, or when inertia is large.

                  S27: Should it be open, the high-band gain increases.

                  S28: Should it be short-circuited, the low-band gain decreases. Effective when inertia is large.

\* Whenever the setting of a compensating circuit is changed according to this table, please make contact with our service office.

2) AC servo unit (for two axes)

Setting pin	Standard setting		Description
	1-0 2-0	0 5	
S22L,M	o	o	Gain switching
S23L,M	o	o	VCMD gain setting (7V/1000 rpm, 7V/2000 rpm)
S24L,M	o	o	F/V circuit filter setting
S25L,M	x	x	High-frequency gain
S26L,M	x	x	Low-band gain
S27L,M	o	o	High-frequency gain (Note 1)
S28L,M	x	x	Low-band gain

Short-circuit is marked with a circle.

Note) The open state for S27L,M is standard setting since A20B-1001-0470/05B edition.

Explanation

S22L,M: The open state double the total gain.  
S23L,M: 7V/1000 rpm is set in the open state.  
7V/2000 rpm is set in the short-circuit.  
S24L,M: Be sure it is short-circuited.  
S25L,M: Should it be short-circuited, the gain decreases. Effective when oscillation is generated in the high-band (200 to 400 Hz)  
S26L,M: Should it be short-circuited, the low-band gain decreases. Effective in a full-closed circuit, or when inertia is large.  
S27L,M: Should it be open, the high-band gain increases.  
S28L,M: Should it be short-circuited, the low-band gain decreases. Effective when inertia is large.

\* Whenever the setting of a compensating circuit is changed according to this table, please make contact with our service offices.

3) AC servo unit (for three axes)

Setting pin	Standard setting		Description
	0/5	10	
S22L,M,N	o	×	Gain switching
S23L,M,N	o	×	VCMD gain setting (7V/1000 rpm, 7V/2000 rpm)
S24L,M,N	o	o	F/V circuit filter setting
S25L,M,N	×	×	High-frequency gain
S26L,M,N	×	×	Low-band gain
S27L,M,N	×	×	High-frequency gain
S28L,M,N	×	×	Low-band gain

Short-circuit is marked with a circle

Explanation

S22L,M,N: The open state double the total gain.

S23L,M,N: 7V/1000 rpm is set in the open state.  
7V/2000 rpm is set in the short-circuit.

S24L,M,N: Be sure it is short-circuited.

S25L,M,N: Should it be short-circuited, the high-band gain decreases. Effective when oscillation is generated in the high band (200 to 400 Hz)

S26L,M,N: Should it be short-circuited, the low-band gain decreases. Effective in a full-closed circuit, or when inertia is large.

S27L,M,N: Should it be open, the high-band gain increases.

S28L,M,N: Should it be short-circuited, the low-band gain decreases. Effective when inertia is large.

\* Whenever the setting of a compensating circuit is changed according to this table, please make contact with our service offices.

**Revision Record**  
**FANUC AC SERVO UNIT MAINTENANCE MANUAL (B-54765E)**

02	Jun., '86	<ul style="list-style-type: none"> <li>• Adding of description for 2 axes control servo unit.</li> <li>• Adding of description for 3 axes control servo unit.</li> </ul>			
01	Dec., '83	_____			
<b>Edition</b>	<b>Date</b>	<b>Contents</b>	<b>Edition</b>	<b>Date</b>	<b>Contents</b>